

3 to 5 Serial Cell Li-Ion or Li-Polymer Battery Protection IC

NO.EA-322-240531

OUTLINE

The R5436T is an overcharge, overdischarge and overcurrent protection IC for Li-ion or Li-polymer secondary battery. Overcharge, Overdischarge, Charge Overcurrent and Discharge Overcurrent for 3 to 5 serial cells can be detected. By cascade connection using the R5436T, it is also possible to protect 6-serial or more cells rechargeable battery pack. The R5436T provides a cell-balancing function to equalize imbalance between cells, and it provides an open-wire detection to detect a broken wire between a battery and the circuit board. The open-wire detection is optionally selectable.

FEATURES

- High Voltage Tolerant Process
 - Absolute Maximum Ratings30 V
- Low Supply Current
 - Normal operation with using 5 cellsTyp. 12.0 μ A
 - StandbyTyp. 6.0 μ A
- High-accuracy Voltage Detection
 - Overcharge detection voltage ($V_{DET1n}^{(1)}$)3.6 V to 4.5 V (in 5 mV steps)
 - Overcharge detection voltage accuracy ± 0.025 V ($T_a = 25^\circ\text{C}$)
 - Overdischarge detection voltage ($V_{DET2n}^{(1)}$)2.0 V to 3.2 V (in 5 mV steps)
 - Overdischarge detection voltage accuracy $\pm 2.5\%$
 - Discharge overcurrent detection voltage1 ($V_{DET31}^{(2)}$)0.05 V to 0.25 V (in 10 mV steps)
 - Discharge overcurrent detection voltage1 accuracy ± 15 mV($V_{DET31} \leq 0.15\text{V}$) / ± 20 mV($V_{DET31} > 0.15\text{V}$)
 - Discharge overcurrent detection voltage2 (V_{DET32}) $V_{DET31} \times 3$
 - Discharge overcurrent detection voltage2 accuracy ± 25 mV($V_{DET31} \leq 0.10\text{V}$) / ± 50 mV($V_{DET31} > 0.10\text{V}$)
 - Short-circuit detection voltage⁽³⁾0.25 V to 1.0 V (in 20 mV steps)
 - Charge overcurrent detection voltage-0.05 V / -0.1 V / -0.2 V
 - Charge overcurrent detection voltage accuracy (V_{DET4}) ± 15 mV ($V_{DET4} = -0.05$ V / -0.1 V) / ± 30 mV ($V_{DET4} = -0.2$ V)
 - Overcharge release voltage $V_{DET1n} - 0.1\text{V}$ to $V_{DET1n} - 0.4\text{V}$ (in 10mV steps)
 - Overdischarge release voltage $V_{DET2n} + 0.0\text{V}$ to $V_{DET2n} + 0.7\text{V}$ (in 50mV steps)
-provided, max.value is 3.2V.
 - Cell-balancing detection voltage ($V_{CBDn}^{(1)}$)3.45V to 4.45V (in 5 mV steps)
 - Cell-balancing release voltage $V_{CBDn} - 0.0\text{V}$ to $V_{CBDn} - 0.4\text{V}$ (in 10mV steps)
- Each Detection Delay Time
 - Overcharge detection delay time1.0 sec
 - Overdischarge detection delay time settable by external capacitor
 - Discharge overcurrent detection delay time 1/2 settable by external capacitor
 - Charge overcurrent detection delay time8 ms
 - Short-circuit detection delay time330 μ s

⁽¹⁾ V_{DET1n}, V_{CBDn} : n = 1, 2, 3, 4, 5

⁽²⁾ Set to meet the following equation: $(3 \times V_{DET31} + 0.05 < 0.8 \times V_{SHORT})$.

⁽³⁾ V_{DET32} is not detected when V_{DET32} is higher than V_{SHORT} .

- 0 V Battery Charging Available
- Overcharge Release Voltage Condition Voltage release type
- Overdischarge Release Voltage Condition Latch type / Voltage release type
- 3 to 5 Cells Selectable Battery Protection
- Delay Time Shortening Function
- Selectable Broken-wire Detection Typ.1.25 s
- External NTC temperature protection function
- Package TSSOP-28 (JEDEC: 173 MIL)

APPLICATIONS

- Li-ion/Li-polymer battery protection for electric tool and electric bicycle, etc.

SELECTION GUIDE

In the R5436T, the set voltage, the delay time, and the optional function can be designated.

Selection Guide

Product Name	Package	Quantity per Reel	Pb Free	Halogen Free
R5436Txxx* $\$$ -E2-FF	TSSOP-28	3,000 pcs	Yes	Yes

xxx: Specify a combination of the following set output voltages. Refer to *Product Code List* for details.

$V_{DET1n}^{(1)}$: 3.6 V to 4.5 V in 5 mV steps

$V_{REL1n}^{(1)}$: $V_{DET1n} - 0.1$ V to $V_{DET1n} - 0.4$ V in 10 mV steps (Min.3.45 V)

$V_{CBDn}^{(1)}$: 3.45 V to 4.45 V in 5mV steps

$V_{CBRn}^{(1)}$: $V_{CBDn} - 0.0$ V to $V_{CBDn} - 0.4$ V in 10 mV steps (Min.3.45 V)

$V_{DET2n}^{(1)}$: 2.0 V to 3.2 V in 5 mV steps

$V_{REL2n}^{(1)}$: $V_{DET2n} + 0.0$ V to $V_{DET2n} + 0.7$ V in 50 mV steps (Max. 3.2 V)

V_{DET31} : 0.05 V to 0.25 V in 10 mV steps

V_{DET32} : Fixed to three times V_{DET31}

V_{SHORT} : 0.25 V to 1.0 V in 20 mV steps

V_{DET4} : -0.05V, -0.1V, or -0.2V

*: Specify a combination of the following each detection delay time.

Code	t_{VDET1} [s]	t_{VDET2} [ms]	t_{VDET31} [ms]	t_{VDET32} [ms]	t_{VDET4} [ms]	t_{SHORT} [μ s]
B	1.0	$3.60 \times C_{CT1}$ [nF]	$3.00 \times C_{CT2}$ [nF]	$t_{VDET31}/6$	8	330

$\$$: Specify a combination of the optional functions.

Code	Overcharge Released Type	Overdischarge Released Type	0 V Battery Charging	Open-wire Detection
A	Voltage Release	Latch	Available	Available
B	Voltage Release	Voltage Release	Available	Unavailable

⁽¹⁾ V_{DET1n} , V_{REL1n} , V_{CBDn} , V_{CBRn} , V_{DET2n} , V_{REL2n} : n = 1, 2, 3, 4, 5

Product Code List

The product code is determined by the combination of the set voltages (Overcharge Detection Voltage: V_{DET1n} , Overcharge Release Voltage: V_{REL1n} , Cell-balancing Detection Voltage: V_{CBDn} , Cell-balancing Release Voltage: V_{CBRn} , Overdischarge Detection Voltage: V_{DET2n} , Overdischarge Release Voltage: V_{REL2n} , Discharge Overcurrent Detection Voltage 1/2: V_{DET31} / V_{DET32} , Short-circuit Detection Voltage: V_{SHORT} , Charge Overcurrent Detection Voltage: V_{DET4}), the delay time code, and the optional function code.

Product Name (Product Code)	Set Voltage [V]									
	V_{DET1n}	V_{REL1n}	V_{CBDn}	V_{CBRn}	V_{DET2n}	V_{REL2n}	V_{DET31}	V_{DET32}	V_{SHORT}	V_{DET4}
R5436T401BA	4.225	4.175	4.125	4.125	3.000	3.200	0.100	0.300	0.700	-0.100
R5436T502BA	4.250	4.100	4.200	4.190	2.500	3.000	0.100	0.300	0.420	-0.050
R5436T502BB										
R5436T503BA	4.250	4.150	4.200	4.190	2.800	3.200	0.100	0.300	0.420	-0.050
R5436T503BB										
R5436T504BA	4.280	4.220	4.180	4.170	2.500	3.000	0.100	0.300	0.420	-0.050
R5436T504BB										
R5436T505BA	3.800	3.500	3.550	3.540	2.200	2.500	0.080	0.240	0.300	-0.050
R5436T505BB										
R5436T506BA	3.800	3.600	3.600	3.550	2.750	3.000	0.150	0.450	0.450	-0.050
R5436T506BB										
R5436T507BA	4.200	4.170	4.160	4.150	2.800	3.000	0.100	0.300	0.420	-0.050
R5436T507BB										
R5436T508BA	3.650	3.450	3.550	3.530	2.000	2.500	0.100	0.300	0.420	-0.050
R5436T508BB										
R5436T509BA	4.350	4.150	4.300	4.290	2.700	3.000	0.100	0.300	0.420	-0.050
R5436T510BA	4.250	4.100	4.225	4.215	2.500	3.000	0.100	0.300	0.420	-0.050
R5436T511BA	4.250	4.150	4.200	4.190	2.750	3.000	0.080	0.240	0.300	-0.050
R5436T511BB										
R5436T512BB	4.250	4.100	4.200	4.190	2.500	3.000	0.080	0.240	0.250	-0.050
R5436T513BB	4.400	4.250	4.350	4.340	2.700	3.000	0.100	0.300	0.420	-0.050
R5436T514BB	4.250	4.150	4.200	4.190	2.150	2.250	0.250	0.750	1.000	-0.200
R5436T515BB	3.650	3.450	3.550	3.530	2.300	3.000	0.100	0.300	0.420	-0.050
R5436T516BA	4.180	4.150	4.160	4.150	2.750	2.850	0.100	0.300	0.420	-0.050
R5436T517BB	4.180	4.150	4.145	4.135	2.800	2.900	0.050	0.150	0.250	-0.050
R5436T518BB	3.650	3.500	3.450	3.440	2.300	2.500	0.050	0.150	0.250	-0.050
R5436T519BB	3.650	3.530	3.500	3.490	2.500	2.750	0.050	0.150	0.250	-0.050
R5436T520BB	4.200	4.000	4.160	4.150	2.900	3.200	0.100	0.300	0.420	-0.100

Product Name (Product Code)	Set Voltage [V]									
	V _{DET1n}	V _{REL1n}	V _{CBDn}	V _{CBRn}	V _{DET2n}	V _{REL2n}	V _{DET31}	V _{DET32}	V _{SHORT}	V _{DET4}
R5436T 521 BB	4.125	4.025	4.075	4.065	2.600	3.100	0.100	0.300	0.420	-0.100
R5436T 522 BB	4.200	4.170	4.160	4.150	2.800	3.000	0.050	0.150	0.250	-0.050
R5436T 523 BB	3.900	3.800	3.600	3.550	2.000	2.500	0.100	0.300	0.420	-0.100
R5436T 524 BB	3.750	3.550	3.550	3.450	2.000	2.300	0.050	0.150	0.250	-0.050

Please contact our sales representatives if required a product code other than the above combinations.

BLOCK DIAGRAM

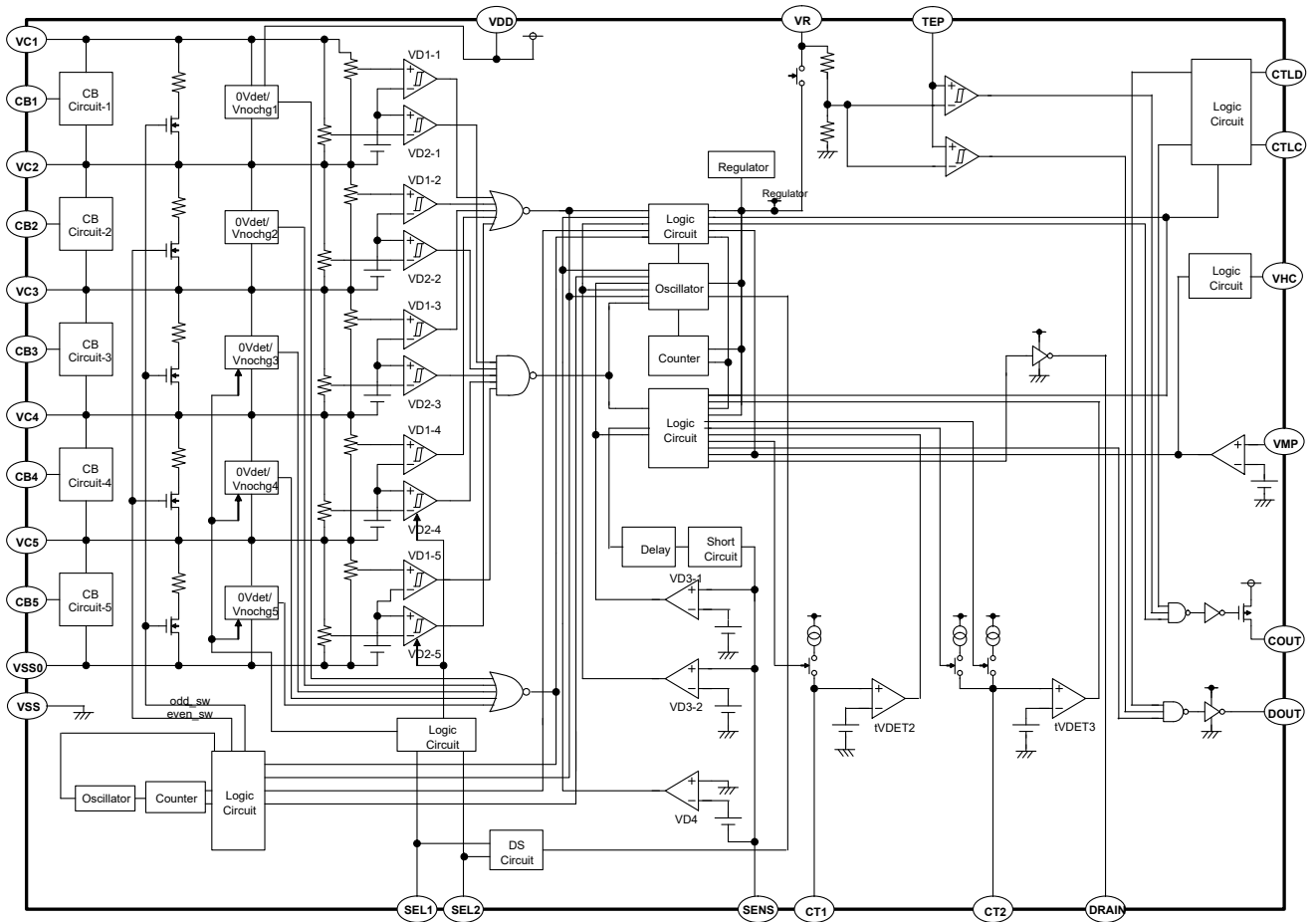

R5436T Block Diagram

PIN DESCRIPTIONS

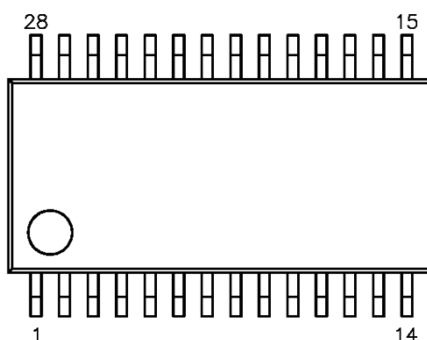

R5436T (TSSOP-28) Pin Configuration

R5436T Pin Description

Pin No.	Symbol	Description
1	CTLC	COUT control pin
2	CTLD	DOUT control pin
3	COUT	Overcharge detection output pin, Pch. open-drain output
4	VMP	Charger negative input pin
5	DRAIN	FET's gate connection pin for discharge overcurrent release voltage
6	DOUT	Overdischarge detection output pin, CMOS output
7	VHC	Transmission pin for VMP input signal
8	SENS	Current sense pin
9	VR	Internal VR output pin
10	TEP	Temperature protection input pin
11	VSS	Ground pin for the IC
12	CT1	Capacitor (C_{CT1}) connection pin for setting t_{VDET2}
13	CT2	Capacitor (C_{CT2}) connection pin for setting t_{VDET3}
14	SEL1	3- / 4- / 5-cell selectable pins
15	SEL2	
16	VSS0	Negative terminal for CELL5
17	CB5	Cell balance control pin for CELL5
18	VC5	Positive terminal for CELL5
19	CB4	Cell balance control pin for CELL4
20	VC4	Positive terminal for CELL4
21	CB3	Cell balance control pin for CELL3
22	VC3	Positive terminal for CELL3
23	CB2	Cell balance control pin for CELL2
24	VC2	Positive terminal for CELL2
25	CB1	Cell balance control pin for CELL1
26	NC	No Connection
27	VC1	Positive terminal for CELL1
28	VDD	VDD pin

ABSOLUTE MAXIMUM RATINGS(Ta = 25°C, V_{SS} = 0 V)

Symbol	Parameter	Rating	Unit
V _{DD}	Supply voltage	-0.3 to 30	V
V _{C1}	CELL1 positive input pin voltage	V _{C2} -0.3 to V _{C2} +6.5	V
V _{C2}	CELL2 positive input pin voltage	V _{C3} -0.3 to V _{C3} +6.5	V
V _{C3}	CELL3 positive input pin voltage	V _{C4} -0.3 to V _{C4} +6.5	V
V _{C4}	CELL4 positive input pin voltage	V _{C5} -0.3 to V _{C5} +6.5	V
V _{C5}	CELL5 positive input pin voltage	V _{SS0} -0.3 to V _{SS0} +6.5	V
V _{SS0}	CELL5 negative input pin voltage	-0.3 to V _{C5} +0.3	V
V _{MP}	Charger negative input pin voltage	V _{DD} -30 to V _{DD} +0.3	V
V _{SEL1}	SEL1 pin input voltage	-0.3 to V _{DD} +0.3	V
V _{SEL2}	SEL2 pin input voltage	-0.3 to V _{DD} +0.3	V
V _{CTLC}	COUT control pin voltage	-0.3 to V _{DD} +25 < 48	V
V _{CTLD}	DOUT control pin voltage	-0.3 to V _{DD} +25 < 48	V
V _{SENS}	Current sense pin voltage	V _{VR} -6.5 to V _{VR} +0.3	V
V _{CT1}	Delay time setting 1 pin voltage	-0.3 to V _{VR} +0.3	V
V _{CT2}	Delay time setting 2 pin voltage	-0.3 to V _{VR} +0.3	V
V _{TEP}	Temperature protection input pin voltage	-0.3 to V _{VR} +0.3	V
V _{COOUT}	COUT pin output voltage	V _{DD} -30 to V _{DD} +0.3	V
V _{DOOUT}	DOUT pin output voltage	-0.3 to V _{OH2} +0.3	V
V _{DRAIN}	DRAIN pin output voltage	-0.3 to V _{OH3} +0.3	V
V _{CB1}	CB1 pin output voltage	V _{C2} -0.3 to V _{C2} +6.5	V
V _{CB2}	CB2 pin output voltage	V _{C3} -0.3 to V _{C3} +6.5	V
V _{CB3}	CB3 pin output voltage	V _{C4} -0.3 to V _{C4} +6.5	V
V _{CB4}	CB4 pin output voltage	V _{C5} -0.3 to V _{C5} +6.5	V
V _{CB5}	CB5 pin output voltage	-0.3 to 6.5	V
V _{VHC}	VHC pin output voltage	V _{DD} -3 to V _{DD} +5	V
V _{VR}	VR pin output voltage	-0.3 to V _{VR} +0.3	V
P _D	Power Dissipation	Refer to Appendix "Power Dissipation".	
T _j	Junction Temperature Range	-40 to 125	°C
T _{stg}	Storage Temperature Range	-55 to 125	°C

ABSOLUTE MAXIMUM RATINGS

Electronic and mechanical stress momentarily exceeded absolute maximum ratings may cause permanent damage and may degrade the lifetime and safety for both device and system using the device in the field. The functional operation at or over these absolute maximum ratings is not assured.

RECOMMENDED OPERATING CONDITION

Symbol	Parameter	Rating	Unit
V _{DD}	Operating Input Voltage	2.5 to 25	V
T _a	Operating Temperature Range	-40 to 85	°C

RECOMMENDED OPERATING CONDITIONS

All of electronic equipment should be designed that the mounted semiconductor devices operate within the recommended operating conditions. The semiconductor devices cannot operate normally over the recommended operating conditions, even if they are used over such conditions by momentary electronic noise or surge. And the semiconductor devices may receive serious damage when they continue to operate over the recommended operating conditions.

ELECTRICAL CHARACTERISTICS

$V_{CELLn} = CELLn$ (EX. V_{CELL1} is a voltage difference between VC1 and VC2)

$n = 1, 2, 3, 4, 5$, unless otherwise noted.

R5436TxxxBA / R5436TxxxBB Electrical Characteristics

($T_a = 25^\circ\text{C}$)

Symbol	Parameter	Conditions	Min.	Typ.	Max.	Unit	Circuit (1)	
V_{DET1n}	CELLn overcharge detection voltage	At rising edge detection of supply voltage	V_{DET1n} -0.025V	V_{DET1n}	V_{DET1n} +0.025V	V	A	
V_{REL1n}	CELLn overcharge release voltage	At falling edge detection of supply voltage	V_{REL1n} -0.050V	V_{REL1n}	V_{REL1n} +0.050V	V	A	
t_{VDET1}	Overcharge detection delay time	$VDD=VC1, V_{CELLn}=3.5V$ (n=2,3,4,5) $V_{CELL1}=3.5V \rightarrow 4.5V$	0.7	1.0	1.3	s	B	
t_{VREL1}	Overcharge release delay time	$VDD=VC1, V_{CELLn}=3.5V$ (n=2,3,4,5) $V_{CELL1}=4.5V \rightarrow 3.0V$	11	16	21	ms	B	
V_{CBDn}	CELLn cell balance detection voltage	At rising edge detection of supply voltage	V_{CBDn} -0.025V	V_{CBDn}	V_{CBDn} +0.025V	V	C	
V_{CBRn}	CELLn cell balance release voltage (2)	At falling edge detection of supply voltage	V_{CBRn} -0.050V	V_{CBRn}	V_{CBRn} +0.050V or V_{CBDn} +0.025V	V	C	
t_{VCBD}	CELLn cell balance detection delay time	$VDD=VC1, V_{CELLn}=3.5V$ (n=2,3,4,5) $V_{CELL1}=3.5V \rightarrow V_{CBDn}$	11	16	21	ms	C	
V_{DET2n}	CELLn overdischarge detection voltage	At falling edge detection of supply voltage	V_{DET2n} $\times 0.975V$	V_{DET2n}	V_{DET2n} $\times 1.025V$	V	D	
V_{REL2n}	CELLn overdischarge release voltage	At rising edge detection of supply voltage	V_{REL2n} $\times 0.975V$	V_{REL2n}	V_{REL2n} $\times 1.025V$	V	D	
I_{CT1}	CT1 charging current	$VDD=VC1, V_{CELLn}=3.5V$ (n=2,3,4,5) $V_{CELL1}=3.5V \rightarrow 1.5V$	350	500	650	nA	E	
V_{DCT1}	CT1 detection voltage	$VDD=VC1, V_{CELLn}=3.5V$ (n=2,3,4,5), $V_{CELL1}=1.5V$	1.44	1.80	2.16	V	F	
t_{VDET2}	Overdischarge detection delay time	$t_{VDET2}=C_{CT1} \times V_{DCT1} / I_{CT1}, C_{CT1}=33nF$	83	119	155	ms	-	
t_{VREL2}	Overdischarge release delay time	$VDD=VC1, V_{CELLn}=3.5V$ (n=2,3,4,5) $V_{CELL1}=1.5V \rightarrow 3.5V$	0.7	1.2	1.7	ms	G	
V_{DET31}	Discharge overcurrent detection voltage 1	$VDD=VC1, V_{CELLn}=3.5V,$ $V_{MP}=4.0V,$ At rising edge detection of SENS pin	$V_{DET31} \leq 0.15V$	V_{DET31} -0.015V	V_{DET31}	V_{DET31} +0.015V	V	H
			$V_{DET31} > 0.15V$	V_{DET31} -0.020V		V_{DET31} +0.020V		
V_{DET32}	Discharge overcurrent detection voltage 2	$VDD=VC1, V_{CELLn}=3.5V,$ $V_{MP}=4.0V,$ At rising edge detection of SENS pin	$V_{DET31} \leq 0.10V$	V_{DET32} -0.025V	V_{DET32}	V_{DET32} +0.025V	V	I
			$V_{DET31} > 0.10V$	V_{DET32} -0.050V		V_{DET32} +0.050V		
V_{REL3}	Discharge overcurrent release voltage	$VDD=VC1, V_{CELLn}=3.5V, SENS=0.0V,$ At falling edge detection of VMP pin	0.8	1.0	1.2	V	H	
I_{CT231}	CT2 charge current 1	$VDD=VC1, V_{CELLn}=3.5V,$ $SENS=V_{SS} \rightarrow 0.4V$	350	500	650	nA	I	

(1) Refer to TEST CIRCUITS for detail information.

(2) Max. value is equal to the lower value of $V_{CBRn}+0.050V$ or $V_{CBDn}+0.025V$.

$V_{CELLn} = CELLn$ (Ex. V_{CELL1} is a voltage difference between VC1 and VC2)
 $n = 1, 2, 3, 4, 5$, unless otherwise noted.

R5436TxxxBA / R5436TxxxBB Electrical Characteristics (Continued)

(Ta = 25°C)

Symbol	Parameter	Conditions	Min.	Typ.	Max.	Unit	Circuit (1)
I_{CT232}	CT2 charge current 2	VDD=VC1, $V_{CELLn}=3.5V$ SENS= $V_{SS} \rightarrow 0.7V$	2.0	3.0	4.0	μA	I
V_{DCT2}	CT2 detection voltage	VDD=VC1, $V_{CELLn}=3.5V$ SENS=0.4V, $V_{MP}=4.0V$	1.20	1.50	1.80	V	J
t_{VDET31}	Discharge overcurrent detection delay time 1	$t_{VDET31} = C_{CT2} \times V_{DCT2} / I_{CT231}$ $C_{CT2}=3.3nF$	6.9	9.9	12.9	ms	-
t_{VDET32}	Discharge overcurrent detection delay time 2	$t_{VDET32} = C_{CT2} \times V_{DCT2} / I_{CT232}$ $C_{CT2}=3.3nF$	1.1	1.65	2.2	ms	-
t_{VREL3}	Discharge overcurrent release delay time	VDD=VC1, $V_{CELLn}=3.5V$, SENS= V_{SS} , $V_{MP}=4.0V \rightarrow V_{SS}$	0.7	1.2	1.7	ms	H
V_{SHORT}	Short-circuit detection voltage	VDD=VC1, $V_{CELLn}=3.5V$, $V_{MP}=4.0V$, At rising edge detection of SENS pin	$V_{SHORT} \times 0.8$	V_{SHORT}	$V_{SHORT} \times 1.2$	V	K
t_{SHORT}	Short-circuit detection delay time	VDD=VC1, $V_{CELLn}=3.5V$, SENS=0.0V \rightarrow 2.0V, $V_{MP}=4.0V$	230	330	430	μs	K
V_{DET4}	Charge overcurrent detection voltage	VDD=VC1, $V_{CELLn}=3.5V$, $V_{MP} = -1.0V$, At falling edge detection of SENS pin	$V_{DET4} \geq -0.1V$ $V_{DET4} < -0.1V$	$V_{DET4} - 0.015V$ $V_{DET4} - 0.030V$	$V_{DET4} + 0.015V$ $V_{DET4} + 0.030V$	V	L
V_{REL4}	Charge overcurrent release voltage	VDD=VC1, $V_{CELLn}=3.5V$ At rising edge detection of VMP pin	0.05	0.1	0.15	V	L
t_{VDET4}	Charge overcurrent detection delay time	VDD=VC1, $V_{CELLn}=3.5V$, SENS=0.0V \rightarrow -1.0V	5	8	11	ms	L
t_{VREL4}	Charge overcurrent release delay time	VDD=VC1, $V_{CELLn}=3.5V$, SENS= V_{SS} , $V_{MP} = -1.0V \rightarrow 1.0V$	0.7	1.2	1.7	ms	L
V_{IH1}	SEL1 pin "High" input voltage	VDD=VC1, $V_{CELLn} = 3.4V$	$V_{DD} - 0.3V$		$V_{DD} + 0.3V$	V	M
V_{IM1}	SEL1 pin "Middle" input voltage	VDD=VC1, $V_{CELLn} = 3.4V$	4.0		$V_{DD}/2 - 0.5V$	V	M
V_{IL1}	SEL1 pin "Low" input voltage	VDD=VC1, $V_{CELLn} = 3.4V$	$V_{SS} - 0.3V$		$V_{SS} + 0.3V$	V	M
V_{IH2}	SEL2 pin "High" input voltage	VDD=VC1, $V_{CELLn} = 3.4V$	$V_{DD} - 0.3V$		$V_{DD} + 0.3V$	V	N
V_{IM2}	SEL2 pin "Middle" input voltage	VDD=VC1, $V_{CELLn} = 3.4V$	4.0		$V_{DD}/2 - 0.5V$	V	N
V_{IL2}	SEL2 pin "Low" input voltage	VDD=VC1, $V_{CELLn} = 3.4V$	$V_{SS} - 0.3V$		$V_{SS} + 0.3V$	V	N
V_{CTLC1H}	CTLC pin "High" threshold voltage 1	VDD=VC1, $V_{CELLn} = 3.4V$	17.5	18.1	18.7	V	O
V_{CTLC2H}	CTLC pin "High" threshold voltage 2	VDD=VC1, $V_{CELLn} = 3.4V$	15.1	16.1	16.6	V	O
V_{CTLD1H}	CTLD pin "High" threshold voltage 1	VDD=VC1, $V_{CELLn} = 3.4V$	17.5	18.1	18.7	V	P
V_{CTLD2H}	CTLD pin "High" threshold voltage 2	VDD=VC1, $V_{CELLn} = 3.4V$	15.1	16.1	16.6	V	P

(1) Refer to TEST CIRCUITS for detail information.

$V_{CELLn} = CELLn$ (Ex. V_{CELL1} is a voltage difference between VC1 and VC2)
 $n = 1, 2, 3, 4, 5$, unless otherwise noted.

R5436TxxxBA / R5436TxxxBB Electrical Characteristics (Continued)

(Ta = 25°C)

Symbol	Item	Conditions	Min.	Typ.	Max.	Unit	Circuit (1)
t _{CTLD1}	CTLD pin input delay time 1 (R5436TxxxBB only)	V _{DD} =V _{C1} , V _{CELLn} = 3.4V CTLD=V _{DD} +0.5V→V _{DD} +1.7V		1.5	6	ms	P
t _{CTLD2}	CTLD pin input delay time 2 (R5436TxxxBB only)	V _{DD} =V _{C1} , V _{CELLn} = 3.4V CTLD=V _{DD} +1.7V→V _{DD} +0.5V		1.5	6	ms	P
V _{OL2}	DOUT pin Nch.ON voltage	I _{OL} =50μA, V _{DD} =V _{C1} , CTLD=V _{DD} V _{CELLn} = 3.4V		0.1	0.5	V	Q
V _{OL3}	DRAIN pin Nch.ON voltage	I _{OL} =50μA, V _{DD} =V _{C1} , V _{CELLn} = 3.4V		0.1	0.5	V	R
V _{OL4}	CB1 pin Nch.ON voltage	I _{OL} =50μA, V _{DD} =V _{C1} , V _{CELLn} = 3.4V		V _{C2} +0.2V	V _{C2} +0.5V	V	S
V _{OL5}	CB2 pin Nch.ON voltage	I _{OL} =50μA, V _{DD} =V _{C1} , V _{CELLn} = 3.4V		V _{C3} +0.2V	V _{C3} +0.5V	V	S
V _{OL6}	CB3 pin Nch.ON voltage	I _{OL} =50μA, V _{DD} =V _{C1} , V _{CELLn} = 3.4V		V _{C4} +0.2V	V _{C4} +0.5V	V	S
V _{OL7}	CB4 pin Nch.ON voltage	I _{OL} =50μA, V _{DD} =V _{C1} , V _{CELLn} = 3.4V		V _{C5} +0.2V	V _{C5} +0.5V	V	S
V _{OL8}	CB5 pin Nch.ON voltage	I _{OL} =50μA, V _{DD} =V _{C1} , V _{CELLn} = 3.4V		0.2V	0.5V	V	S
V _{OH1}	COUT pin Pch.ON voltage	I _{OH} =-50μA, V _{DD} =V _{C1} , CTLC=V _{SS} , V _{CELLn} =3.4V	V _{DD} -0.5V	V _{DD} -0.1V		V	T
V _{VR12}	VR12V output voltage	I _{OH} =-5μA, V _{DD} =V _{C1} , CTLD=V _{SS} , V _{CELLn} = 3.4V, The measured value by pulling current through DOUT pin.	9.5	12	14	V	U
V _{OH2} (2)	DOUT pin Pch.ON voltage	I _{OH} = -50μA, V _{DD} =V _{C1} , CTLD= V _{SS} , V _{CELLn} = 3.2V	V _{VR12} -0.5V	V _{VR12} -0.1V		V	U
V _{OH3} (2)	DRAIN pin Pch.ON voltage	I _{OH} = -50μA, V _{DD} =V _{C1} , V _{CELL} = 3.2V, SENS=VMP=4.0V	V _{VR12} -0.5V	V _{VR12} -0.1V		V	V
V _{OH4}	CB1 pin Pch.ON voltage	I _{OH} = -50μA, V _{DD} =V _{C1} , V _{C1} =4.5V, V _{CELLn} =3.2V (n=2,3,4,5)	V _{C1} -0.5V	V _{C1} -0.3V		V	W
V _{OH5}	CB2 pin Pch.ON voltage	I _{OH} = -50μA, V _{DD} =V _{C1} , V _{C2} =4.5V, V _{CELLn} =3.2V (n=1,3,4,5)	V _{C2} -0.5V	V _{C2} -0.3V		V	W
V _{OH6}	CB3 pin Pch.ON voltage	I _{OH} = -50μA, V _{DD} =V _{C1} , V _{C3} =4.5V, V _{CELLn} =3.2V (n=1,2,4,5)	V _{C3} -0.5V	V _{C3} -0.3V		V	W
V _{OH7}	CB4 pin Pch.ON voltage	I _{OH} = -50μA, V _{DD} =V _{C1} , V _{C4} =4.5V, V _{CELLn} =3.2V (n=1,2,3,5)	V _{C4} -0.5V	V _{C4} -0.3V		V	W
V _{OH8}	CB5 pin Pch.ON voltage	I _{OH} = -50μA, V _{DD} =V _{C1} , V _{C5} =4.5V, V _{CELLn} =3.2V (n=1,2,3,4)	V _{C5} -0.5V	V _{C5} -0.3V		V	W

(1) Refer to TEST CIRCUITS for detail information.

(2) When V_{DD} < V_{VR12}-0.1V, DOUT / DRAIN pin voltage (V_{OH2}/V_{OH3}) becomes almost equal to V_{DD}.

$V_{CELLn} = CELLn$ (Ex. V_{CELL1} is a voltage difference between VC1 and VC2)
 $n = 1, 2, 3, 4, 5$, unless otherwise noted.

R5436TxxxBA / R5436TxxxBB Characteristics (Continued)

(Ta = 25°C)

Symbol	Item	Conditions	Min.	Typ.	Max.	Unit	Circuit (1)
I_{LCOUT}	COUt pin off leakage-current	VDD=VC1, $V_{CELLn}=3.4V$, CTLC=VDD, COUt= -14V	-0.1			μA	X
V_{VR}	VR output voltage	VDD=VC1, $V_{CELLn}=3.4V$	3.5	3.6	3.7	V	Y
V_{T_DET}	Detection voltage of TEP temperature protection	VDD=VC1, $V_{CELLn}=3.4V$	V_{T_DET} -0.027	$V_{T_DET}^{(2)}$	V_{T_DET} +0.035	V	Z
V_{T_REL}	Release voltage of TEP temperature protection	VDD=VC1, $V_{CELLn}=3.4V$	V_{T_REL} -0.043	$V_{T_REL}^{(2)}$	V_{T_REL} +0.050	V	Z
t_{T_DET}	TEP detection delay time	VDD=VC1, $V_{CELLn}=3.4V$, $V_{TEP}=0V \rightarrow 2V$	5	8	11	ms	Z
t_{T_REL}	TEP release delay time	VDD=VC1, $V_{CELLn}=3.4V$, $V_{TEP}=2V \rightarrow 0V$	11	16	21	ms	Z
t_{LT}	Broken wire scanning cycle	VDD=VC1, $V_{CELLn}=V_{CBDn}+0.05V$	0.7	1.25	1.8	S	a
V_{HCO1}	VHC pin Nch.ON voltage 1	$I_{OH}=2\mu A$, VDD=VC1, $V_{CELLn}=3.4V$, $V_{MP}=0V$	14.5	15.5	16.5	V	c
V_{HCO2}	VHC pin Nch.ON voltage 2	$I_{OH}=10\mu A$, VDD=VC1, $V_{CELLn}=3.4V$, $V_{MP}=0V$		$V_{HC1}+0.3$	$V_{HC1}+0.5$	V	c
I_{LVHC}	VHC pin off leakage-current	VDD=VC1, $V_{CELLn}=3.4V$, $V_{MP}=0.5V$, $V_{HC}=32V$			0.1	μA	b
I_{SS1}	Supply current 1	VDD=VC1, COUt=OPEN $V_{CELLn} = V_{DET1n} - 0.4V$		12	30	μA	d
I_{SS2}	Supply current 2	VDD=VC1, COUt=OPEN $V_{CELLn} = 1.5V$		6	12	μA	d
V_{STB}	Power ON voltage at standby mode	VDD=VC1=1.5V, $V_{CELLn}=3.4V$ (n=2,3,4,5), At rising edge detection of VMP pin	0.9	1.13	1.35	V	H

(1) Refer to TEST CIRCUITS for detail information.

(2) $V_{T_DET}=20/21 \cdot V_{VR}$, $V_{T_REL}=27/29 \cdot V_{VR}$ (V_{VR} :VR pin output voltage)

TEST CIRCUITS

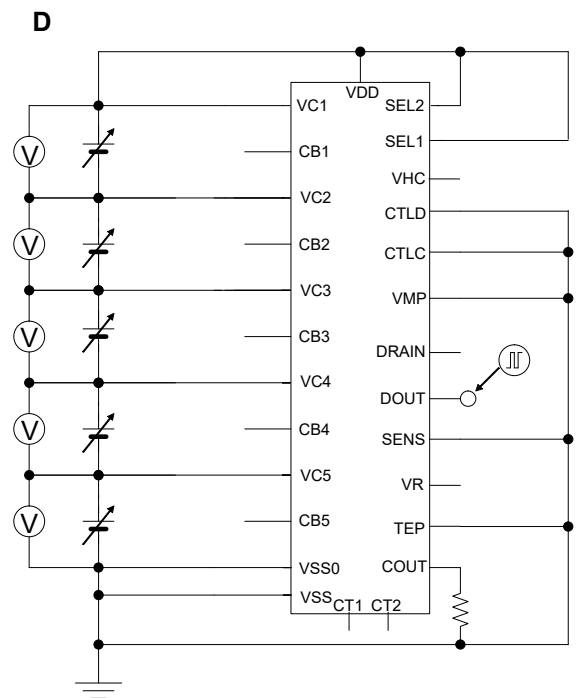
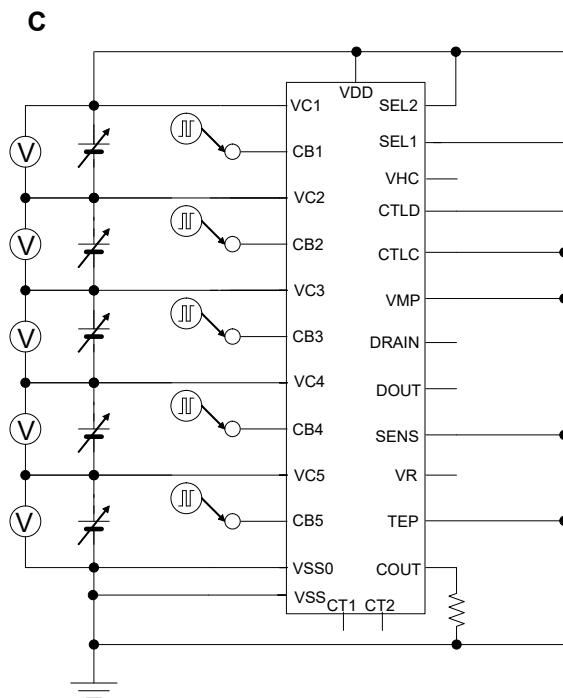
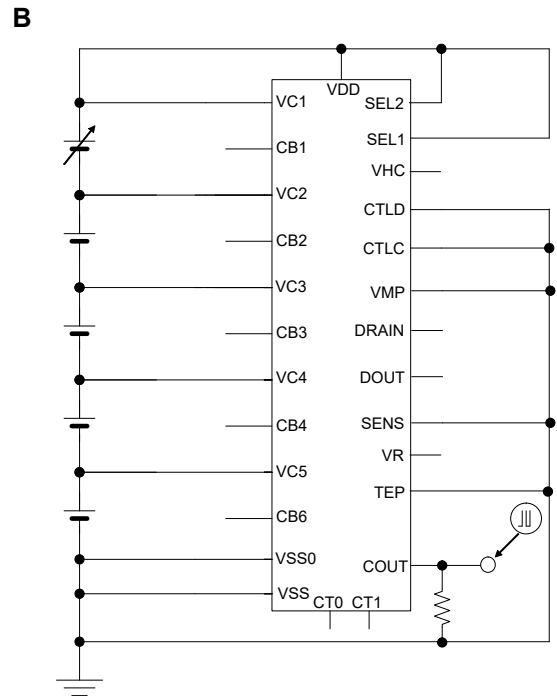
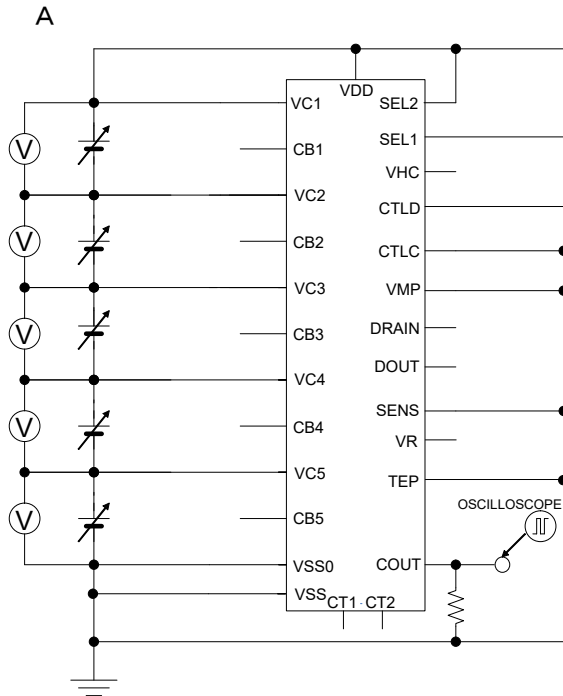

E

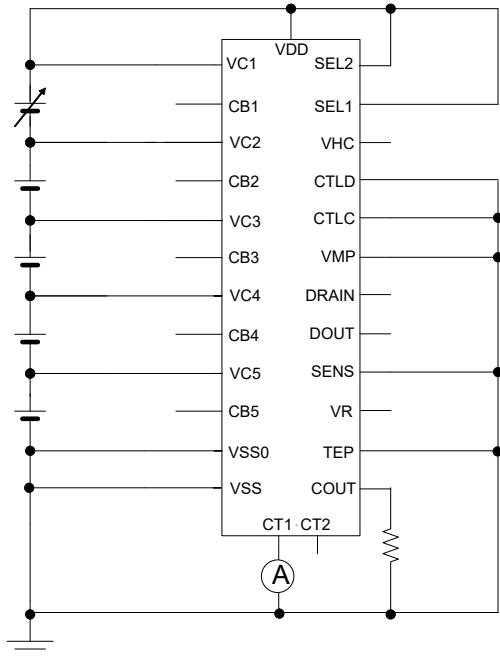

F

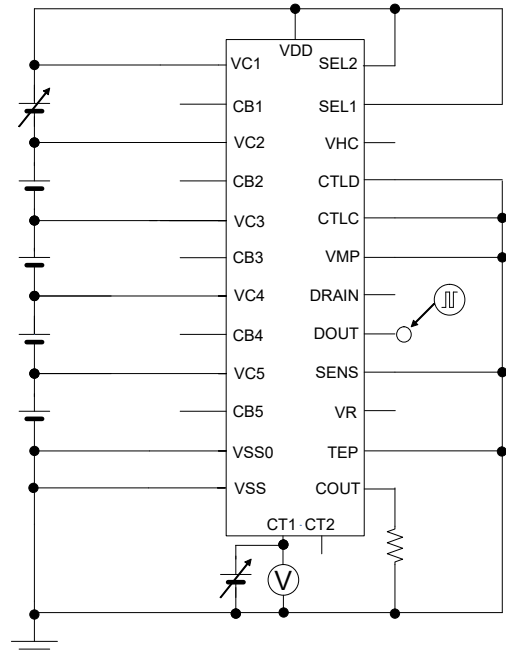

G

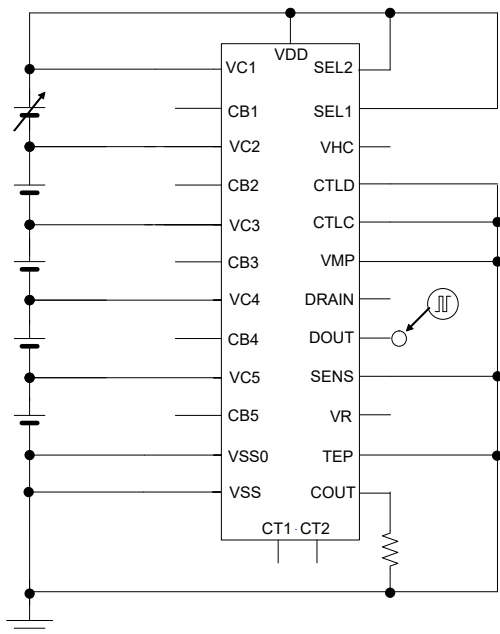

H

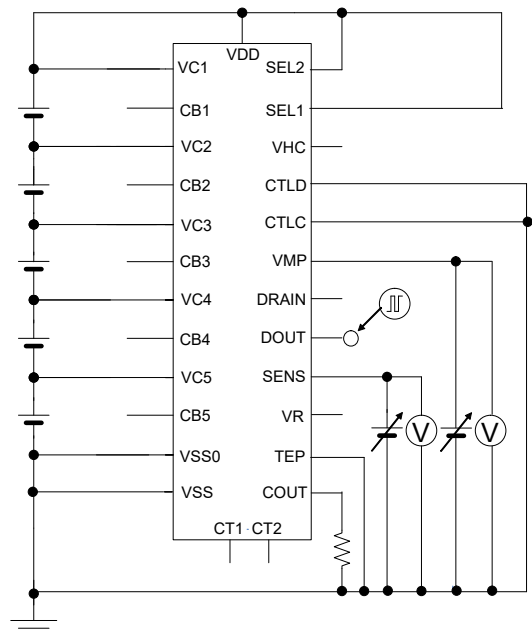

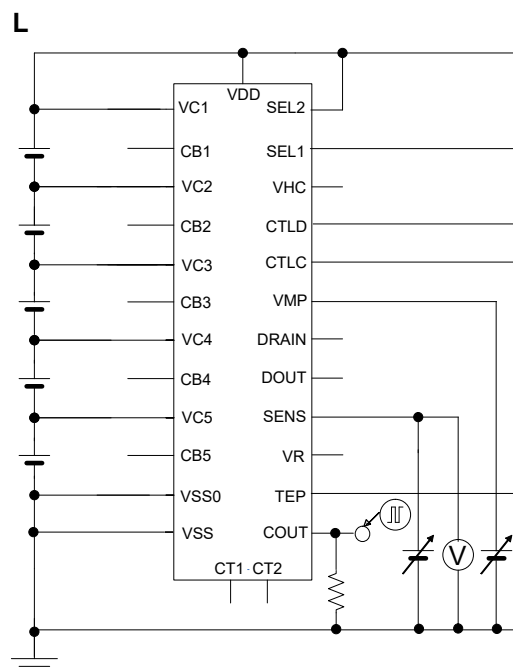
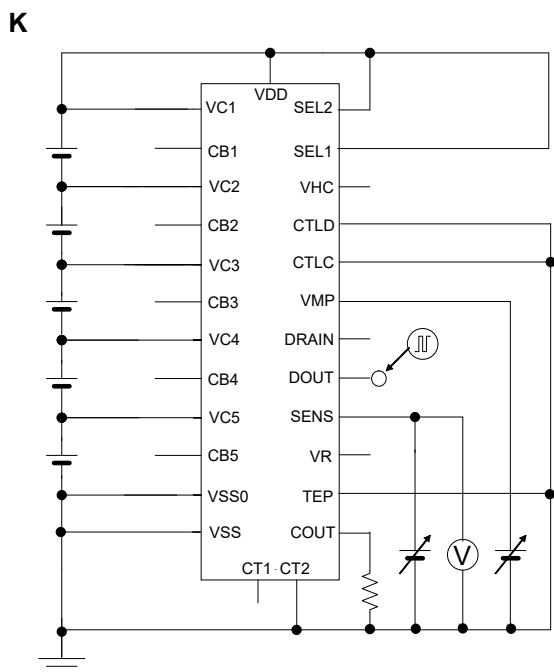
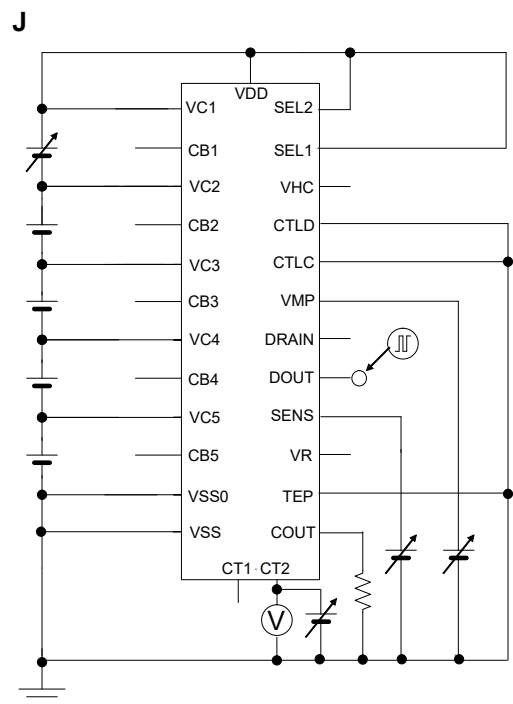
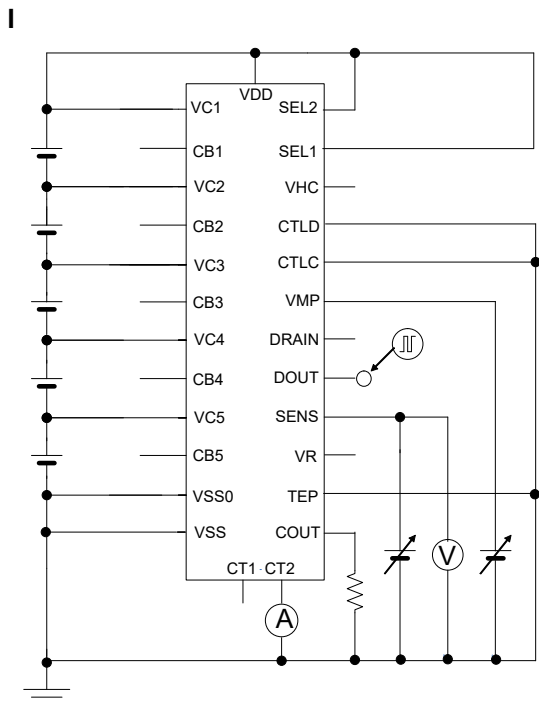

M

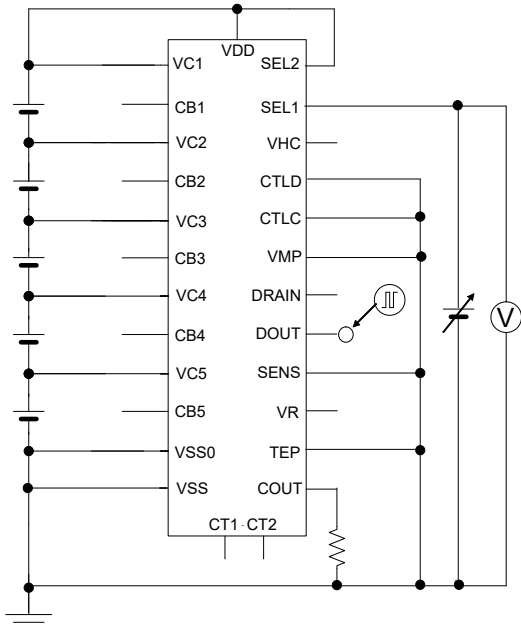

N

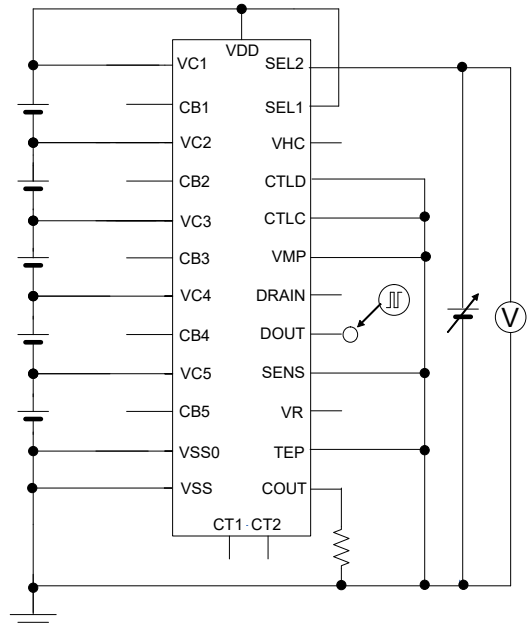

O

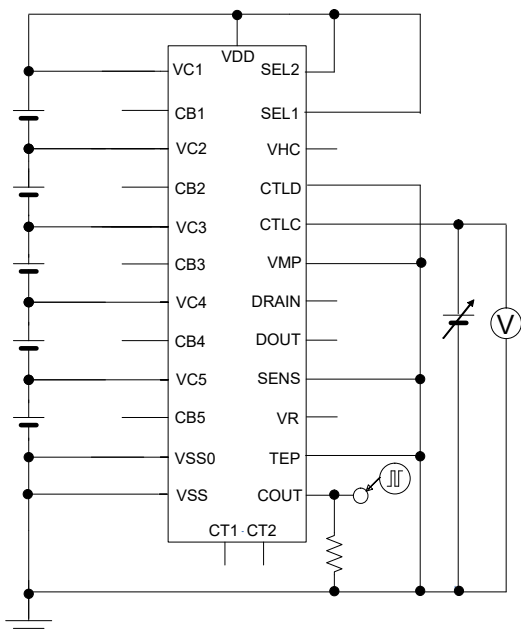

P

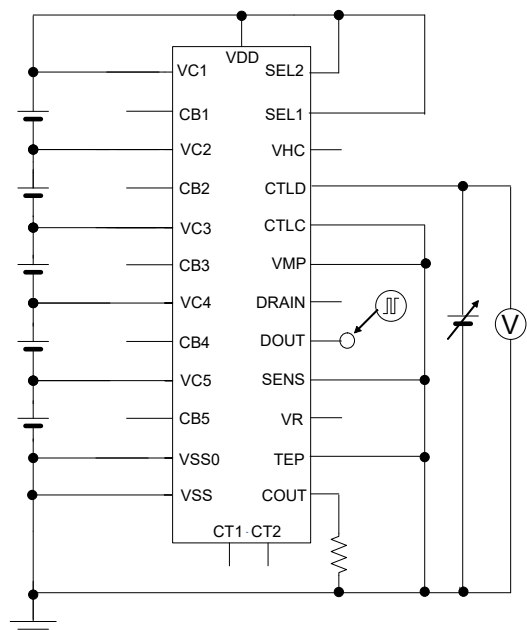

Q

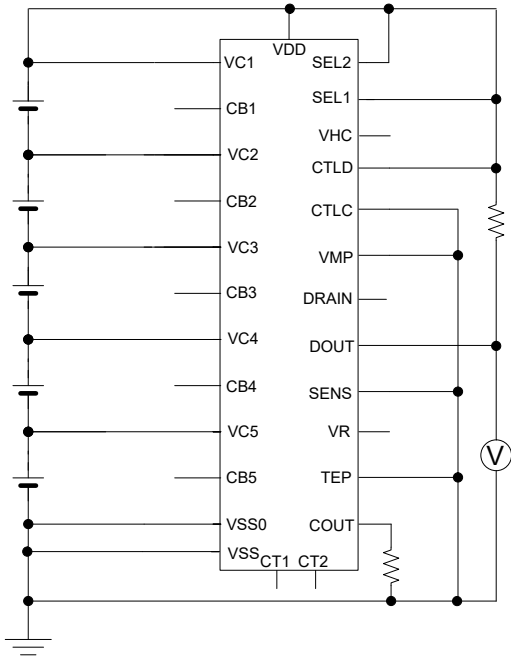

R

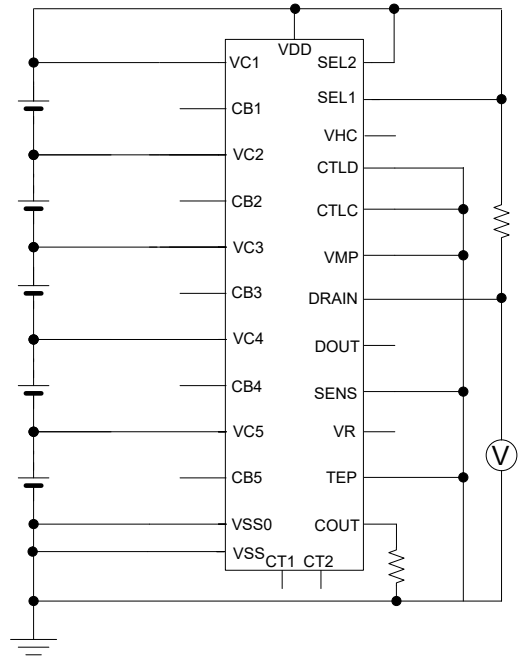

S

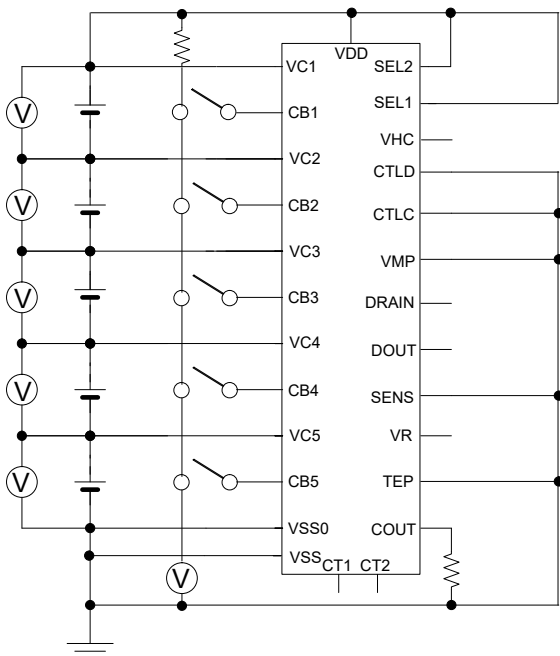

T

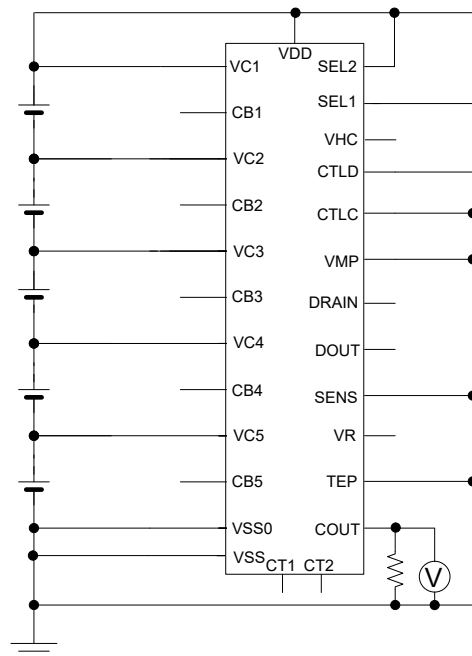

U

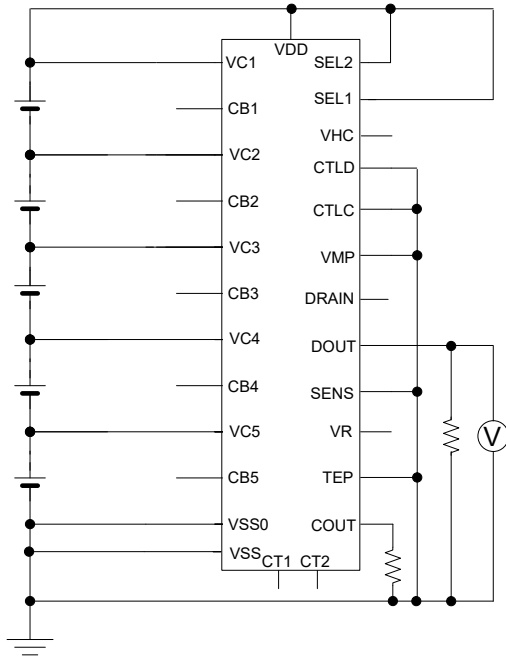

V

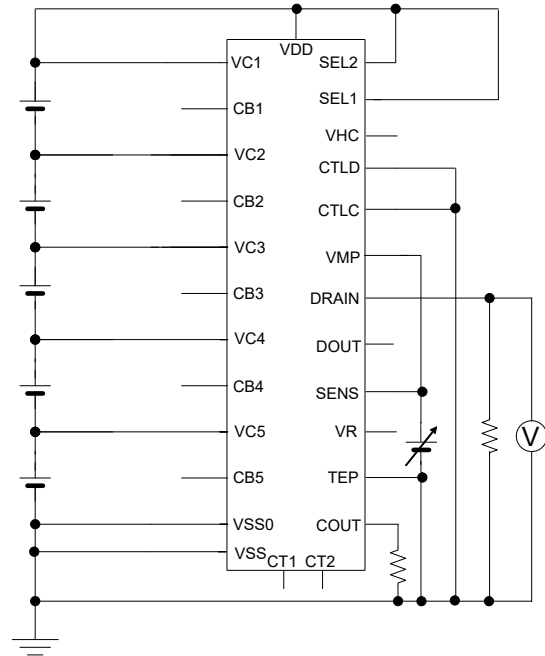

W

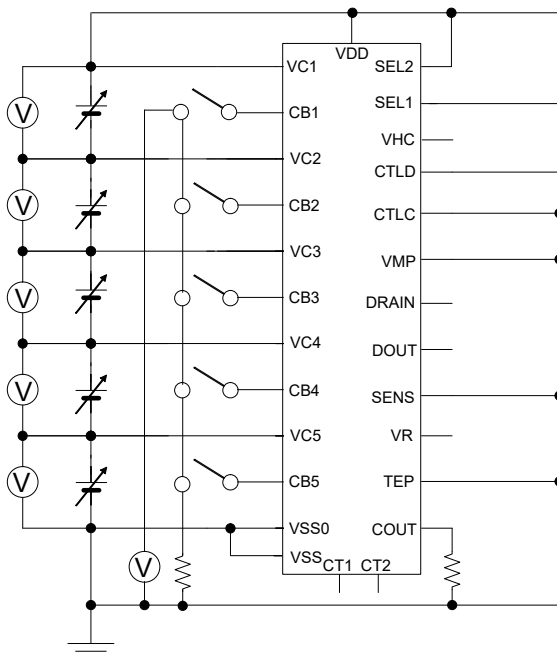

X

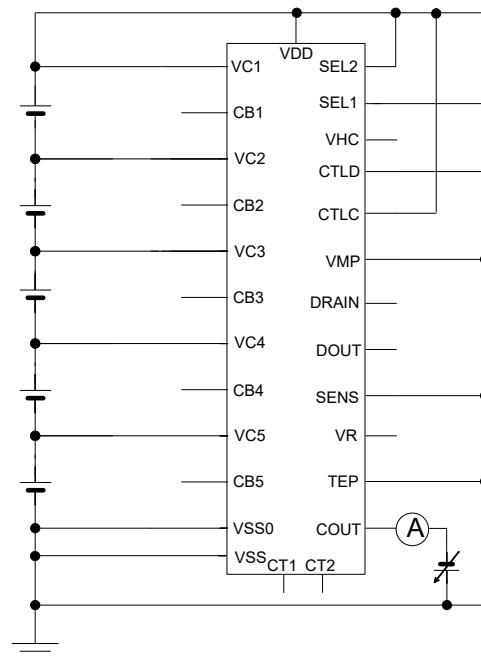

Y

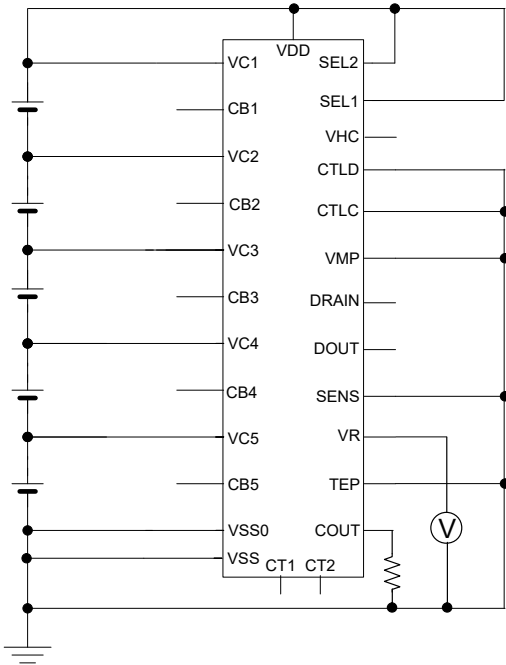

Z

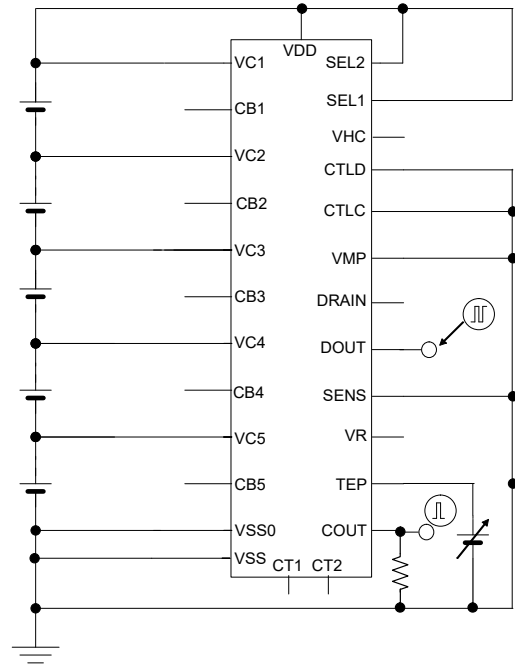

a

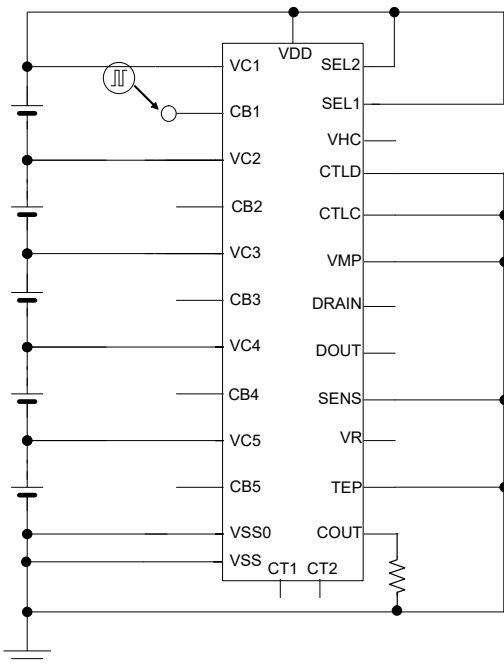

b

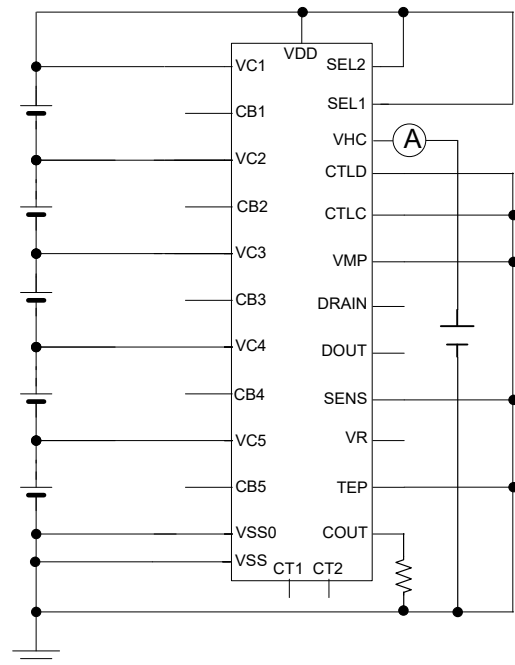

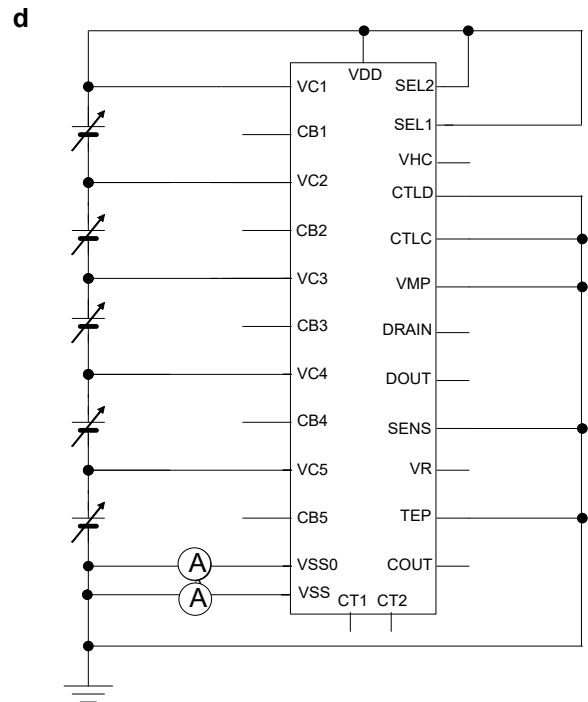
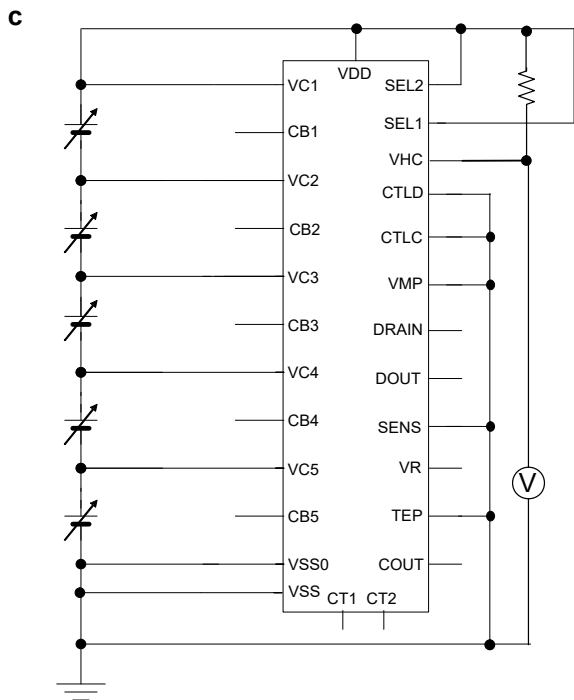

THEORY OF OPERATION

Overcharge Detection: VD1-n (n = 1, 2, 3, 4, 5)

During charging, the device supervises the voltage between VC1 and VC2 pins (the CELL1 voltage), the voltage between VC2 and VC3 pins (the CELL2 voltage), the voltage between VC3 and VC4 pins (the CELL3 voltage), the voltage between VC4 and VC5 pins (the CELL4 voltage), and the voltage between VC5 and VSS0 pins (the CELL5 voltage). If at least one of the cells' voltage becomes more than the overcharge detection voltage, the overcharge is detected, and COUT pin connected to an external pull-down resistor becomes "Hi-z", and it makes the external Nch.FET turn off. Then, the charging stops.

After detecting the overcharge, when all the cell voltage become lower than the overcharge detection voltage by connecting a load, COUT pin becomes "High", and it makes the external Nch.FET turn on, and the charging restarts. Even If all the cell voltage become lower than the overcharge release voltage with no load, COUT pin becomes "High" and the charging is available.

The device has internal fixed output delay times for overcharge detection and overcharge release. When the output delay time passes while any one of cell voltages is more than the overcharge detection voltage, the overcharge is detected. However, all cell voltage becomes lower than the overcharge detection voltage within the overcharge detection delay time, even if anyone of cells' voltage becomes more than the overcharge detection voltage, the overcharge is not detected.

Besides, after detecting the overcharge, any one of their cell voltages becomes more than the overcharge release voltage within the overcharge release delay time, even if all the cell voltage becomes lower than the overcharge release voltage, the device does not release from the overcharge.

Overdischarge Detection: VD2-n (n = 1, 2, 3, 4, 5)

During discharging, the device supervises the voltage between VC1 and VC2 pins (the CELL1 voltage), the voltage between VC2 and VC3 pins (the CELL2 voltage), the voltage between VC3 and VC4 pins (the CELL3 voltage), the voltage between VC4 and VC5 pins (the CELL4 voltage), and the voltage between VC5 and VSS0 pins (the CELL5 voltage). If at least one of the cells' voltage becomes less than the overdischarge detection voltage, the overdischarge is detected, and DOUT pin becomes "Low", and it makes the external Nch.FET turn off. Then, the discharging stops.

The release condition from the overdischarge detection is different depending on optional functions. One is the latch type, after detecting the overdischarge, when the battery becomes higher than the overdischarge release voltage by connecting a charger, DOUT pin becomes "High". And, the other is the voltage release type, when the cell voltage becomes higher than the overdischarge release voltage, the device releases from the overdischarge even if the charger is not connected, and DOUT pin becomes "High".

An output delay time for overdischarge detection is settable by the external capacitor (C_{CT1}) connected to CT1 pin. When the output delay time passes while any one of each cell voltage is lower than the overdischarge detection voltage, the overdischarge is detected. However, all cell voltage becomes higher than the overdischarge detection voltage within the overdischarge detection delay time even if anyone of cells' voltage becomes lower than the overdischarge detection voltage, the overdischarge is not detected. An output delay time for overdischarge release is fixed internally.

After detecting the overdischarge, the device stops unnecessary circuits to reduce the consumption current to a minimum when VMP pin becomes “High”. DOUT pin, which is CMOS output, outputs the internal regulator’s voltage (about 12 V) at “High” level and outputs VSS pin voltage at “Low” level.

Discharge Overcurrent Detection: VD3-n (n = 1, 2) and Short-circuit Detection

During discharging, the device supervises SENS pin voltage (V_{SENS}).

The discharge overcurrent is detected when SENS pin voltage (V_{SENS}) becomes in between the discharge overcurrent detection voltage (V_{DET3n}) and the short-circuit detection voltage (V_{SHORT}) owing to a large load, and the short-circuit is detected when V_{SENS} becomes more than V_{SHORT} . Then, to prevent from flowing large current to circuits, DOUT pin is set to “Low” and the external FET is turned OFF.

The device has two detection thresholds to detect the discharge overcurrent. Each detection threshold has the output delay time each other. The discharge overcurrent detection delay time 2 (t_{VDET32}) is set to be shorter than the discharge overcurrent detection delay time 1 (t_{VDET31}). An output delay time for discharge overcurrent detection is settable by the external capacitor (C_{CT2}) connected to CT2 pin. When V_{SENS} becomes lower than V_{DET3n} within the output delay time even if V_{SENS} is in between V_{DET3x} and V_{SHORT} , the discharge overcurrent is not detected. The output delay times for discharge overcurrent release and short-circuit are fixed internally.

Connect an external resistor for discharge overcurrent release among each drain of the external FETs connected to DRAIN, COUT, and DOUT pins. After detecting the discharge overcurrent, or the short-circuit, turn ON the external FET connected to DRAIN pin, and connect a resistor for overcurrent release to VSS. When load is released and opened after detecting the discharge overcurrent or the short-circuit, The VMP pin voltage (V_{VMP}) is pulled down to VSS via the resistor for the overcurrent release, and V_{VMP} becomes less than V_{REL3} . After a certain delay time, the discharge overcurrent detection state or the short-circuit detection state is released. When the discharge overcurrent detection is released, the external FET connected to DRAIN pin is turned OFF, and the resistor for the overcurrent release is disconnected from VSS.

Charge Overcurrent Detection: VD4

During charging or discharging, the device supervises SENS pin voltage (V_{SENS}). When a large current flow by charging with an inappropriate charger, SENS pin voltage becomes less than the charge overcurrent detection voltage, and the charge overcurrent is detected. COUT pin with the external pull-down resistor becomes “Hi-z”. And, tuning OFF the external FET can prevent from flowing large current to circuits.

When SENS pin voltage (V_{SENS}) becomes higher than V_{DET4} within the output delay time even if V_{SENS} becomes lower than the charge overcurrent detection voltage, the charge overcurrent is not detected. The output delay times for charge overcurrent detection and charge overcurrent release are fixed internally.

To release from the charge overcurrent, connect a load without the charger, and VMP pin voltage has to become higher than the charge overcurrent release voltage over the charge overcurrent release delay time.

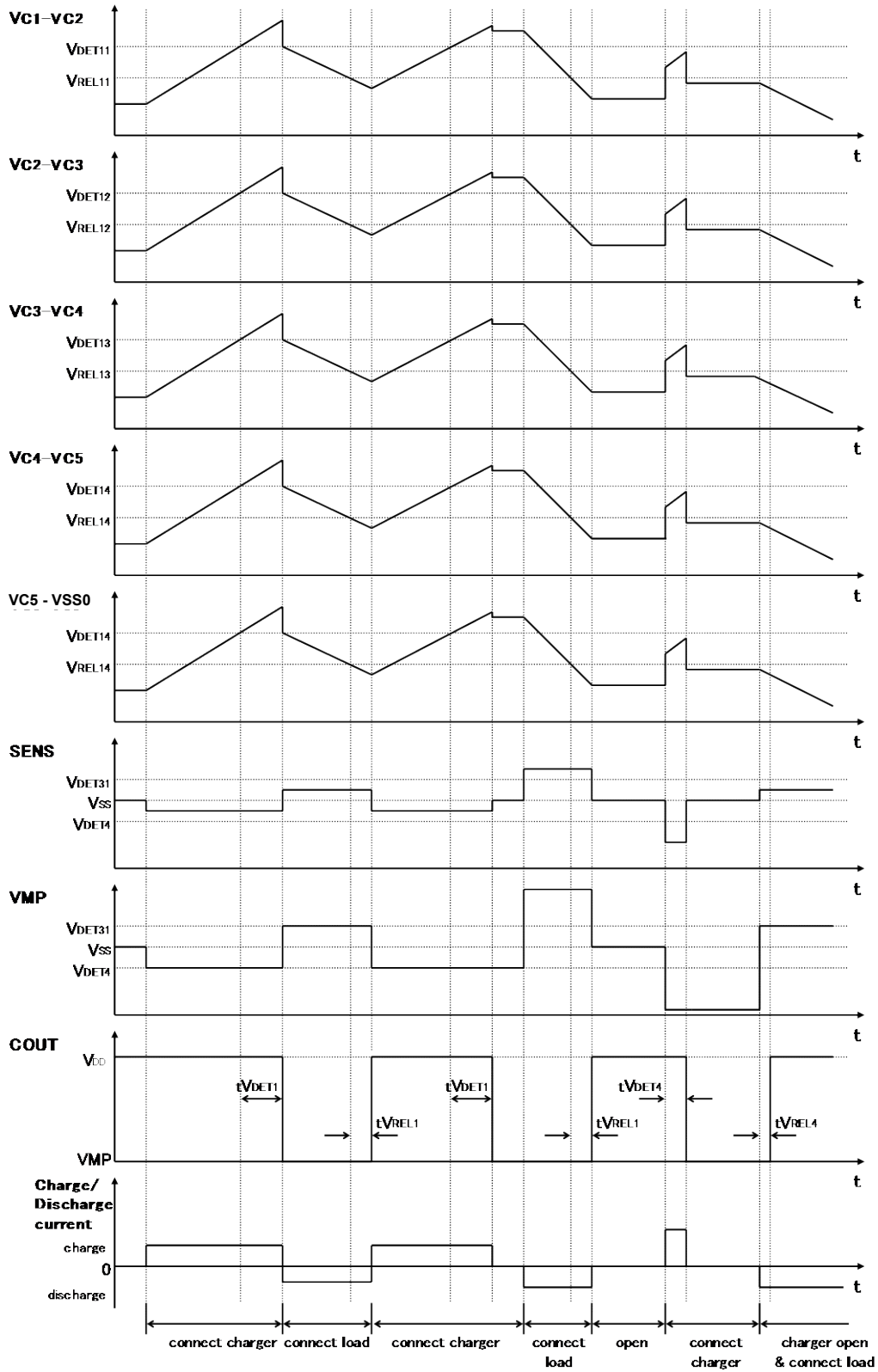

Overcharge / Charge Overcurrent Operation Timing Chart

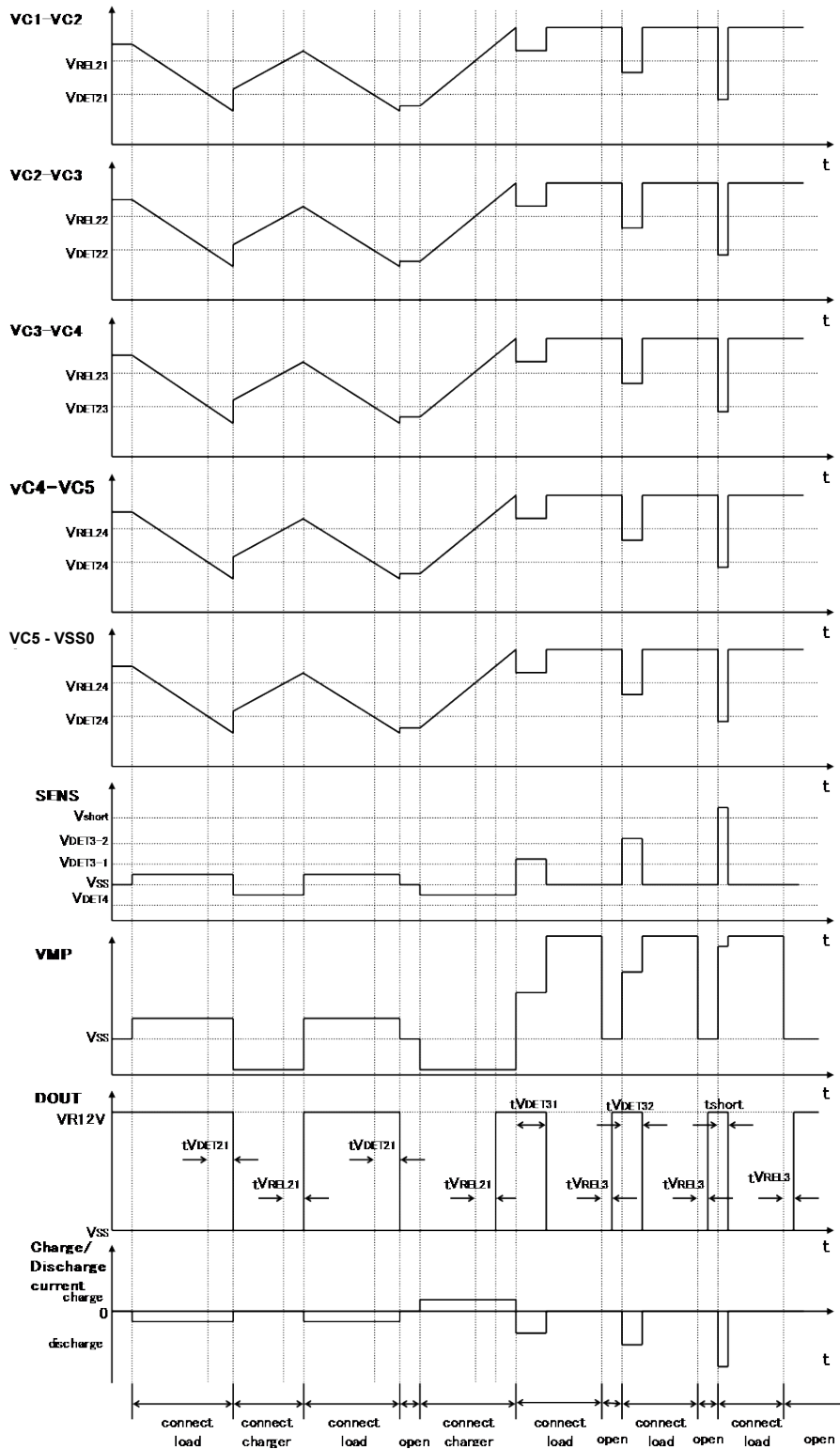

Overdischarge / Discharge Overcurrent / Short-circuit Operation Timing Chart

Standby Mode

This device can change from normal mode to standby mode when overdischarge is detected and VMP pin voltage (V_{VMP}) becomes higher than V_{STB} . In the standby mode, the device stops unnecessary circuits to reduce the consumption current to a minimum. At that time, VR pin output voltage becomes equal to the V_{SS} level. And, this device can return to the normal mode when V_{VMP} becomes lower than V_{STB} by connecting a charger.

Cell Imbalance

When any one of CELLS detects an overcharge and either one detects an overdischarge, COUT pin becomes “Hi-z” and DOUT pin becomes “Low”.

SEL1 and SEL2 Pins

SEL1 and SEL2 pins are switching-control pins to select among 3- / 4- / 5-cell protection. When using for the 4-cell protection, connecting SEL1 pin to VSS and the SEL2 pin to VDD is required to stop the 5th cell protection circuit and shut signals. The overdischarge is not detected when VC5 pin is shortened to VSS0.

When using for the 3-cell protection, likewise, connecting SEL1 pin to VDD and SEL2 pin to VSS is required to stop the 5th and 4th cells protection circuits and shut signals. The overdischarge is not detected when VC4 and VC5 pins are shortened to VSS0. SEL1 / SEL2 pin must be fixed to VDD / VSS when using the 3- / 4- / 5-cell protection. Setting SEL1 and SEL2 pins can select disabling/enabling the open-wire detection⁽¹⁾ and the shorten mode 1/2. Refer to the following table for details of the operation mode.

Operation Modes

Input Voltage ⁽²⁾		Operation Mode
SEL1 Pin	SEL2 Pin	
High	High	Enable the 5-cell protection mode
Low	High	Enable the 4-cell protection mode
High	Low	Enable the 3-cell protection mode
Low	Low	Disable the open-wire detection mode for 5-cell protection
Low	Middle	Disable the open-wire detection mode for 4-cell protection
Middle	Low	Disable the open-wire detection mode for 3-cell protection
Middle	Middle	Enable the delay time shorten mode 1 (approx.1/70) for 5-cell protection
Middle	High	Enable the delay time shorten mode 2 (approx.4 ms) for 5-cell protection
High	Middle	Enable the open-wire detecting test for 5-cell protection

⁽¹⁾ R5436TxxxBB does not support the open-wire detection.

⁽²⁾ “High”: VDD level, “Middle”: $(VDD/2-0.5)$ V to $(VDD-3)$ V, “Low”: VSS level

CTLC and CTLD Pins

When using cascade connection, the R5436T can transfer each state of overcharge, overdischarge, and open-wire detections by connecting between COUT and CTLC pins and between DOUT and CTLD pins. When not using it, CTLC and CTLD pins must be connected to VSS.

When CTLC / CTLD pin voltage is higher than the value of “High” threshold voltage 1 (V_{CTLC1H} / V_{CTLD1H}), or when CTLC / CTLD pin voltage is lower than the value of “High” threshold voltage 2 (V_{CTLC2H} / V_{CTLD2H}), COUT / DOUT pin becomes “High” after normal operation. By applying a voltage of between V_{CTLC1H} and V_{CTLC2H} to CTLC pin, COUT pin with an external pull-down resistor becomes “Hi-z” forcedly. And, by applying a voltage of between V_{CTLD1H} and V_{CTLD2H} to CTLD pin, DOUT pin with an external pull-down resistor becomes “Low” forcedly. Don’t make CTLC and CTLD pins open. The following table indicates a relationship between the control pins (CTLC and CTLD) and the state of the external FETs for COUT and DOUT pins.

External FET’s state by CTLx pins

CTLC / CTLD pins	External FET for COUT / DOUT pins
$2V_{DD}$ to V_{CTLC1H} / V_{CTLD1H}	ON (Normal operation)
V_{CTLC1H} / V_{CTLD1H} to V_{CTLC2H} / V_{CTLD2H}	Forced OFF
V_{SS} to V_{CTLC2H} / V_{CTLD2H}	ON (Normal operation)

When $V_{DD} = 17\text{ V}$ (Refer to “*Electrical Characteristics*”),

V_{CTLC1H} / V_{CTLD1H} : Typ. 18.1 V

V_{CTLC2H} / V_{CTLD2H} : Typ. 16.1 V

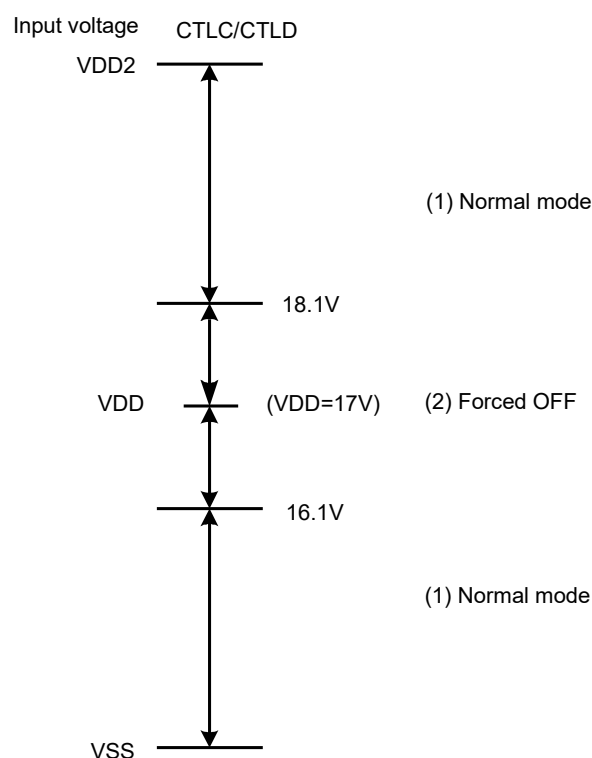

CT1 and CT2 Pins

CT1 and CT2 pins are used for setting each output delay time of the overdischarge detection (t_{VDET2}), and the discharge overcurrent detection 1/2 (t_{VDET31} / t_{VDET32}) by connecting external capacitors C_{CT1} and C_{CT2} .

t_{VDET2} can be set with CT1 pin. t_{VDET31} and t_{VDET32} can be set with CT2 pin. Each delay time can be calculated by following Equation 1:

$$CV = i\Delta t \dots \dots \dots \text{Equation 1}$$

- Delay time (t_{VDET2}) setting with external capacitor (C_{CT1})

By substitution of Equation1,

$$t_{VDET2} = C_{CT1} \times V_{DCT1} / I_{CT1} \dots \dots \dots \text{Equation 2}$$

If $C_{CT1} = 33 \text{ nF}$, $V_{DCT1} = 1.8 \text{ V}$, $I_{CT1} = 500 \text{ nA}$ (Refer to “*Electrical Characteristics*”).

When substituting values to Equation 2, t_{VDET2} is as follows:

$$\begin{aligned} t_{VDET2} &= 33 \text{ nF} \times 1.8 \text{ V} / 500 \text{ nA} \\ &= 118.8 \text{ ms} \end{aligned}$$

- Delay time (t_{VDET31} , t_{VDET32}) setting with external capacitor (C_{CT2})

By substitution of Equation1,

$$t_{VDET31} = C_{CT2} \times V_{DCT2} / I_{CT2} \dots \dots \dots \text{Equation 3}$$

$$t_{VDET32} = t_{VDET31} / 6 \dots \dots \dots \text{Equation 4}$$

If $C_{CT1} = 3.3 \text{ nF}$, $V_{DCT1} = 1.5 \text{ V}$, $I_{CT1} = 500 \text{ nA}$ (Refer to “*Electrical Characteristics*”).

When substituting values to Equation 3 / Equation 4, t_{VDET31} and t_{VDET32} are as follows:

$$\begin{aligned} t_{VDET31} &= 3.3 \text{ nF} \times 1.5 \text{ V} / 500 \text{ nA} \\ &= 9.9 \text{ ms} \end{aligned}$$

$$\begin{aligned} t_{VDET32} &= 9.9 \text{ ms} / 6 \\ &= 1.65 \text{ ms} \end{aligned}$$

Cell Balance Function

When the cell voltage exceeds the cell balance detection voltage (V_{CBDn} , $n=1,2,3,4,5$), CBn pin become “High” by cell balancing. By turning ON an external Nch.FET for cell balance, a current flow through the discharge path in parallel with the cell in order to reduce the charging current or to discharge the cell voltage. And, when the cell voltage is less than the cell balance release voltage (V_{CBRn} , $n=1,2,3,4,5$), CBn pin become “Low” after

the cell balancing is released, and the external Nch.FET is turned OFF. When not using this function, CBn pin must be open.

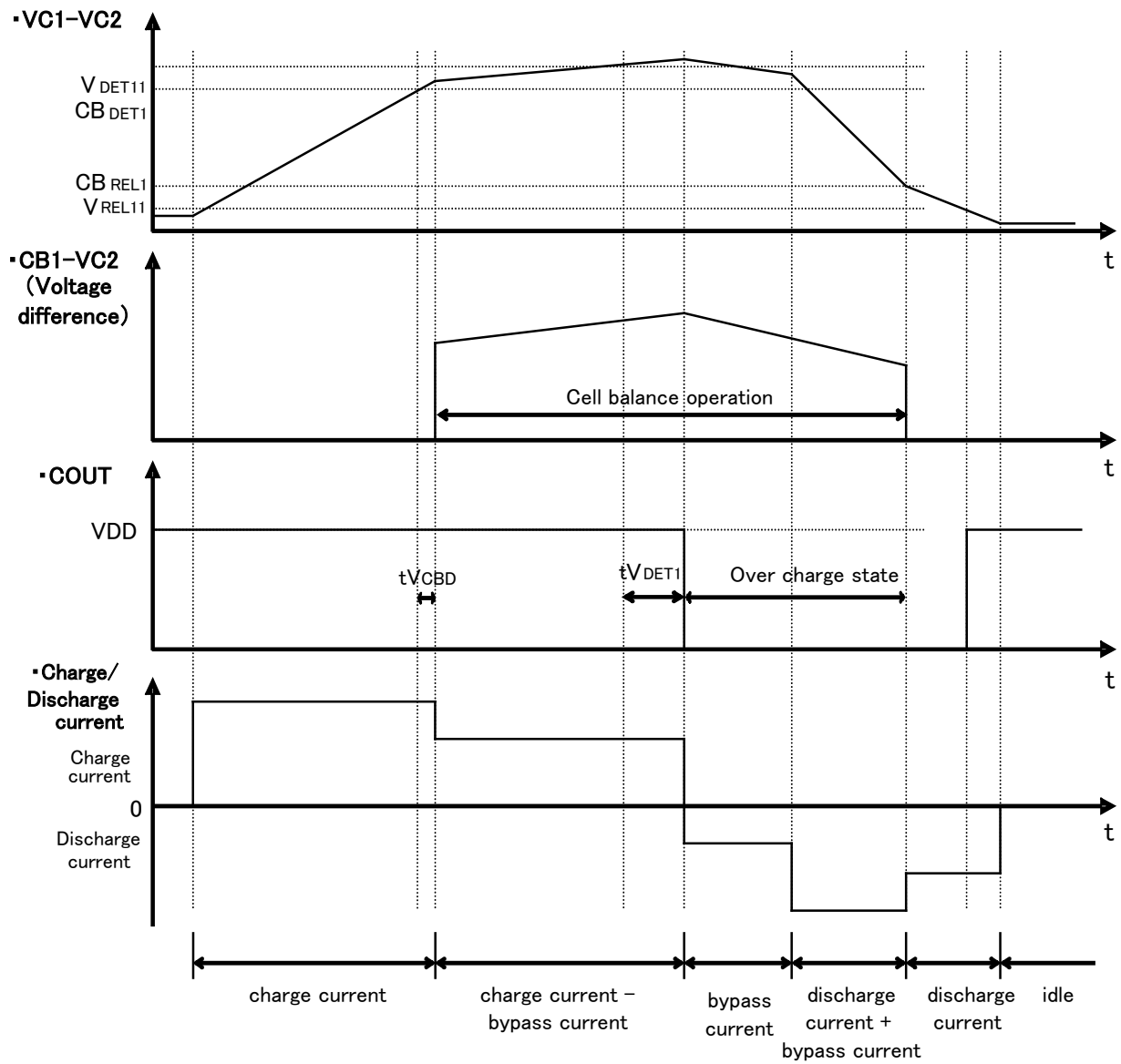

CELL1 Balancing Timing Chart

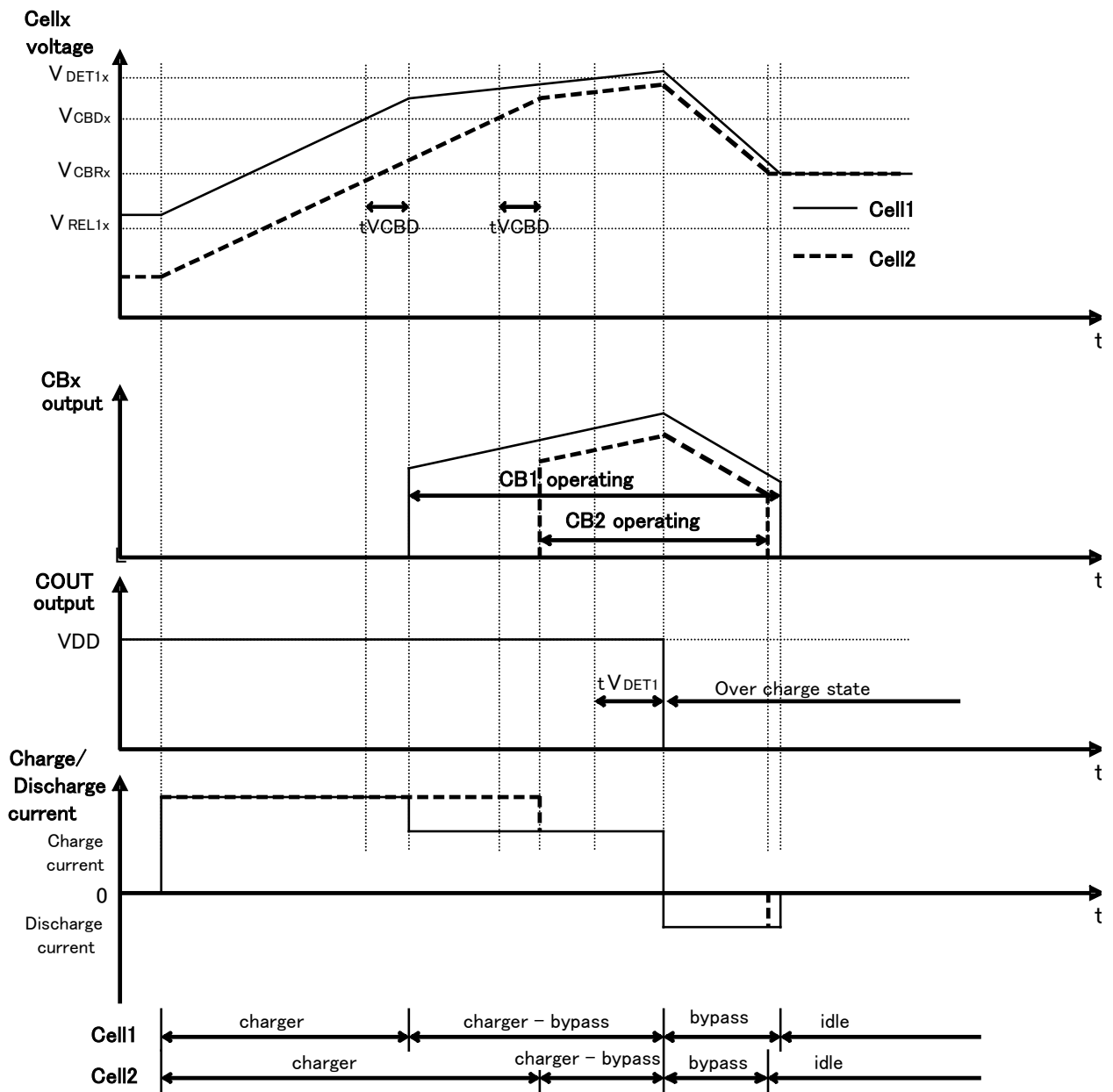

CELL1/2 Balancing Timing Chart

Open-wire Detection (R5436TxxxBA only)

When using the 5-cell protection, the voltage of VDD (= VC1) becomes lower than VC2 voltage if the connection between the battery and VDD (= VC1) is open. And, the voltage of VSS (= VSS0) becomes higher than VC5 voltage if the connection between the battery and VSS (= VSS0) is open. The voltage variation is detected as "Open-wire". When the open-wire is detected, COUT becomes "HI-z" and DOUT becomes "Low". But, if VC1 or VSS0 line is cut off when each VC1 and VSS0 pins are connected with separate lines, only DOUT pin will become "Low". Likewise, as for an open-wire detection between VDD and VSS pins, if VDD or VSS line is cut off, COUT pin will become "Hi-z" and DOUT pin will become "Low".

Open-wire detection for VC2, VC3, VC4, and VC5 is performed at interval of 1.25 seconds. The cell switch for VC1, VC3, and VC5 and the cell switch for VC2 and VC4 are alternately turned ON by even_sw and odd_sw signals. The internal impedance between pins, which are turned the switch ON, is lowered for about 140 ms. If not detecting the open-wire, this cycle will exit and the next cycle will start. If detecting the open-wire, the VC voltage will be shifted according to the difference of the internal impedance caused by turning ON either of two switches. This voltage change is detected during the delay time of 0.5 ms or more, the open-wire detection works. Then, COUT pin becomes "Hi-z" and DOUT pin becomes "Low". By applying a certain voltage to SEL1 and SEL2 pins, the open-wire detection for VC2, VC3, VC4, and VC5 is disabled. The open-wire detection is disabled even when this device is in standby mode - but the open-wire detection for VDD and VSS lines is enabled.

When using the 10-cell protection, if VSS of the higher-voltage device and VDD of the lower-voltage device in cascade connection are connected with the battery's line, an open-wire in this line cannot be detected.

[Limitations of Open-wire detection for VC2, VC3, VC4, and VC5]

When using the open-wire detection for VC2, VC3, VC4, and VC5, confirm the limitations below:

- The cycle time of open-wire detection is 1.25 second, and the open-wire detection is performed for 140 ms in each cycle. The device controls these internal-set times.
- When the battery voltage is lower even when this device is not in standby, an open-wire might not be detected due to some factors: the device's distribution, the cell balancing in the battery, the operating environment, the characteristics of the external components, etc.
- During the overcharge detection delay time, the device does not shift to the open-wire detection until the overcharge detection is finished. The overcharge detection does not start even if the battery voltage is higher than the overcharge detection voltage. After the completion of the open-wire detection, the overcharge detection will start if the battery voltage is more than the overcharge detection voltage. That is, the overcharge detection delay time increases for the time required for the open-wire detection.
- Likewise, the device does not shift to the open-wire detection during the overdischarge detection delay time, and the device does not start the overdischarge detection when the battery voltage is less than the overdischarge detection voltage during the open-wire detection. But, after the completion of the open-wire detection, the overdischarge detection delay time increases for the time required for the open-wire detection.

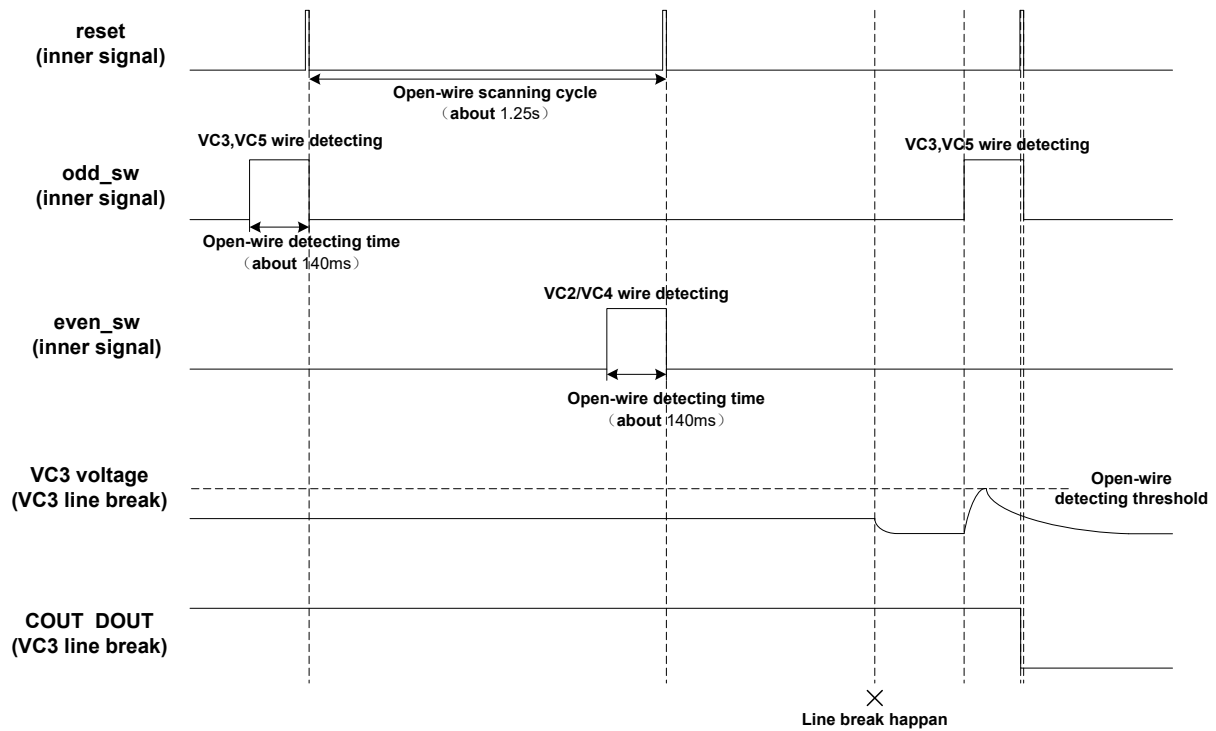

Open-wire Detection Timing Chart

Temperature Protection by External NTC

The temperature protection is realized with VR and TEP pins. VR pin supplies a source voltage to be divided by a series of resistors of R_{TEP} and NTC. The divided voltage becomes an input to TEP pin.

When rising of the temperature under the NTC's supervising, TEP pin voltage, which is the divided voltage, rises depending on a reduction of the NTC resistance value. When the delay time (t_{T_DET}) has passed while holding the divided voltage being higher than the temperature protection detection voltage (V_{T_DET}), the temperature protection will function, and changing COUT pin to "Hi-z" and DOUT pin to "Low" can stop charging/ discharging. After the temperature falling, the delay time (t_{T_REL}) has passed while holding the divided voltage being lower than the temperature protection release voltage (V_{T_REL}), COUT and DOUT pins return "High", and charging / discharging is available.

VR pin cannot supply a large current because of supplying a source voltage for the voltage divider. In standby mode, the temperature protection stops since VR pin becomes "Low" to reduce the consumption current. When using the temperature protection at desired temperature, each resistance value of NTC and R_{TEP} can be calculated by following Equation:

$$\frac{R_{TEP}}{R_{TEP} + R_{NTC}} \times VR = \frac{20}{21} \times VR$$

$$R_{TEP} = 20 R_{NTC}$$

For example, when using the following requirements:

NTC resistor: SNS104B24B24360FE1L050ET

Available temperature for protection: 65°C

$R_{NTC} = 17.63 \text{ k}\Omega$ (at 65°C)

Then,

$$\begin{aligned} R_{TEP} &= 20 \times R_{NTC} \\ &= 352.6 \text{ (k}\Omega\text{)} \end{aligned}$$

As a result, choose a nearest value and normal type resistance: $R_{TEP}=348\text{k}\Omega$.

APPLICATION INFORMATION

For battery pack assembly, it is recommended to start with the VSS connection, followed by the (+) terminal of the lowest cell in ascending voltage order.

Typical Application Circuits 1

3-cell Protection Battery Charger

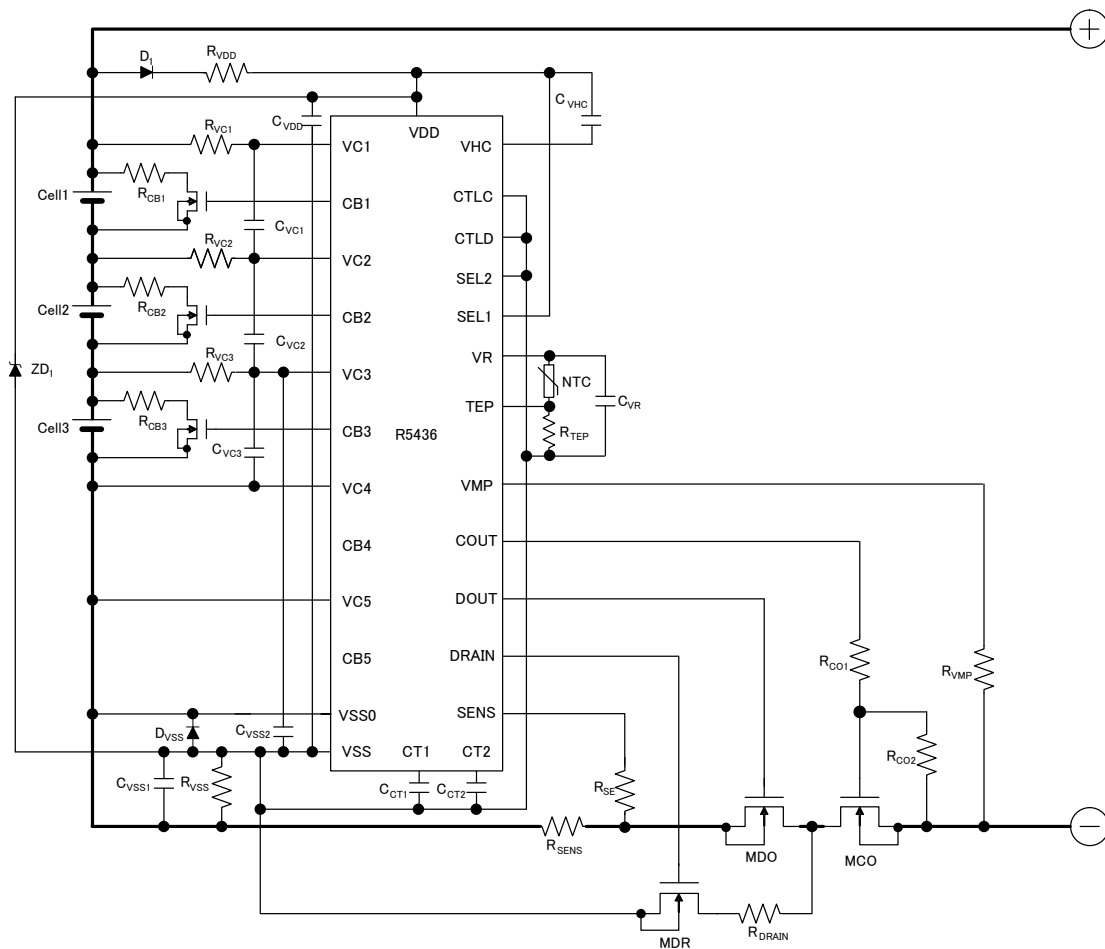

Typical Application Circuit for 3-cell Protection Battery Charger

Typical Application Circuits 2

4-cell Protection Battery Charger with Cell-balancing Disabled

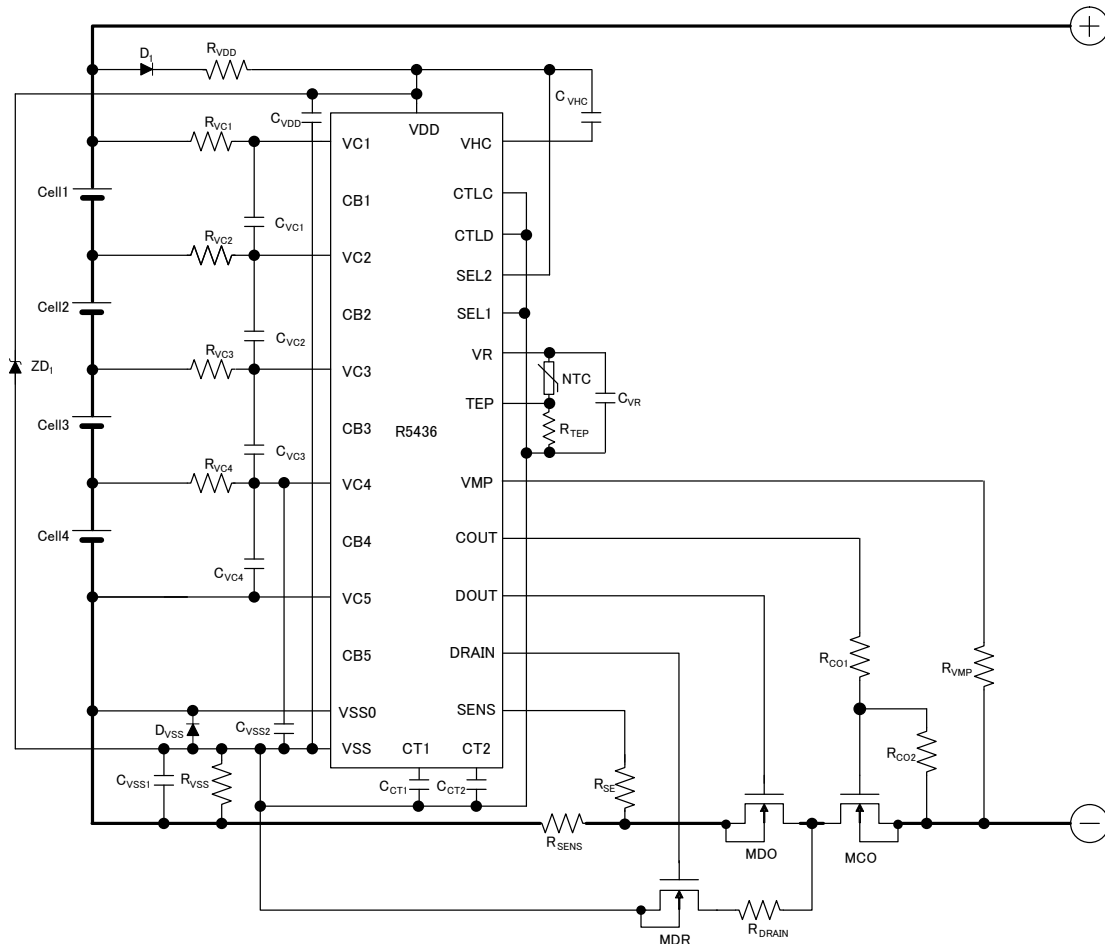

Typical Application Circuit for 4-cell Protection Battery Charger with Cell-balancing Disabled

4-cell Protection Battery Charger with Cell-balancing Enabled

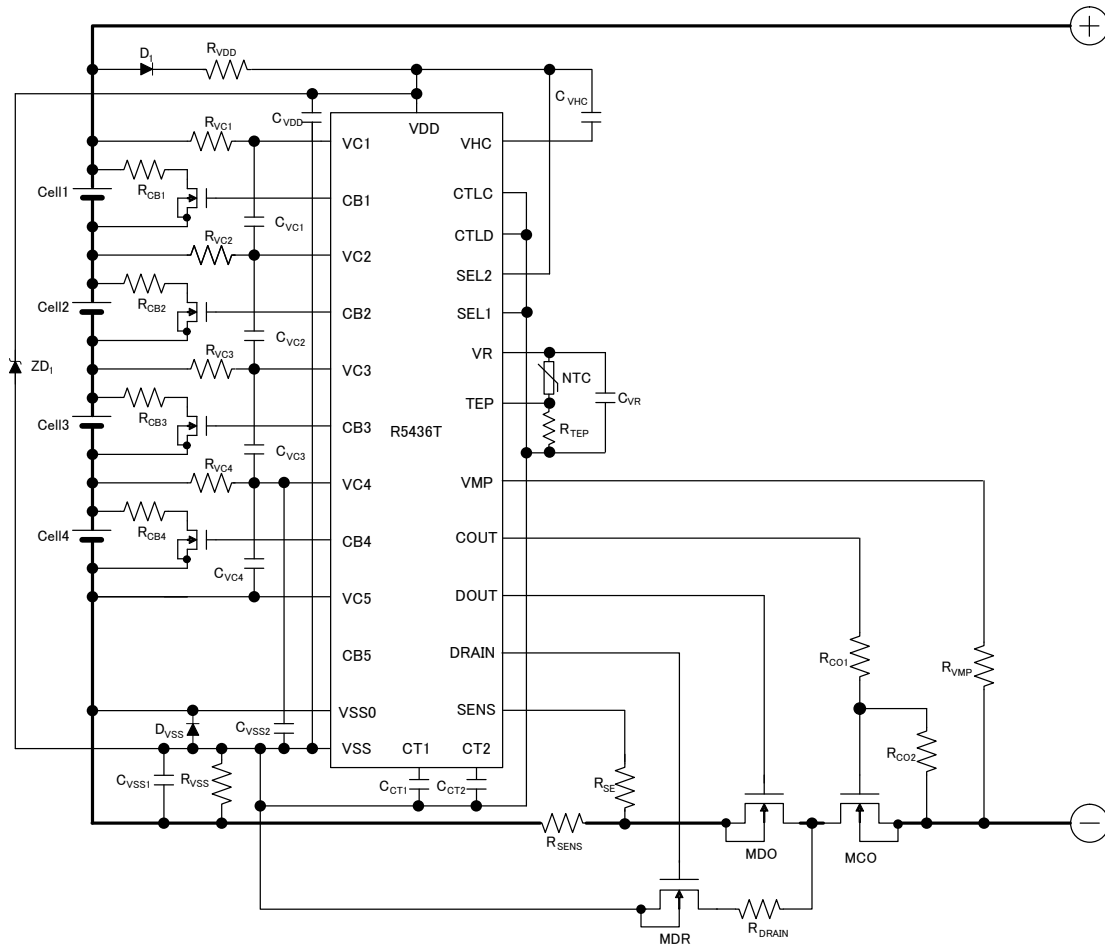

Typical Application Circuit for 4-cell Protection Battery Charger with Cell-balancing Enabled

Typical Application Circuits 3

5-cell Protection Battery Charger with Cell-balancing Enabled

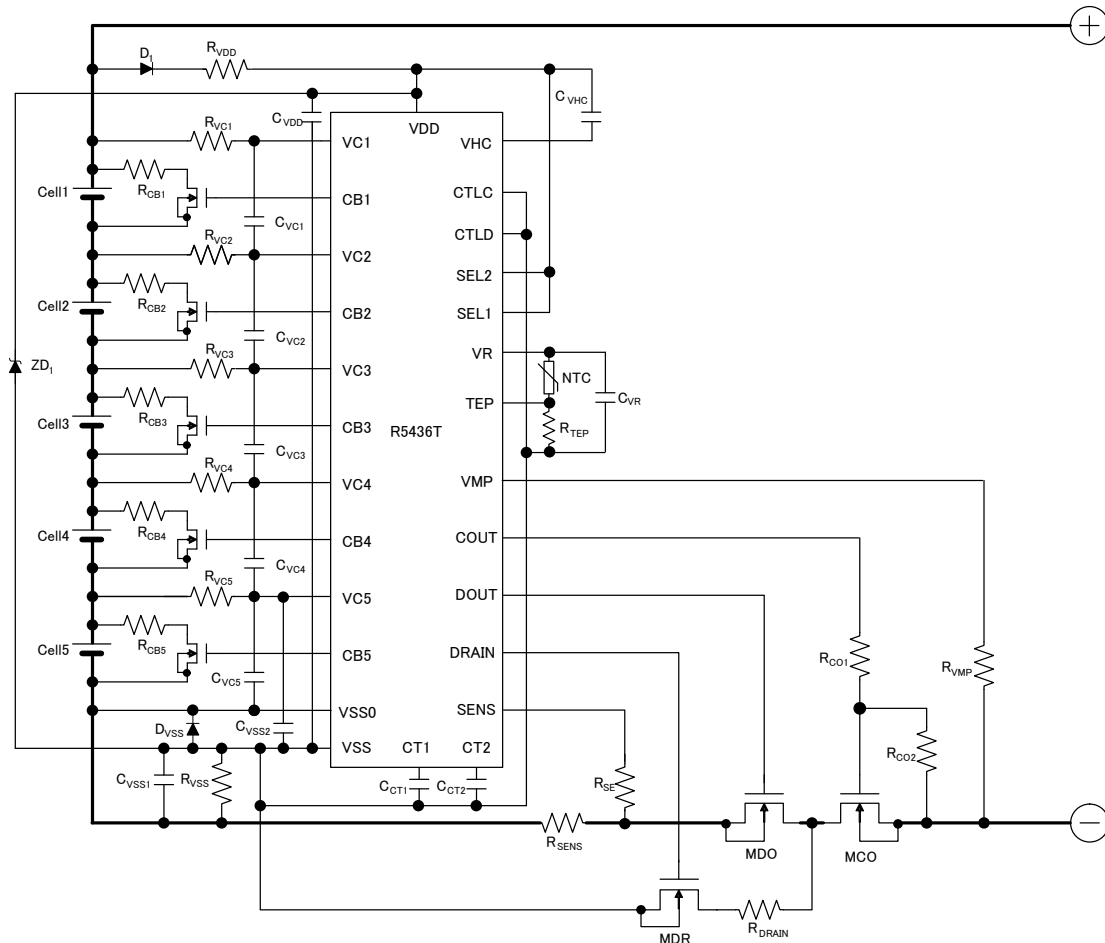

Typical Application Circuit for 5-cell Protection Battery Charger with Cell-balancing Enabled

Typical Application Circuits 4

6-cell Protection Battery Charger with Cell-balancing Enabled

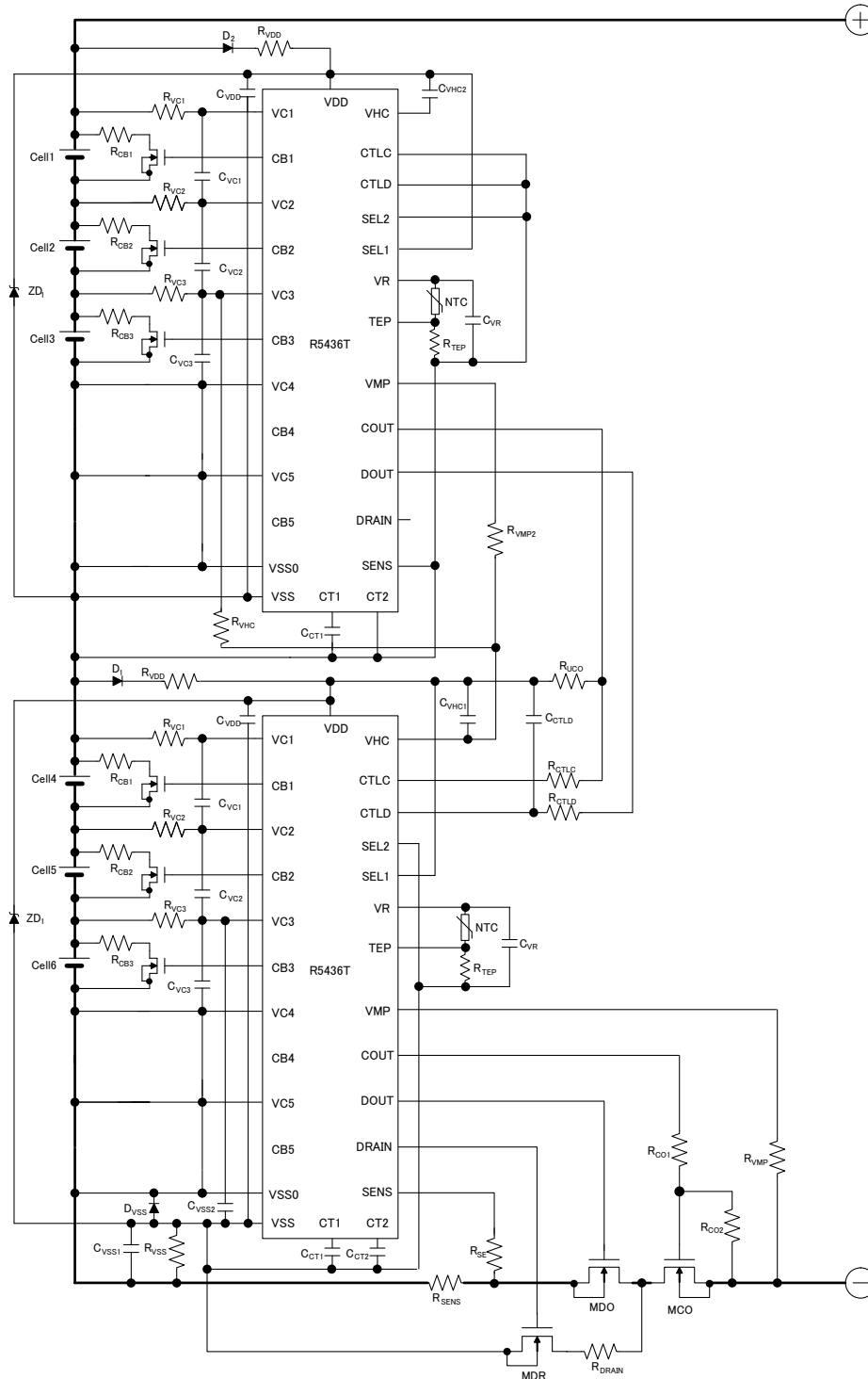

Typical Application Circuit for 6-cell Protection Battery Charger with Cell-balancing Enabled

Typical Application Circuits 6

8-cell Protection Battery Charger with Cell-balancing Enabled

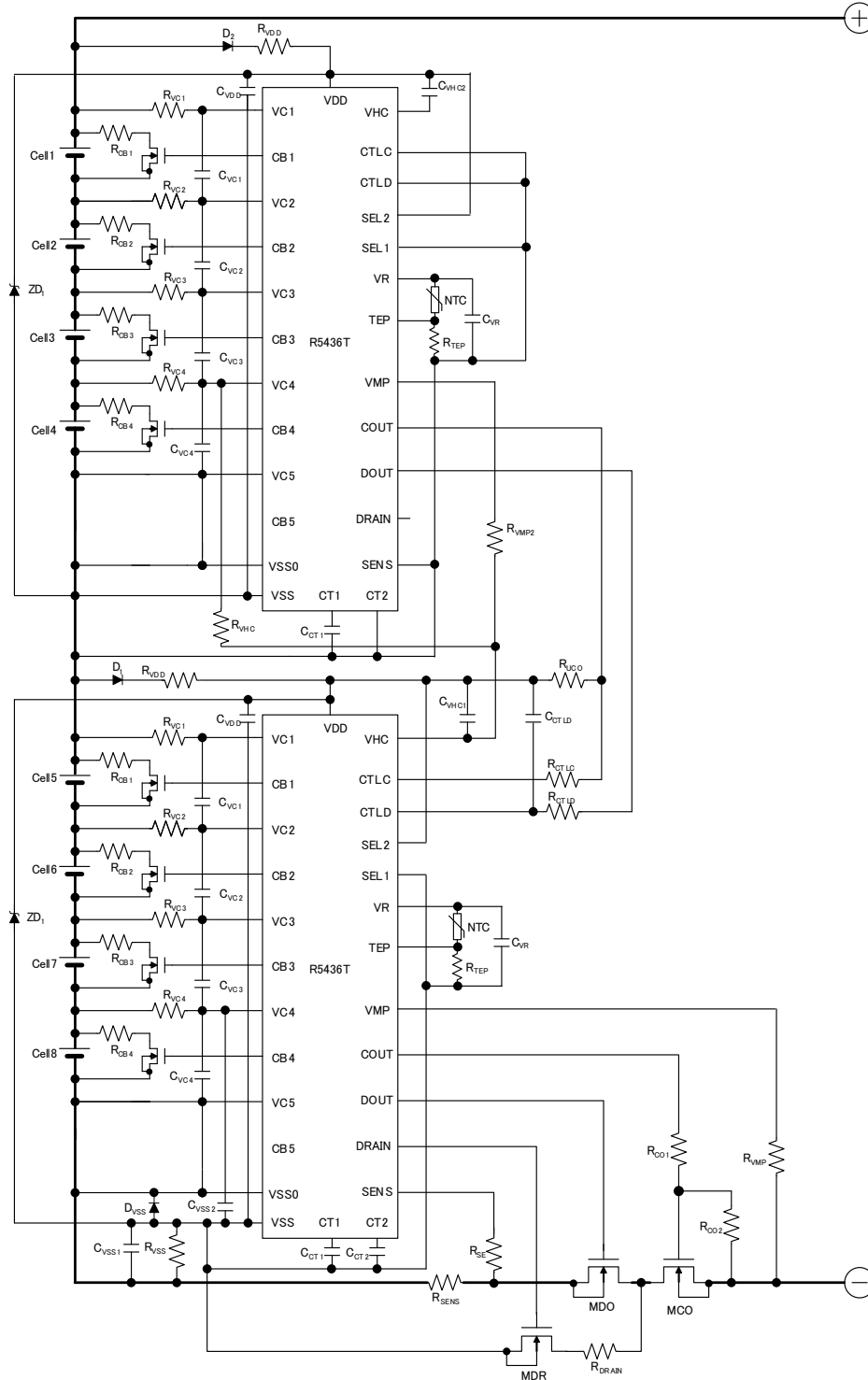

Typical Application Circuit for 8-cell Protection Battery Charger with Cell-balancing Enabled

Typical Application Circuits 7

9-cell Protection Battery Charger with Cell-balancing Enabled

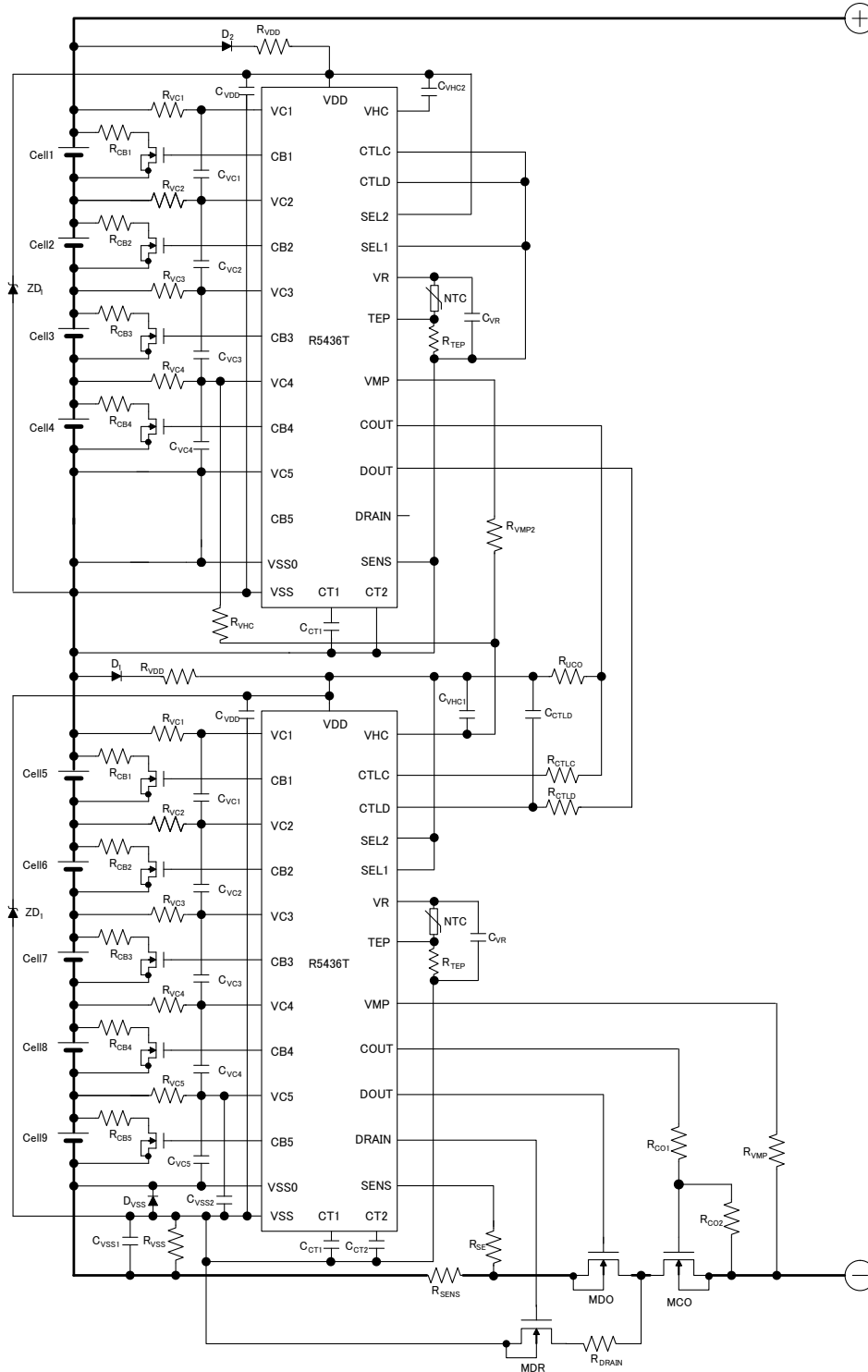

Typical Application Circuit for 9-cell Protection Battery Charger with Cell-balancing Enabled

Typical Application Circuits 8

10-cell Protection Battery Charger with Cell-balancing Enabled

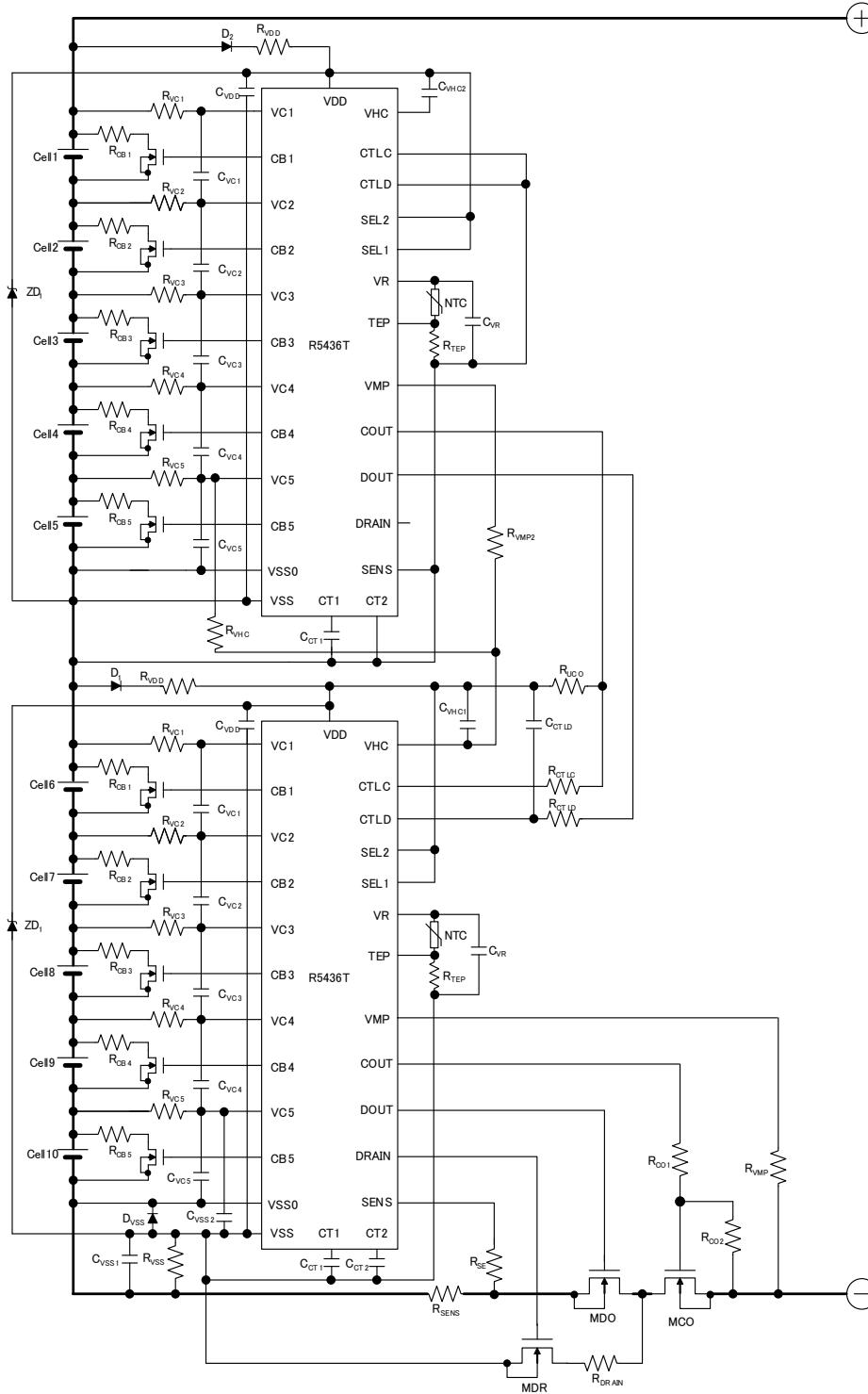

Typical Application Circuit for 10-cell Protection Battery Charger with Cell-balancing Enabled

Typical Application Circuits 12

14-cell Protection Battery Charger with Cell-balancing Enabled (Cascade Connection)

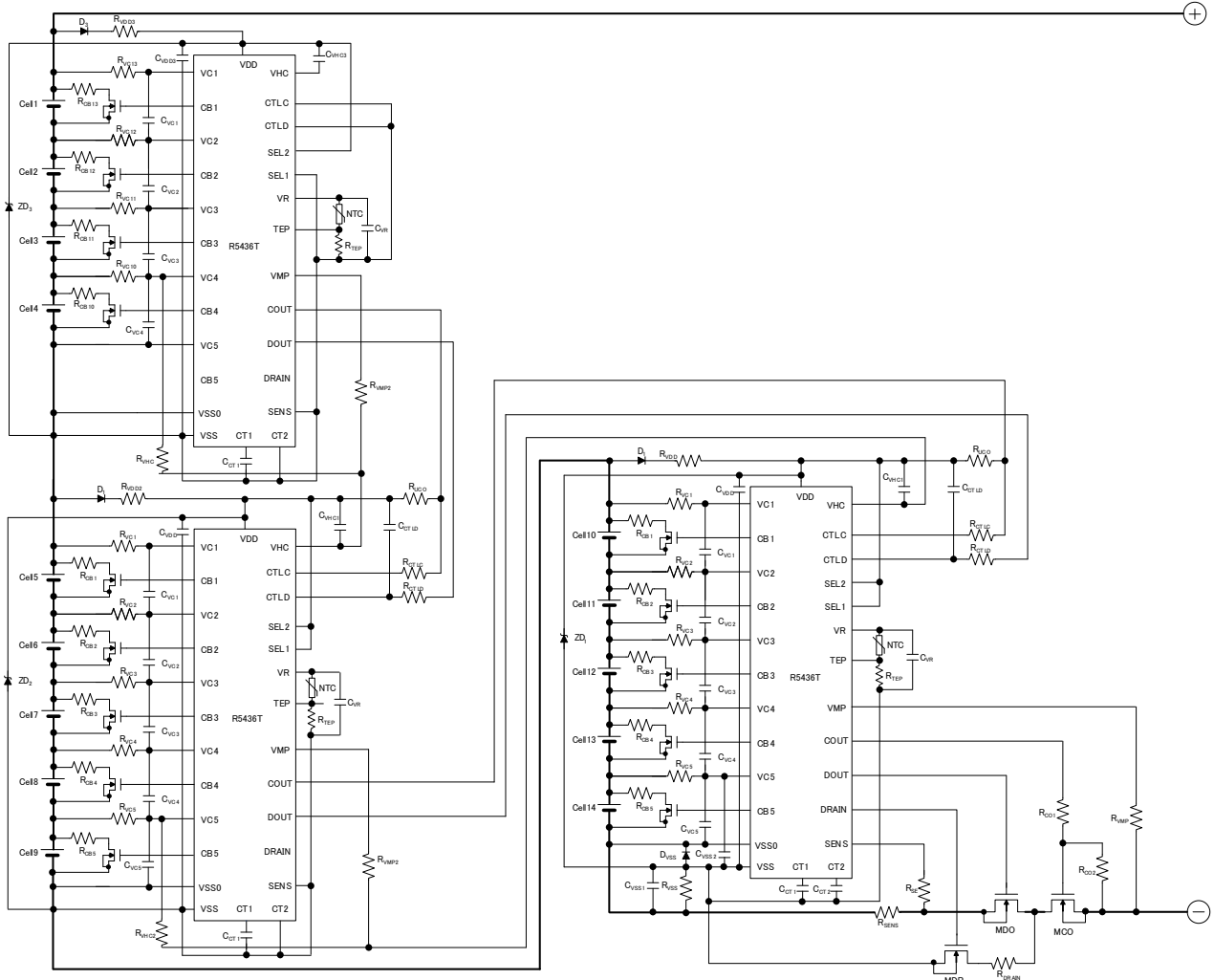

Typical Application Circuit for 14-cell Protection Battery Charger with Cell-balancing Enabled (Cascade Connection)

Typical Application Circuits 13

15-cell Protection Battery Charger with Cell-balancing Enabled (Cascade Connection)

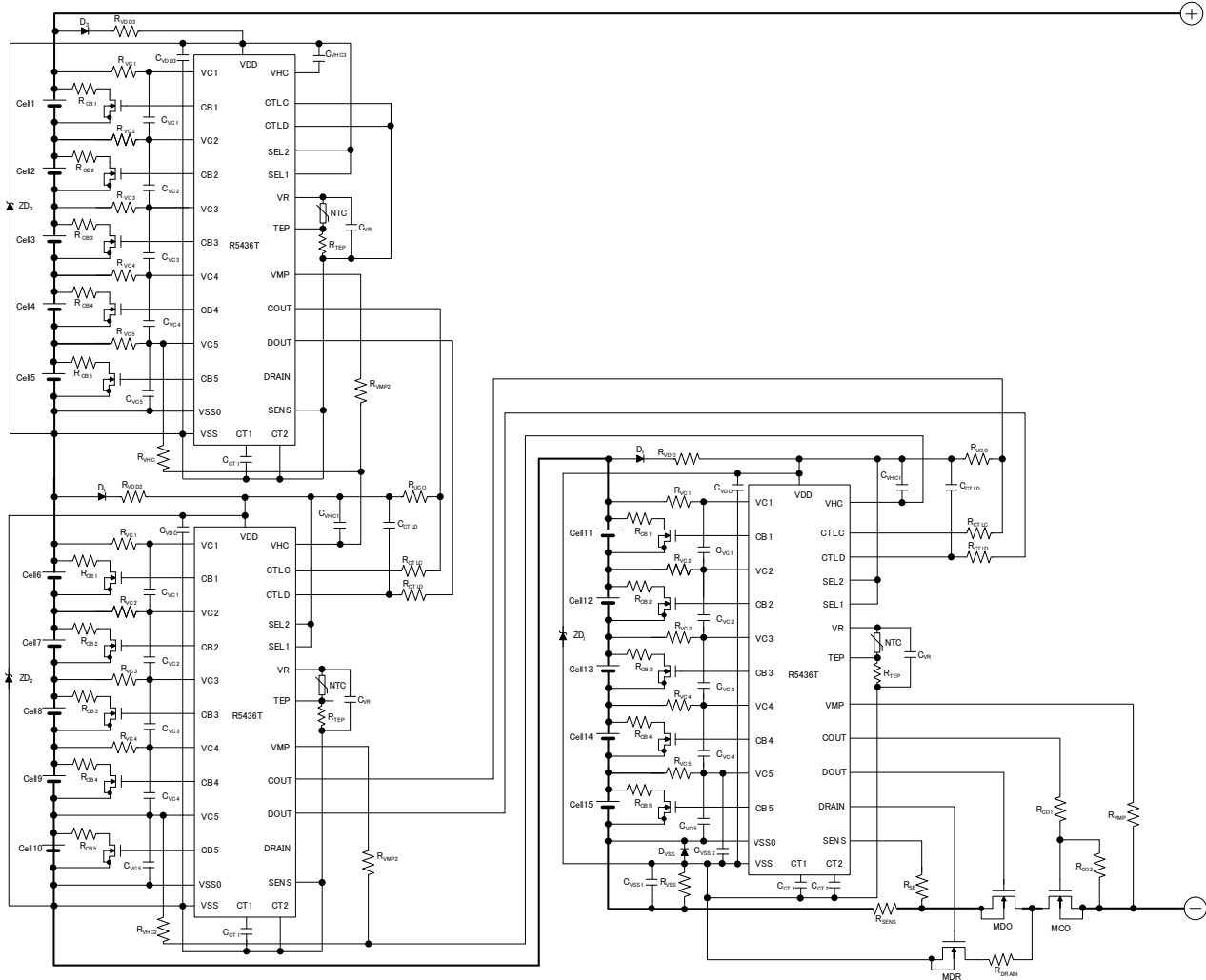

Typical Application Circuit for 15-cell Protection Battery Charger with Cell-balancing Enabled (Cascade Connection)

External Components

Symbol	Value (Typ.)	Range	Unit	Remarks ⁽¹⁾
R _{VDDX}	330	330 to 1000	Ω	Refer to <i>Technical Note [1]</i> .
R _{VC1X}	330	330 to 1000	Ω	Refer to <i>Technical Note [2]</i> .
R _{VC2X}	330	330 to 1000	Ω	
R _{VC3X}	330	330 to 1000	Ω	
R _{VC4X}	330	330 to 1000	Ω	
R _{VC5X}	330	330 to 1000	Ω	
R _{CB1X}	100	Note [3]	Ω	Refer to <i>Technical Note [3]</i> .
R _{CB2X}	100	Note [3]	Ω	
R _{CB3X}	100	Note [3]	Ω	
R _{CB4X}	100	Note [3]	Ω	
R _{CB5X}	100	Note [3]	Ω	
R _{SENS}	100	1 or more	mΩ	Depending on Set Value of Overcurrent
R _{SE}	10	1 to 10	kΩ	Refer to <i>Technical Note [4]</i> .
R _{DRAIN}	75	Note [5]	kΩ	Refer to <i>Technical Note [5]</i> .
R _{CO1}	1	Note [5]	MΩ	
R _{CO2}	2	Note [5]	MΩ	
R _{VMP1}	10	0.01 to 10	MΩ	Refer to <i>Technical Note [6]</i> .
R _{VMP2}	1	1	MΩ	
R _{VMP3}	1	1	MΩ	
R _{CTLX}	1	1 to 10	kΩ	-
R _{CTLD}	10	10 to 100	kΩ	Refer to <i>Technical Note [17]</i> .
R _{UCOX} , R _{UDO}	3	3	MΩ	Refer to <i>Technical Note [7] and [19]</i> .
R _{VSS}	10	10	Ω	Refer to <i>Technical Note [15]</i> .
C _{VSS1}	1	1	μF	
C _{VSS2}	1	0.1 to 1	μF	
C _{VDDX}	1	0.1 to 1	μF	Refer to <i>Technical Note [1]</i> .
C _{VC1X}	0.1	0.1	μF	Refer to <i>Technical Note [2]</i> .
C _{VC2X}	0.1	0.1	μF	
C _{VC3X}	0.1	0.1	μF	
C _{VC4X}	0.1	0.1	μF	
C _{VC5X}	0.1	0.1	μF	
C _{CT1X}	33	10 to 1000	nF	-

⁽¹⁾ Refer to “*Technical Notes for External Components*” for details.

Symbol	Value (Typ.)	Range	Unit	Remarks ⁽¹⁾
C _{CT2X}	3.3	2.2 or more	nF	Refer to <i>Technical Note [8]</i> .
C _{VRX}	1	1	μF	Refer to <i>Technical Note [9]</i> .
C _{CTLD}	33	10 to 100	nF	Refer to <i>Technical Note [17]</i> .
C _{VHCX}	10	3.3 to 10	nF	Refer to <i>Technical Note [18]</i> .
ZD _X	30	30 or less	V	Refer to <i>Technical Note [10]</i> . Recommended Component: MM1Z30_0.5W_30V_J_SOD-123_EIC
R _{VHCX}	5	5 to 10	MΩ	Refer to <i>Technical Note [11]</i> .
R _{TEPX}	350	300 and more	kΩ	Refer to <i>Technical Note [12]</i> . 100 kΩ level at ambient temperature
NTC _X	100	100	kΩ	Refer to <i>Technical Note [12]</i> .
SBD _{VSS}		-	-	Refer to <i>Technical Note [15]</i> . Recommended Component: RB491D_SOT-23
D _X		-	-	Refer to <i>Technical Note [16]</i> . Recommended Component: 1N4148_100mA/100V_4nS_SOT-23
MCO		-	-	Refer to <i>Technical Note [13]</i> .
MDO		-	-	
MDR		-	-	Refer to <i>Technical Note [14]</i> .

Component Selection Guide

- The typical application circuit diagrams are just examples. The operation in application circuits is not guaranteed. Be sure to perform a sufficient evaluation with the external components under the actual usage conditions for selection.
- Be careful not to apply the overvoltage and the overcurrent which exceed the rating to the protection IC and external components. Especially, select an FET with enough current capacity to endure the large current because a large current might flow through the FET during the time between an overcharge detection a blown fuse.

Technical Notes for External Components

【1】 The voltage fluctuation is stabilized with R_{VDD} and C_{VDD}. If a small R_{VDD} is set, in the case of the large transient may happen to the cell voltage, by the flowing current, the IC may be unstable. If a large R_{VDD} is set, by the consumption current of the IC itself, the voltage difference between VDD pin and VC1 pin is generated, and unexpected operation may result. Therefore, the appropriate value range of R_{VDD} is from 330Ω to 1kΩ. To make a stable operation of the IC, the appropriate value range of C_{VDD} is from 0.1μF to 1.0μF.

⁽¹⁾ Refer to “*Technical Notes for External Components*” for details.

- 【2】 R_{VCxx} , C_{VCxx} stabilize the voltage fluctuation. If large R_{VCxx} is set, the detector threshold will be high because of the internal conduction current of the IC. The operation error of open-wire detector function may happen easily by the distribution of the ICs or environment. If small R_{VCxx} is set, the effect by noise will be large. Therefore, the appropriate value range of R_{VCxx} is from 330Ω to $1k\Omega$. To make stable operation, use $0.1\mu F$ as C_{VCxx} .
- 【3】 When the cell balance function is necessary, R_{CBxx} must be chosen carefully with considering the bypass current, and consumption power by the bypass current, and the external MOSFET. Especially, if a small resistance (to set the large bypass current) is set, fully evaluation is necessary. If a large resistance (to set the small bypass current) is set, the time for cell balance will be long.
- 【4】 When the cascade connection is used, if short circuit is happened, by the short current and the R_{SENS} enlarges the voltage, and as a result, if the voltage of SENS pin becomes larger than the VDD of the IC, during the short circuit output delay time, the current flows into SENS pin. Therefore, if a small R_{SE} is set, a large current may flow into SENS pin. If a large R_{SE} is set, the over-current detector threshold may shift. Therefore, the appropriate value is around $10k\Omega$.
- 【5】 Choose appropriate values for R_{DRAIN} , R_{CO1} , and R_{CO2} to satisfy the next equation, otherwise, the release from excess discharge current and short may be impossible.

$$R_{DRAIN} < V_{REL3} \times (R_{CO1} + R_{CO2}) / V_{DD}$$

If small R_{CO1} or R_{CO2} is set, when the output of C_{OUT} is "H", the consumption current of protection circuit board increases. If large R_{CO1} or R_{CO2} is set, when the output of C_{OUT} is "Hi-z", the speed for pull-down the gate of the charge FET becomes slow and turning off the FET will be slow. Dividing between the "Hi-z" output and the resistance might be not enough to turn OFF the charge FET. If a small R_{DRAIN} is set, when the excess discharge current and short circuit is detected, the large current may flow until the load is removed.

- 【6】 When the cascade connection is used, if DOUT turns off, VMP pin is pulled up via R_{VMP} to the top cell. In this case, the current flows via R_{VMP} and the internal diode, therefore, appropriate value must be chosen (usually $M\Omega$ level). If the cascade connection is not used, around $10k\Omega$ is acceptable.
- 【7】 Set R_{UCO} to satisfy $R_{UCO}=R_{CO1}+R_{CO2}$. If an extremely large resistance is set, when the output of C_{OUT} is "Hi-Z", by the dividing resistance, CTLC pin may not be pulled down. If a small resistance is used, when the output of C_{OUT} is "H", the consumption current via R_{UCO} increases.
- 【8】 If a too small C_{CT2} is set, excess discharge current detector output delay time 2 becomes shorter than the short circuit output delay time. Therefore, use a capacitor with $0.0022\mu F$ or more.

- 【9】 To make a stable VR output, it should connect a 1.0 μ F capacitor to VR pin.
- 【10】 Considering the break-down of the resistors and capacitors to stabilize the fluctuation of the voltage, to avoid that the high voltage is directly forced to the IC, adding a zener diode is our recommendation. Connect the zener diode between VDD pin of the IC and VSS pin directly. (Refer to the typical application circuits.) Zener diode MM1Z30_0.5W_30V_J_SOD-123_EIC is recommended.
- 【11】 When the cascade connection is used, the lower side IC can transfer the VMP signal to upper side IC through VHC pin by pulling up VHC pin to the upper side IC's VC5 level through RVHC. The recommended value of RVHC is 5M Ω . If the upper side IC works at 4-cell protection mode, VHC pin should be pulled up to upper side IC's VC4 level. If the upper side IC works at 3-cell protection mode, VHC pin should be pulled up to upper side IC's VC3 level.
- 【12】 The temperature protection function is realized by the voltage divider between a resistor of R_{TEP} and an NTC thermistor. R_{TEP} is equal to 20 times R_{NTC} at the desired protecting temperature. Choose an NTC thermistor with a high resistance capability to reduce the IC consumption current since VR pin cannot supply a large current. Using the high-accuracy thermistor and resistor can be realized more high-accuracy temperature protection.
- 【13】 As for the charge control FET (MCO) and the discharge control FET (MDO), be sure to perform a sufficient consideration of their maximum voltage tolerance, current rating, maximum power consumption and peak consumption when short-circuit.
- 【14】 As for the pull-down FET (MDR), be sure to perform a sufficient consideration to its maximum voltage tolerance.
- 【15】 Schottky Diode (SBD_{VSS}) is required to prevent VSS pin voltage from being larger than VSS0 pin voltage.
- 【16】 Diode (D_x) is required to prevent a drop in the VDD pin voltage (V_{DD}), along with the battery voltage drop.
- 【17】 C_{CTLD} and R_{CTLD} make CTLD pin's transmission stable.
- 【18】 C_{VHC} makes VHC pin signal stable.

TECHNICAL NOTES

A peripheral component or the device mounted on PCB should not exceed a rated voltage, a rated current or a rated power. When designing a peripheral circuit, please be fully aware of the following points.

- Please evaluate the product at the PCB level before use, as some symptoms may remain that cannot be confirmed by the evaluation at the IC level.
- When using any coating or underfill to improve moisture resistance or joining strength, evaluate them adequately before using. In certain materials or coating conditions, corrosion by contained constituents, current leakage by moisture absorption, crack and delamination by physical stress can happen. If the curing temperature of the coating material or underfill material exceeds the absolute maximum rating, the electrical characteristics of this product may change.
- When performing X-ray inspection in mass production process and evaluation build stage such as the product functions and characteristics confirmation, please confirm X-ray irradiation does not exceed 1.5Gy (absorbed dose for air).

The power dissipation of the package is dependent on PCB material, layout, and environmental conditions. The following measurement conditions are based on JEDEC STD.51.

Measurement Conditions

Item	Measurement Conditions
Environment	Mounting on Board (Wind Velocity = 0 m/s)
Board Material	Glass Cloth Epoxy Plastic (Four-Layer Board)
Board Dimensions	76.2 mm × 114.3 mm × 1.6 mm
Copper Ratio	Outer Layers (First and Fourth Layers): Less than 10% of 60 mm Square Inner Layers (Second and Third Layers): 100% of 74.2 mm Square
Through-holes	φ 0.85 mm × 44 pcs

Measurement Result

(Ta = 25°C, Tjmax = 125°C)

	Measurement Result
Power Dissipation	1250 mW
Thermal Resistance	$\theta_{ja} = (125 - 25^\circ\text{C}) / 1.25 \text{ W} = 80^\circ\text{C/W}$ $\theta_{jc} = 25^\circ\text{C/W}$

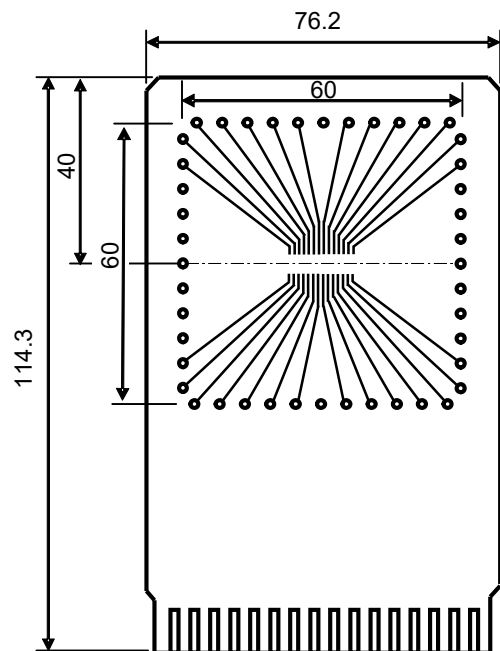
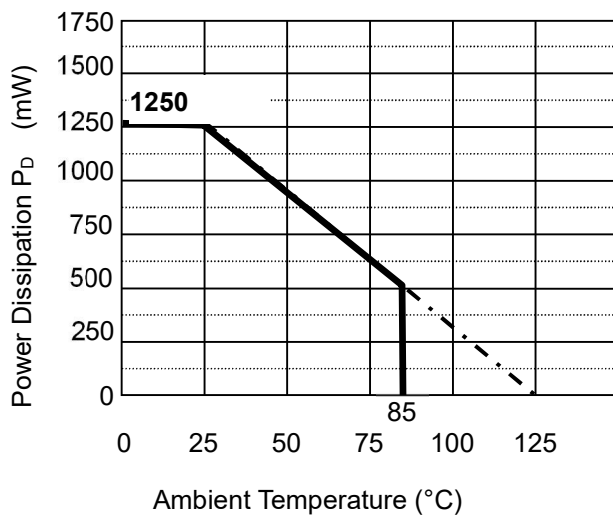

Power Dissipation vs. Ambient Temperature

Measurement Board Pattern

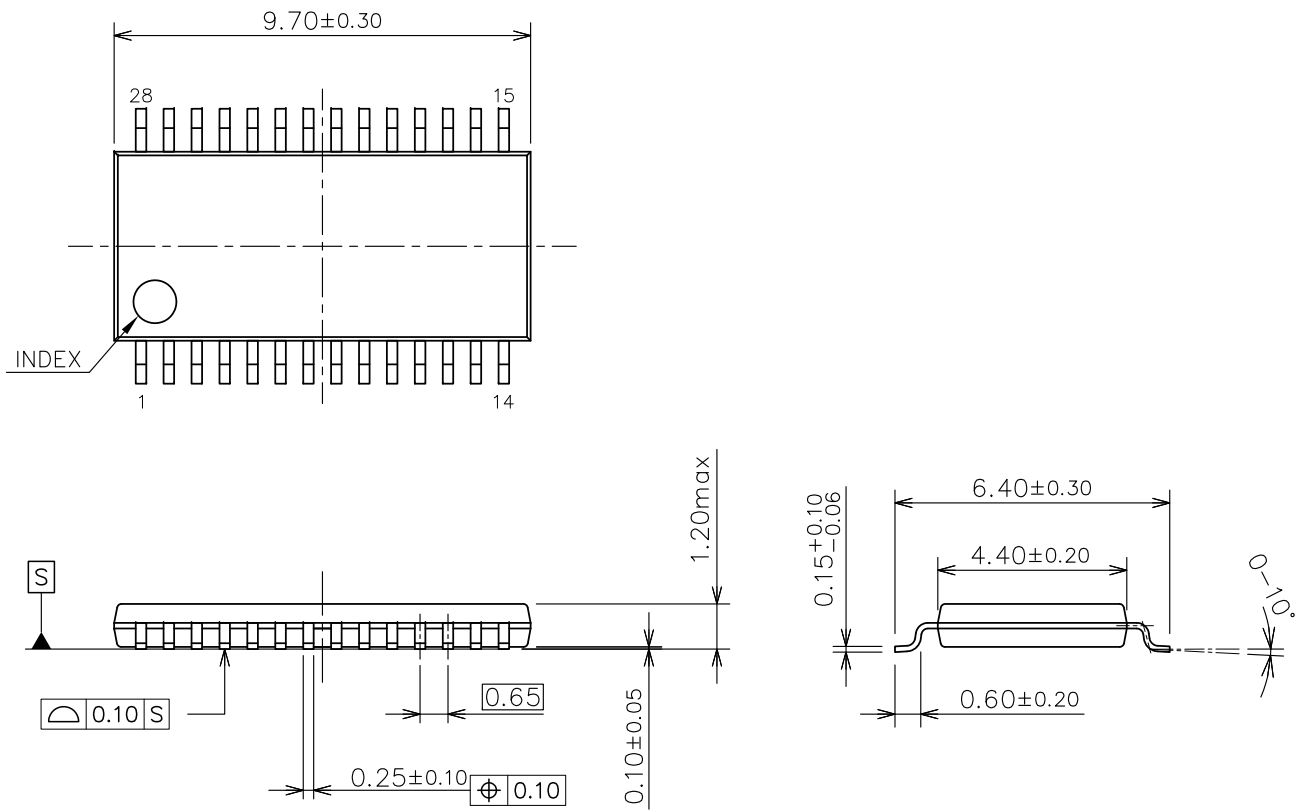

TSSOP-28 Package Dimensions (Unit: mm)

①②③④⑤⑥: Product Code ... Refer to Part Marking List

⑦⑧⑨: Lot Number ... Alphanumeric Serial Number

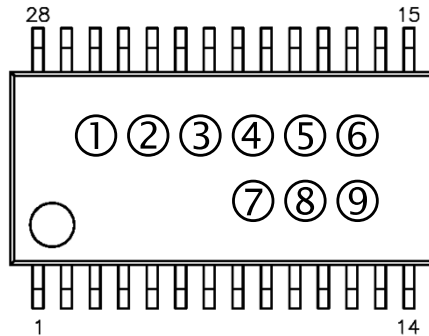

R5436T (TSSOP-28) Part Markings

NOTICE

There can be variation in the marking when different AOI (Automated Optical Inspection) equipment is used. In the case of recognizing the marking characteristic with AOI, please contact our sales or distributor before attempting to use AOI.

R5436T Part Marking List

Product Name	① ② ③ ④ ⑤ ⑥	Product Name	① ② ③ ④ ⑤ ⑥
R5436TxxxBA		R5436TxxxBB	
R5436T502BA	D 5 0 2 B A	R5436T502BB	D 5 0 2 B B
R5436T503BA	D 5 0 3 B A	R5436T503BB	D 5 0 3 B B
R5436T504BA	D 5 0 4 B A	R5436T504BB	D 5 0 4 B B
R5436T505BA	D 5 0 5 B A	R5436T505BB	D 5 0 5 B B
R5436T506BA	D 5 0 6 B A	R5436T506BB	D 5 0 6 B B
R5436T507BA	D 5 0 7 B A	R5436T507BB	D 5 0 7 B B
R5436T508BA	D 5 0 8 B A	R5436T508BB	D 5 0 8 B B
R5436T509BA	D 5 0 9 B A	R5436T511BB	D 5 1 1 B B
R5436T510BA	D 5 1 0 B A	R5436T512BB	D 5 1 2 B B
R5436T511BA	D 5 1 1 B A	R5436T513BB	D 5 1 3 B B
R5436T516BA	D 5 1 6 B A	R5436T514BB	D 5 1 4 B B
R5436T401BA	D 4 0 1 B A	R5436T515BB	D 5 1 5 B B

R5436T Part Marking List (Continued)

Product Name	① ② ③ ④ ⑤ ⑥	Product Name	① ② ③ ④ ⑤ ⑥
R5436TxxxBA		R5436TxxxBB	
		R5436T517BB	D 5 1 7 B B
		R5436T518BB	D 5 1 8 B B
		R5436T519BB	D 5 1 9 B B
		R5436T520BB	D 5 2 0 B B
		R5436T521BB	D 5 2 1 B B
		R5436T522BB	D 5 2 2 B B
		R5436T524BB	D 5 2 4 B B

1. The products and the product specifications described in this document are subject to change or discontinuation of production without notice for reasons such as improvement. Therefore, before deciding to use the products, please refer to our sales representatives for the latest information thereon.
2. The materials in this document may not be copied or otherwise reproduced in whole or in part without the prior written consent of us.
3. This product and any technical information relating thereto are subject to complementary export controls (so-called KNOW controls) under the Foreign Exchange and Foreign Trade Law, and related politics ministerial ordinance of the law. (Note that the complementary export controls are inapplicable to any application-specific products, except rockets and pilotless aircraft, that are insusceptible to design or program changes.) Accordingly, when exporting or carrying abroad this product, follow the Foreign Exchange and Foreign Trade Control Law and its related regulations with respect to the complementary export controls.
4. The technical information described in this document shows typical characteristics and example application circuits for the products. The release of such information is not to be construed as a warranty of or a grant of license under our or any third party's intellectual property rights or any other rights.
5. The products listed in this document are intended and designed for use as general electronic components in standard applications (office equipment, telecommunication equipment, measuring instruments, consumer electronic products, amusement equipment etc.). Those customers intending to use a product in an application requiring extreme quality and reliability, for example, in a highly specific application where the failure or misoperation of the product could result in human injury or death should first contact us.
 - Aerospace Equipment
 - Equipment Used in the Deep Sea
 - Power Generator Control Equipment (nuclear, steam, hydraulic, etc.)
 - Life Maintenance Medical Equipment
 - Fire Alarms / Intruder Detectors
 - Vehicle Control Equipment (automotive, airplane, railroad, ship, etc.)
 - Various Safety Devices
 - Traffic control system
 - Combustion equipment

In case your company desires to use this product for any applications other than general electronic equipment mentioned above, make sure to contact our company in advance. Note that the important requirements mentioned in this section are not applicable to cases where operation requirements such as application conditions are confirmed by our company in writing after consultation with your company.

6. We are making our continuous effort to improve the quality and reliability of our products, but semiconductor products are likely to fail with certain probability. In order to prevent any injury to persons or damages to property resulting from such failure, customers should be careful enough to incorporate safety measures in their design, such as redundancy feature, fire containment feature and fail-safe feature. We do not assume any liability or responsibility for any loss or damage arising from misuse or inappropriate use of the products.
7. The products have been designed and tested to function within controlled environmental conditions. Do not use products under conditions that deviate from methods or applications specified in this datasheet. Failure to employ the products in the proper applications can lead to deterioration, destruction or failure of the products. We shall not be responsible for any bodily injury, fires or accident, property damage or any consequential damages resulting from misuse or misapplication of the products.
8. **Quality Warranty**
 - 8-1. **Quality Warranty Period**

In the case of a product purchased through an authorized distributor or directly from us, the warranty period for this product shall be one (1) year after delivery to your company. For defective products that occurred during this period, we will take the quality warranty measures described in section 8-2. However, if there is an agreement on the warranty period in the basic transaction agreement, quality assurance agreement, delivery specifications, etc., it shall be followed.
 - 8-2. **Quality Warranty Remedies**

When it has been proved defective due to manufacturing factors as a result of defect analysis by us, we will either deliver a substitute for the defective product or refund the purchase price of the defective product.

Note that such delivery or refund is sole and exclusive remedies to your company for the defective product.
 - 8-3. **Remedies after Quality Warranty Period**

With respect to any defect of this product found after the quality warranty period, the defect will be analyzed by us. On the basis of the defect analysis results, the scope and amounts of damage shall be determined by mutual agreement of both parties. Then we will deal with upper limit in Section 8-2. This provision is not intended to limit any legal rights of your company.
9. Anti-radiation design is not implemented in the products described in this document.
10. The X-ray exposure can influence functions and characteristics of the products. Confirm the product functions and characteristics in the evaluation stage.
11. WLCSP products should be used in light shielded environments. The light exposure can influence functions and characteristics of the products under operation or storage.
12. Warning for handling Gallium and Arsenic (GaAs) products (Applying to GaAs MMIC, Photo Reflector). These products use Gallium (Ga) and Arsenic (As) which are specified as poisonous chemicals by law. For the prevention of a hazard, do not burn, destroy, or process chemically to make them as gas or power. When the product is disposed of, please follow the related regulation and do not mix this with general industrial waste or household waste.
13. Please contact our sales representatives should you have any questions or comments concerning the products or the technical information.



Nisshinbo Micro Devices Inc.

Official website

<https://www.nisshinbo-microdevices.co.jp/en/>

Purchase information

<https://www.nisshinbo-microdevices.co.jp/en/buy/>