

Microprocessor Supervisory Circuit with Manual Reset for Automotive Applications

NO.EC-170-220131

OUTLINE

The R5107G is a microprocessor supervisory circuit and has high accuracy and ultra low supply current voltage detector with built-in delay circuit and watchdog timer. When the supply voltage is down across the threshold, or the watchdog timer does not detect the system clock from the microprocessor, the reset output is generated. The voltage detector circuit is used for the system reset, etc. The detector threshold is fixed internally, and the accuracy is $\pm 1.0\%$. The released delay time (Power-on Reset Delay) circuit is built-in, and output delay time is adjustable with an external capacitor, and the accuracy is $\pm 16\%$ (R5107Gxx1x-TR-JE: $-40^{\circ}\text{C} \leq T_a \leq 105^{\circ}\text{C}$)⁽¹⁾. When the supply voltage becomes the released voltage, the reset state will be maintained during the delay time. The output type of the reset is selectable, Nch open-drain, or CMOS.

The time out period of the watchdog timer can be also set with an external capacitor, and the accuracy is $\pm 33\%$ ⁽¹⁾.

The function to stop supervising clock by the watchdog timer (INH function) and manual reset function are built in this IC. There are another 4 products by the difference of packages and the function of voltage detector and watchdog timer. The package of R5107G is SSOP-8G.

FEATURES

- Operating Voltage Range (Maximum Rating) 0.9V to 6.0V (7.0V)
- Supply Current Typ. 11 μ A

< Voltage Detector Part >

- Detector Threshold Range 1.5V to 5.5V (0.1V steps)
- Detector Threshold Accuracy $\pm 1.0\%$
- Detector Threshold Temperature Coefficient Typ. ± 100 ppm/ $^{\circ}\text{C}$
R5107Gxx1x-TR-AE: $-40^{\circ}\text{C} \leq T_a \leq 125^{\circ}\text{C}$
R5107Gxx1x-TR-JE: $-40^{\circ}\text{C} \leq T_a \leq 105^{\circ}\text{C}$
- Power-on Reset Delay Time accuracy⁽¹⁾ $\pm 18\%$ (R5107Gxx1x-TR-AE: $-40^{\circ}\text{C} \leq T_a \leq 125^{\circ}\text{C}$)
 $\pm 16\%$ (R5107Gxx1x-TR-JE: $-40^{\circ}\text{C} \leq T_a \leq 105^{\circ}\text{C}$)
- Power-on reset delay time of the voltage detector Typ. 370ms with an external capacitor : 0.1 μ F
- With Manual Reset pin (MR) Able to reset voltage detector and watchdog timer

< Watchdog Timer Part >

- Built-in a watchdog timer's time out period accuracy⁽¹⁾ $\pm 33\%$
R5107Gxx1x-TR-AE: $-40^{\circ}\text{C} \leq T_a \leq 125^{\circ}\text{C}$
R5107Gxx1x-TR-JE: $-40^{\circ}\text{C} \leq T_a \leq 105^{\circ}\text{C}$
- Timeout period for watchdog timer Typ. 310ms with an external capacitor : 0.1 μ F
- Reset timer for watchdog timer Typ. 34ms with an external capacitor : 0.1 μ F
- With Inhibit pin (INH) Able to stop watchdog timer
- Package SSOP-8G

APPLICATIONS

- Voltage monitoring for electronic control units such as EV inverter and battery charge control unit.

SELECTION GUIDE

The detector threshold, the output type and the taping type for the ICs can be selected at the users' request. The selection can be made with designating the part number as shown below;

Product Name	Package	Quantity per Reel	Pb Free	Halogen Free
R5107Gxx1*-TR-#E	SSOP-8G	3,000 pcs	Yes	Yes

xx: The detector threshold ($-V_{DET}$) can be designated in the range from 1.5V(15) to 5.5V(55) in 0.1V steps.

* : Designation of Output Type
(A) Nch Open Drain
(C) CMOS

: Quality Class

	Operating Temperature Range	Test Temp.
A	-40°C to 125°C	25°C, High
J	-40°C to 105°C	Low, 25°C, High

Series Selection

	R5105N	R5106N	R5107G	R5108G	R5109G
Package	SOT-23-6		SSOP-8G		
With INH pin (Inhibit)	No	Yes			
2 clock input	No				Yes
With MR pin (Manual Reset)	No		Yes	No	
With SENSE pin	No			Yes	No
Remarks		C_D pin and C_{TW} pin are combined uses.		Operating Voltage Range 1.5V to 6.0V	Supply Current 11.5 μ A

BLOCK DIAGRAMS

R5107Gxx1A
(Nch Open Drain Output)

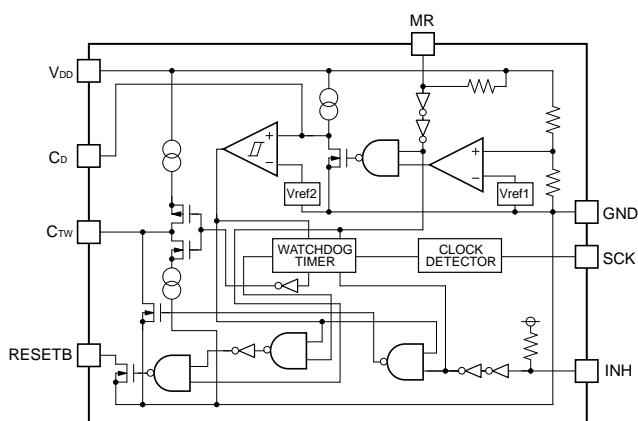

R5107Gxx1C
(CMOS Output)

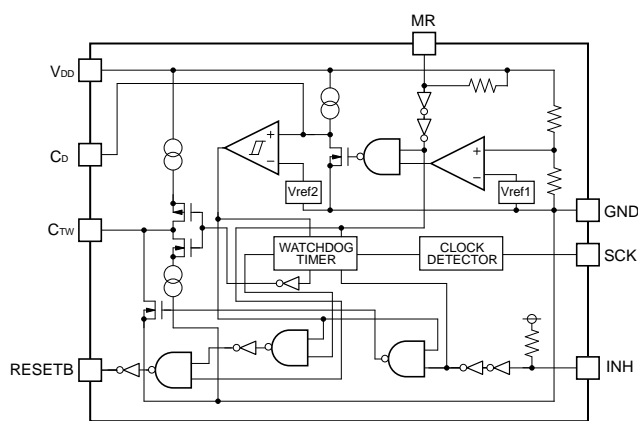

PIN DESCRIPTIONS

● SSOP-8G

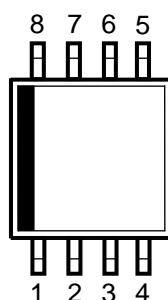

Pin No.	Symbol	Description
1	RESETB	Output Pin for Reset signal of Watchdog timer and Voltage Detector. (Output "L" at detecting Detector Threshold and Watchdog Timer Reset.)
2	MR	Manual Reset Pin (Active"L")
3	C _D	External Capacitor Pin for Setting Delay Time of Voltage Detector
4	GND	Ground Pin
5	SCK	Clock Input Pin from Microprocessor
6	INH	Inhibit Pin ("L": Inhibit the watchdog timer)
7	C _{TW}	External Capacitor Pin for Setting Reset and Watchdog Timeout Periods
8	V _{DD}	Power supply Pin

ABSOLUTE MAXIMUM RATINGS

(Ta=25°C)

Symbol	Item	Rating	Unit
V _{DD}	Supply Voltage	-0.3 to 7.0	V
V _{CD}	Output Voltage	Voltage of C _D Pin	-0.3 to V _{DD} + 0.3
V _{CTW}		Voltage of C _{TW} Pin	-0.3 to V _{DD} + 0.3
V _{RESETB}		Voltage of RESETB Pin	-0.3 to 7.0
V _{SCK}	Input Voltage	Voltage of SCK Pin	-0.3 to 7.0
V _{INH}		Voltage of INH Pin	-0.3 to 7.0
V _{MR}		Voltage of MR Pin	-0.3 to 7.0
I _{RESETB}	Output Current	Current of RESETB Pin	20
P _D	Power Dissipation ⁽¹⁾ (SSOP-8G, Standard Test Land Pattern)		475
T _j	Junction Temperature	-40 to 150	°C
T _{stg}	Storage Temperature Range	-55 to 150	°C

ABSOLUTE MAXIMUM RATINGS

Electronic and mechanical stress momentarily exceeded absolute maximum ratings may cause permanent damage and may degrade the life time and safety for both device and system using the device in the field. The functional operation at or over these absolute maximum ratings are not assured.

RECOMMENDED OPERATING CONDITIONS

Symbol	Item	Rating	Unit
V _{DD}	Operating Voltage	0.9 to 6.0	V
T _a	Operating Temperature Range	R5107Gxx1x-TR-AE	-40 to 125
		R5107Gxx1x-TR-JE	-40 to 105

RECOMMENDED OPERATING CONDITIONS

All of electronic equipment should be designed that the mounted semiconductor devices operate within the recommended operating conditions. The semiconductor devices cannot operate normally over the recommended operating conditions, even if they are used over such ratings by momentary electronic noise or surge. And the semiconductor devices may receive serious damage when they continue to operate over the recommended operating conditions.

⁽¹⁾ Refer to *POWER DISSIPATION* for detailed information.

ELECTRICAL CHARACTERISTICS

VDD=6.0V, CTW=0.1μF, CD=0.1μF, In case of Nch Open Drain Output type, the output pin is pulled up with a resistance of 100kΩ (R5107Gxx1A), unless otherwise noted.

The specification in is checked and guaranteed by design engineering at $-40^{\circ}\text{C} \leq T_a \leq 125^{\circ}\text{C}$.

R5107Gxx1A/C-TR-AE

(Ta=25°C)

Symbol	Item	Conditions	Min.	Typ.	Max.	Unit
I _{SS}	Supply Current	V _{DD} = -V _{DET} +0.5V, Clock pulse input		11	15	μA

VD Part

Symbol	Item	Conditions	Min.	Typ.	Max.	Unit
-V _{DET}	Detector Threshold	T _a =25°C	×0.990		×1.010	V
		-40°C ≤ T _a ≤ 125°C	×0.972		×1.015	
V _{HYS}	Detector Threshold Hysteresis		$\frac{-V_{DET}}{\times 0.03}$	$\frac{-V_{DET}}{\times 0.05}$	$\frac{-V_{DET}}{\times 0.07}$	V
t _{PLH}	Output Delay Time	C _D =0.1μF ⁽¹⁾	340	370	485	ms
I _{RESETB}	Output Current (RESETB Output pin)	Nch V _{DD} =1.2V, V _{DS} =0.1V	0.36	0.8		mA
		Pch ⁽²⁾ V _{DD} =6.0V, V _{DS} =0.5V	0.63	0.9		mA
V _{MRH}	MR Input "H" ⁽³⁾		1.0		6.0	V
V _{MRL}	MR Input "L"		0		0.35	V
t _{MRW}	MR Input Pulse Width ⁽⁴⁾		3			μs
R _{MR}	MR Pull-up Resistance		60	110	164	kΩ

WDT Part

Symbol	Item	Conditions	Min.	Typ.	Max.	Unit
t _{WD}	Watchdog Timeout period	C _{TW} =0.1μF ⁽¹⁾	230	310	450	ms
t _{WR}	Reset Hold Time of WDT	C _{TW} =0.1μF ⁽¹⁾	29	34	48	ms
V _{SCKH}	SCK Input "H"		$V_{DD} \times 0.8$		6.0	V
V _{SCKL}	SCK Input "L"		0		$V_{DD} \times 0.2$	V
V _{INHH}	INH Input "H"		1.0		6.0	V
V _{INHL}	INH Input "L"		0		0.35	V
R _{INH}	INH pull-up Resistance		64	110	152	kΩ
t _{SCKW}	SCK Input Pulse Width	V _{SCKL} =V _{DD} ×0.2, V _{SCKH} =V _{DD} ×0.8	500			ns

On all of unit, all items except MR Input Pulse Width in the above are tested and specified under load conditions such that T_j≈T_a=25°C.

⁽¹⁾ The specification does not contain the temperature characteristics of the external capacitor.

⁽²⁾ In case of CMOS type (R5107Gxx1C)

⁽³⁾ In case of CMOS type (R5107Gxx1C)

⁽⁴⁾ MR input pulse width specification guarantee the minimum input pulse width of MR pin for output "L" from RESETB pin. If the "L" pulse width of MR is short, t_{PLH} may be short. Refer to the timing diagram for details.

VDD=6.0V, CTW=0.1μF, CD=0.1μF, In case of Nch Open Drain Output type, the output pin is pulled up with a resistance of 100kΩ (R5107Gxx1A), unless otherwise noted.

The specification in is checked and guaranteed by design engineering at $-40^{\circ}\text{C} \leq T_a \leq 105^{\circ}\text{C}$.

R5107Gxx1A/C-TR-JE

(Ta=25°C)

Symbol	Item	Conditions	Min.	Typ.	Max.	Unit
I _{SS}	Supply Current	V _{DD} = -V _{DET} +0.5V, Clock pulse input		11	15	μA

VD Part

Symbol	Item	Conditions	Min.	Typ.	Max.	Unit
-V _{DET}	Detector Threshold	Ta=25°C	×0.990		×1.010	V
		-40°C ≤ Ta ≤ 105°C	×0.972		×1.015	
V _{HYS}	Detector Threshold Hysteresis		-V _{DET} ×0.03	-V _{DET} ×0.05	-V _{DET} ×0.07	V
t _{PLH}	Output Delay Time	C _D =0.1μF ⁽¹⁾	340	370	467	ms
I _{RESETB}	Output Current (RESETB Output pin)	Nch V _{DD} =1.2V, V _{DS} =0.1V	0.38	0.8		mA
		Pch ⁽²⁾ V _{DD} =6.0V, V _{DS} =0.5V	0.65	0.9		mA
V _{MRH}	MR Input "H" ⁽³⁾		1.0		6.0	V
V _{MRL}	MR Input "L"		0		0.35	V
t _{MRW}	MR Input Pulse Width ⁽⁴⁾		3			μs
R _{MR}	MR Pull-up Resistance		60	110	164	kΩ

WDT Part

Symbol	Item	Conditions	Min.	Typ.	Max.	Unit
t _{WD}	Watchdog Timeout period	C _{TW} =0.1μF ⁽¹⁾	230	310	450	ms
t _{WR}	Reset Hold Time of WDT	C _{TW} =0.1μF ⁽¹⁾	29	34	48	ms
V _{SCKH}	SCK Input "H"		V _{DD} ×0.8		6.0	V
V _{SCKL}	SCK Input "L"		0		V _{DD} ×0.2	V
V _{INH}	INH Input "H"		1.0		6.0	V
V _{INHL}	INH Input "L"		0		0.35	V
R _{INH}	INH pull-up Resistance		64	110	152	kΩ
t _{SCKW}	SCK Input Pulse Width	V _{SCKL} =V _{DD} ×0.2, V _{SCKH} =V _{DD} ×0.8	500			ns

On all of unit, all items except MR Input Pulse Width in the above are tested and specified under load conditions such that T_j≈T_a=25°C.

(1) The specification does not contain the temperature characteristics of the external capacitor.

(2) In case of CMOS type (R5107Gxx1C)

(3) In case of CMOS type (R5107Gxx1C)

(4) MR input pulse width specification guarantee the minimum input pulse width of MR pin for output "L" from RESETB pin. If the "L" pulse width of MR is short, t_{PLH} may be short. Refer to the timing diagram for details.

Product-specific Electrical Characteristics

Product Name	-V _{DET}						V _{HYS}		
	Ta = 25°C			-40°C ≤ Ta ≤ 125 °C/ -40°C ≤ Ta ≤ 105 °C			Min.	Typ.	Max.
	Min.	Typ.	Max.	Min.	Typ.	Max.			
R5107G151x	1.485	1.500	1.515	1.4580	1.500	1.5225	0.045	0.075	0.105
R5107G161x	1.584	1.600	1.616	1.5552	1.600	1.6240	0.048	0.080	0.112
R5107G171x	1.683	1.700	1.717	1.6524	1.700	1.7255	0.051	0.085	0.119
R5107G181x	1.782	1.800	1.818	1.7496	1.800	1.8270	0.054	0.090	0.126
R5107G191x	1.881	1.900	1.919	1.8468	1.900	1.9285	0.057	0.095	0.133
R5107G201x	1.980	2.000	2.020	1.9440	2.000	2.0300	0.060	0.100	0.140
R5107G211x	2.079	2.100	2.121	2.0412	2.100	2.1315	0.063	0.105	0.147
R5107G221x	2.178	2.200	2.222	2.1384	2.200	2.2330	0.066	0.110	0.154
R5107G231x	2.277	2.300	2.323	2.2356	2.300	2.3345	0.069	0.115	0.161
R5107G241x	2.376	2.400	2.424	2.3328	2.400	2.4360	0.072	0.120	0.168
R5107G251x	2.475	2.500	2.525	2.4300	2.500	2.5375	0.075	0.125	0.175
R5107G261x	2.574	2.600	2.626	2.5272	2.600	2.6390	0.078	0.130	0.182
R5107G271x	2.673	2.700	2.727	2.6244	2.700	2.7405	0.081	0.135	0.189
R5107G281x	2.772	2.800	2.828	2.7216	2.800	2.8420	0.084	0.140	0.196
R5107G291x	2.871	2.900	2.929	2.8188	2.900	2.9435	0.087	0.145	0.203
R5107G301x	2.970	3.000	3.030	2.9160	3.000	3.0450	0.090	0.150	0.210
R5107G311x	3.069	3.100	3.131	3.0132	3.100	3.1465	0.093	0.155	0.217
R5107G321x	3.168	3.200	3.232	3.1104	3.200	3.2480	0.096	0.160	0.224
R5107G331x	3.267	3.300	3.333	3.2076	3.300	3.3495	0.099	0.165	0.231
R5107G341x	3.366	3.400	3.434	3.3048	3.400	3.4510	0.102	0.170	0.238
R5107G351x	3.465	3.500	3.535	3.4020	3.500	3.5525	0.105	0.175	0.245
R5107G361x	3.564	3.600	3.636	3.4992	3.600	3.6540	0.108	0.180	0.252
R5107G371x	3.663	3.700	3.737	3.5964	3.700	3.7555	0.111	0.185	0.259
R5107G381x	3.762	3.800	3.838	3.6936	3.800	3.8570	0.114	0.190	0.266
R5107G391x	3.861	3.900	3.939	3.7908	3.900	3.9585	0.117	0.195	0.273
R5107G401x	3.960	4.000	4.040	3.8880	4.000	4.0600	0.120	0.200	0.280
R5107G411x	4.059	4.100	4.141	3.9852	4.100	4.1615	0.123	0.205	0.287
R5107G421x	4.158	4.200	4.242	4.0824	4.200	4.2630	0.126	0.210	0.294
R5107G431x	4.257	4.300	4.343	4.1796	4.300	4.3645	0.129	0.215	0.301
R5107G441x	4.356	4.400	4.444	4.2768	4.400	4.4660	0.132	0.220	0.308
R5107G451x	4.455	4.500	4.545	4.3740	4.500	4.5675	0.135	0.225	0.315
R5107G461x	4.554	4.600	4.646	4.4712	4.600	4.6690	0.138	0.230	0.322
R5107G471x	4.653	4.700	4.747	4.5684	4.700	4.7705	0.141	0.235	0.329
R5107G481x	4.752	4.800	4.848	4.6656	4.800	4.8720	0.144	0.240	0.336
R5107G491x	4.851	4.900	4.949	4.7628	4.900	4.9735	0.147	0.245	0.343
R5107G501x	4.950	5.000	5.050	4.8600	5.000	5.0750	0.150	0.250	0.350
R5107G511x	5.049	5.100	5.151	4.9572	5.100	5.1765	0.153	0.255	0.357
R5107G521x	5.148	5.200	5.252	5.0544	5.200	5.2780	0.156	0.260	0.364
R5107G531x	5.247	5.300	5.353	5.1516	5.300	5.3795	0.159	0.265	0.371
R5107G541x	5.346	5.400	5.454	5.2488	5.400	5.4810	0.162	0.270	0.378
R5107G551x	5.445	5.500	5.555	5.3460	5.500	5.5825	0.165	0.275	0.385

THEORY OF OPERATION

TIMING CHART

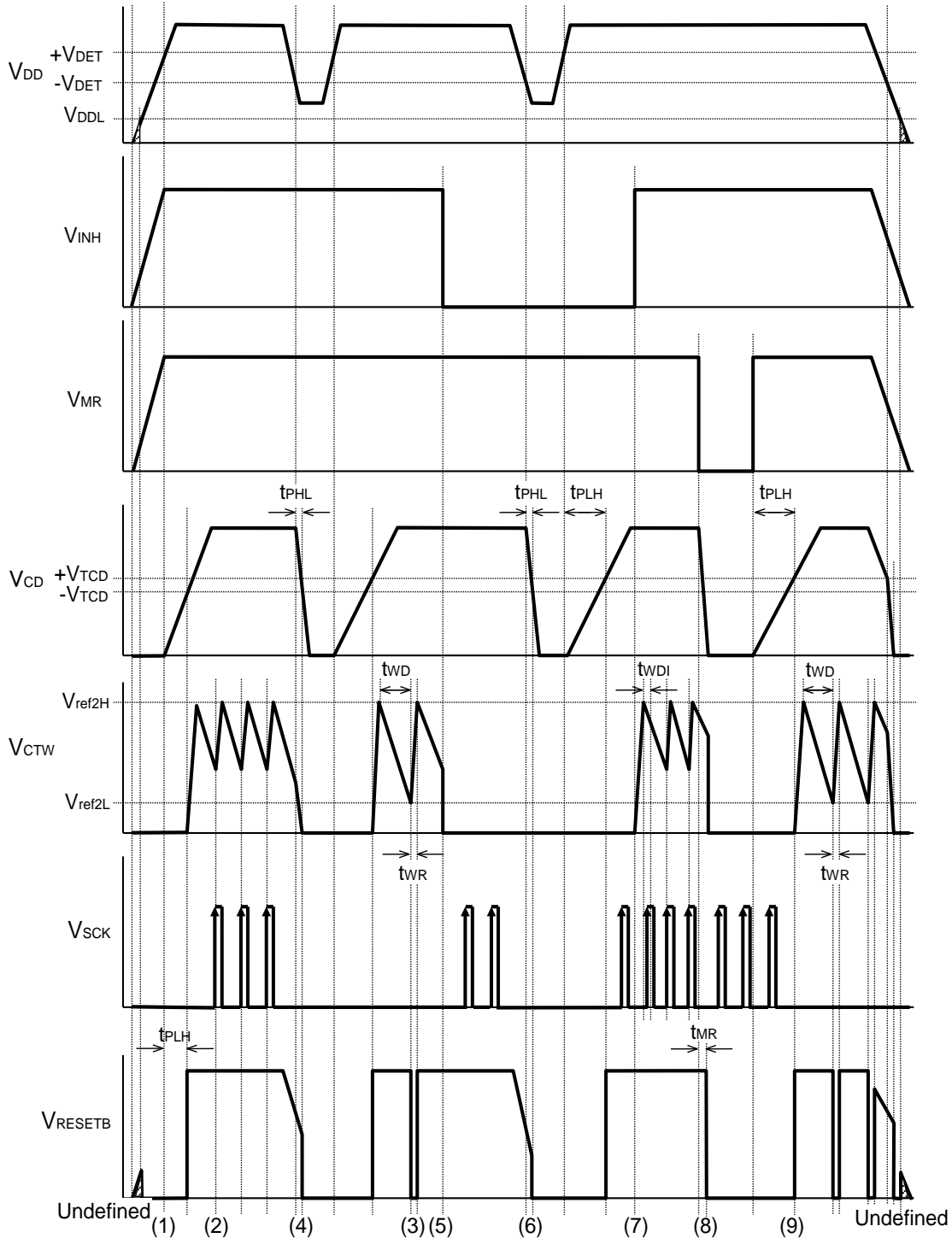

- *) V_{TCD} : Threshold voltage of C_D pin when a power-on reset pulse inverting.
- *) V_{ref2H} : C_{TW} pin voltage at the end of WDT timeout period.
- *) V_{ref2L} : C_{TW} pin voltage at the begin of WDT timeout period.
- *) V_{DDL} : 0.9 V (Max.)

Operating Description

- (1) When the power supply, V_{DD} pin voltage becomes more than the released voltage ($+V_{DET}$), after the released delay time (or the power on reset time t_{PLH}), the output of RESETB becomes "H" level.
- (2) When the SCK pulse is input, the watchdog timer is cleared, and C_{TW} pin mode changes from the discharge mode to the charge mode. When the C_{TW} pin voltage becomes higher than V_{ref2H} , the mode will change into the discharge mode, and next watchdog time count starts.
- (3) Unless the SCK pulse is input, WDT will not be cleared, and during the charging period of C_{TW} pin, RESETB="L".
- (4) When the V_{DD} pin becomes lower than the detector threshold voltage ($-V_{DET}$), RESETB outputs "L" after the t_{PHL} .
- (5) If "L" signal is input to the INH pin, the RESETB outputs "H", regardless the SCK clock state.
- (6) During the "L" period of INH pin, the voltage detector monitors the supply voltage.
- (7) When the signal to the INH pin is set from "L" to "H", the watchdog starts supervising the system clock, or charge cycle to the C_{TW} pin starts, the capacitor connected to the C_{TW} pin is charged with the current of setting Reset time of WDT.
- (8) If "L" signal is input to the MR pin, the RESETB outputs "L" after the t_{MR} , regardless the SCK clock state and V_{DD} voltage.
- (9) When the signal to the MR pin is set from "L" to "H", the RESETB outputs "H" after the t_{PLH} , the watchdog starts supervising the system clock.

Watchdog Timeout period/Reset hold time

The watchdog timeout period and reset hold time can be set with an external capacitor to C_{TW} pin.

The next equations describe the relation between the watchdog timeout period and the external capacitor value, or the reset hold time and the external capacitor value.

$$t_{WD} (s) = 3.1 \times 10^6 \times C (F)$$

$$t_{WR} (s) = t_{WD}/9$$

The watchdog timer (WDT) timeout period is determined with the discharge time of the external capacitor.

During the watchdog timeout period, if the clock pulse from the system is detected, WDT is cleared and the capacitor is charged. When the charge of the capacitor completes, another watchdog timeout period starts again. During the watchdog timeout period, if the clock pulse from the system is not detected, during the next reset hold time RESETB pin outputs "L".

During the reset time, (while charging the external capacitor) and after starting the watchdog timeout period, (just after from the discharge of the external capacitor) even if the clock pulse is input during the time period " t_{WDI} ", the clock pulse is ignored.

$$t_{WDI} (s) = t_{WD}/10$$

Released Delay Time (Power-on Reset delay time)

The released delay time can be set with an external capacitor connected to the C_D pin. The next equation describes the relation between the capacitance value and the released delay time (t_{PLH}).

$$t_{PLH}(s) = 3.7 \times 10^6 \times C (F)$$

The capacitor connected to C_D pin determines t_{WD} , t_{WR} , and t_{PLH} .

When the V_{DD} voltage becomes equal or less than ($-V_{DET}$), discharge of the capacitor connected to the C_D pin starts. Therefore, if the discharge is not enough and V_{DD} voltage returns to ($+V_{DET}$) or more, thereafter the delay time will be shorter than t_{PLH} which is expected.

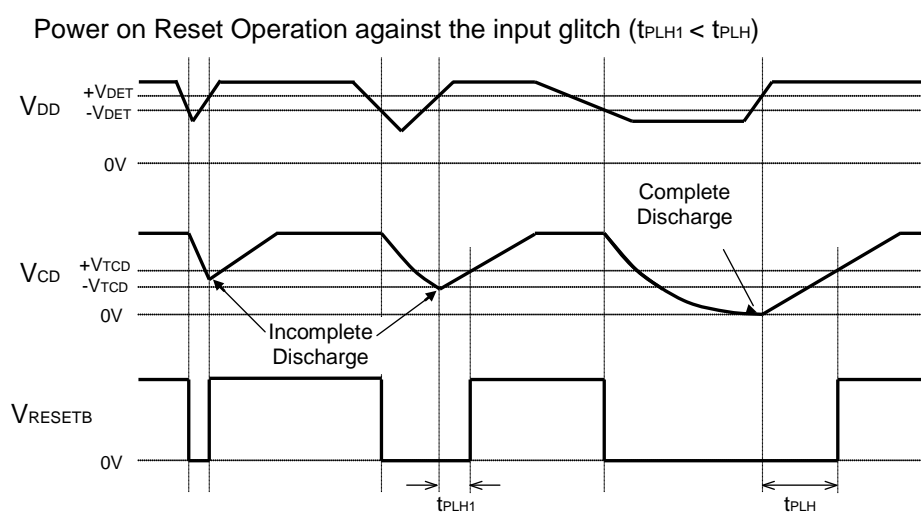

Minimum Operating Voltage

We specified the minimum operating voltage as the minimum input voltage in which the condition of RESETB pin being 0.1V or lower than 0.1V. (Herein, pull-up resistance is set as 100k Ω in the case of the Nch open-drain output type.)

Manual Reset (MR) Function

By setting MR pin as "L", the output of RESETB can be forced to set "L". After pull-down the MR pin to "L", the delay time (t_{MR}) to the output "L" from RESETB is $1\mu\text{s}$ as maximum. MR pin is pulled-up via the built-in resistor. (Typ. $110\text{k}\Omega$). If MR pin voltage $> V_{DD}$ voltage, a current flows into MR pin. However, the current value is limit by the pull-up resistor, therefore there is not bad impact on the operation. When the "L" signal is input to MR pin, the discharge of C_D pin capacitor (C_D) starts. If the term of "L" for MR pin is short, C_D will not be discharged enough. As a result, the delay time after setting "H" for MR pin will be shorter than expected. Because of this, confirm the operation under the same conditions as users' applications. For example, in case of C_D is set at $0.1\mu\text{F}$, and the condition to maintain the delay time value after MR pin's returning to "H", is described as the minimum "L" term of MR pin, or $150\mu\text{s}$. When MR input pulse (t_{MRW}) is less than $3.0\mu\text{s}$, output delay time (t_{PLH}) might not exist.

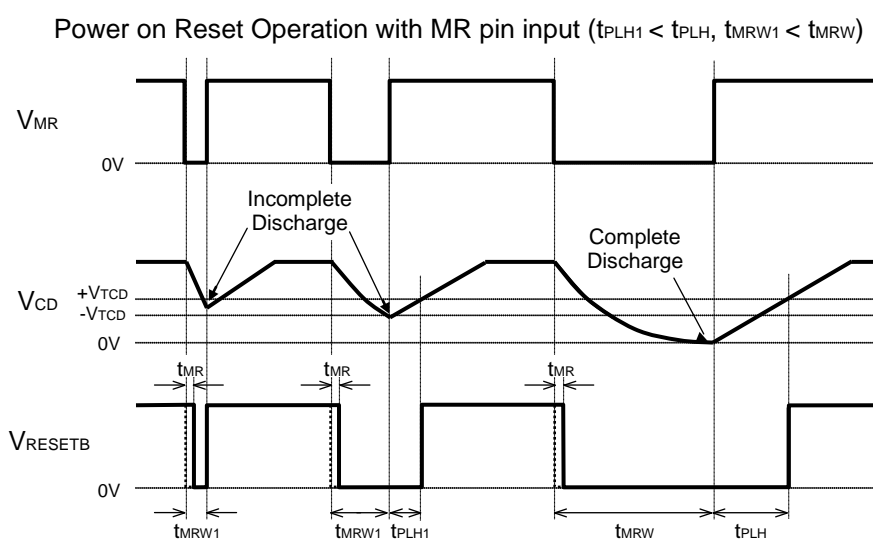

Inhibit (INH) Function

If INH pin is set at "L", the watchdog timer stops monitoring the clock, and the RESETB output will be dominant by the voltage detector's operation. Therefore, if the supply voltage is set at more than the detector threshold level, RESETB outputs "H" regardless the clock pulse. INH pin is pulled up with a resistor (Typ. $110\text{k}\Omega$) internally.

RESETB Output

RESETB pin's output type is selectable either the Nch open-drain output or CMOS output. If the Nch open-drain type output is selected, the RESETB pin is pulled up with an external resistor to an appropriate voltage source.

Clock Pulse Input

Built-in watchdog timer is cleared with the SCK clock pulse within the watchdog timeout period.

APPLICATION INFORMATION

Typical Application Circuits

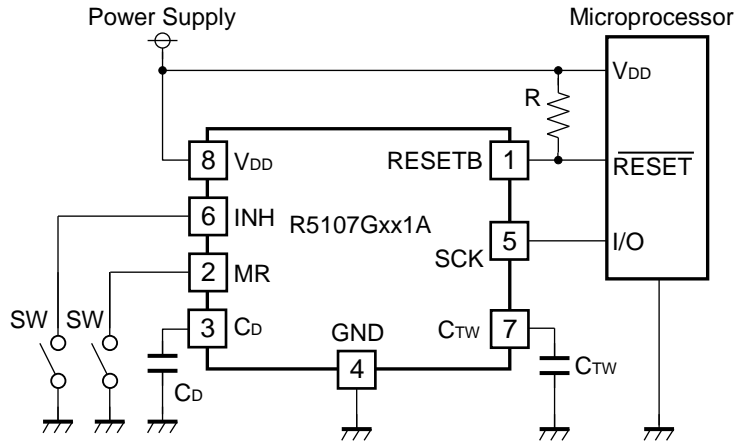

R5107Gxx1A

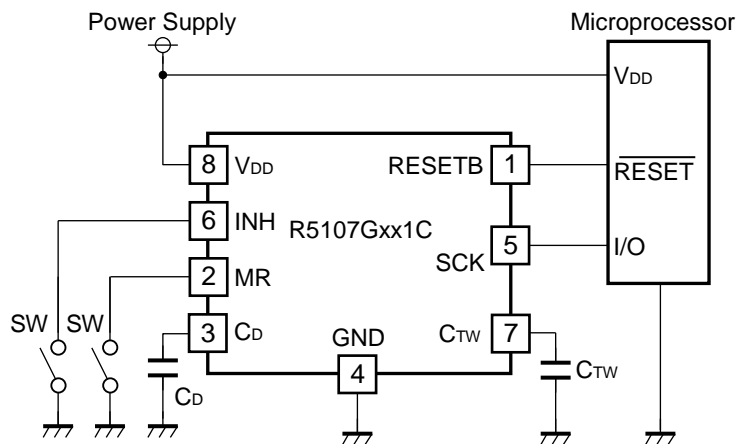

R5107Gxx1C

TECHNICAL NOTES

When connecting resistors to the device's input pin

When connecting a resistor (R1) to an input of this device, the input voltage decreases by [Device's Consumption Current] x [Resistance Value] only. And, the cross conduction current⁽¹⁾, which occurs when changing from the detecting state to the release state, is decreased the input voltage by [Cross Conduction Current] x [Resistance Value] only. And then, this device will enter the re-detecting state if the input voltage reduction is larger than the difference between the detector voltage and the released voltage.

When the input resistance value is large and the VDD is gone up at mildly in the vicinity of the released voltage, repeating the above operation may result in the occurrence of output.

As shown in Figure A/B, set R1 to become 100kΩ or less as a guide, and connect C_{IN}⁽²⁾ of 0.1μF and more to between the input pin and GND. Besides, make evaluations including temperature properties under the actual usage condition, with using the evaluation board like this way. As result, make sure that the cross conduction current has no problem.

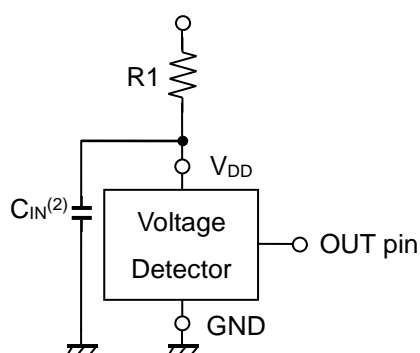

Figure A

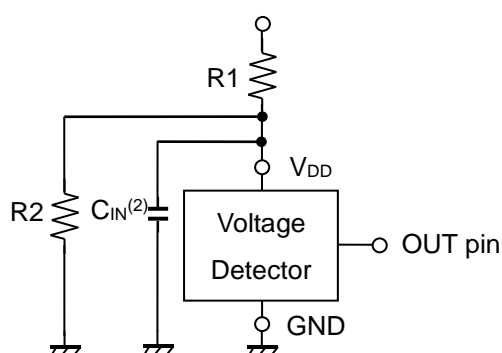

Figure B

⁽¹⁾ In the CMOS output type, a charging current for OUT pin is included.

⁽²⁾ Note the bias dependence of capacitors.

TYPICAL CHARACTERISTICS

Note: Typical Characteristics are intended to be used as reference data; they are not guaranteed.

1) Supply Current vs. Input Voltage

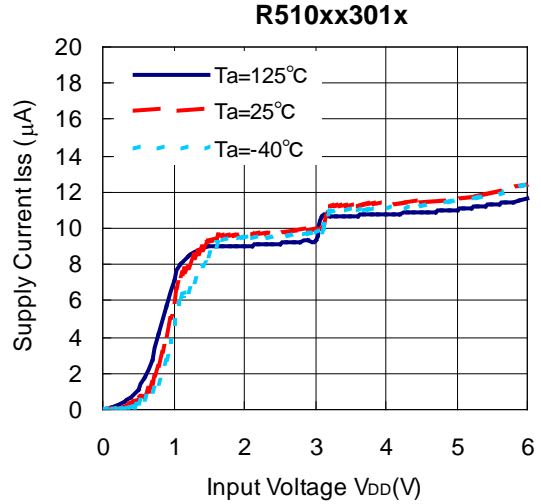
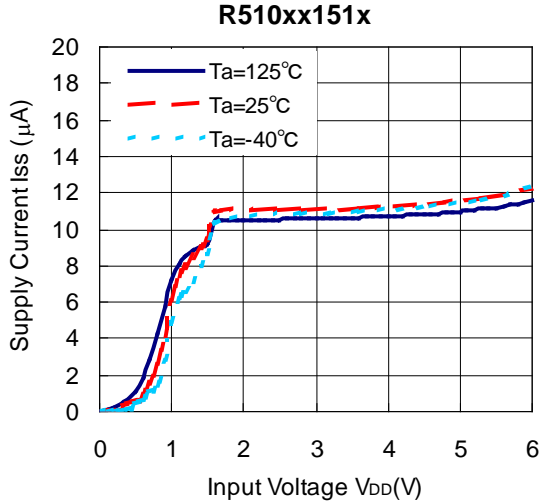

2) Detector Threshold vs. Temperature

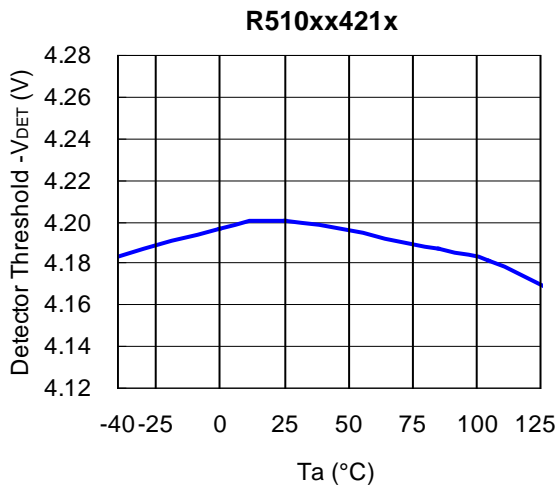
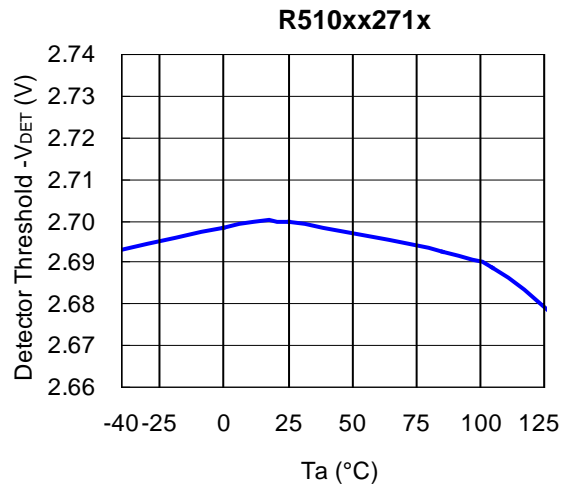
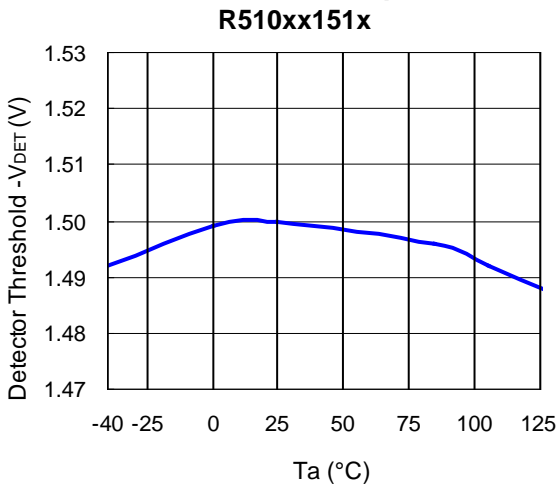

3) Detector Threshold Hysteresis vs. Temperature

R510xx151x

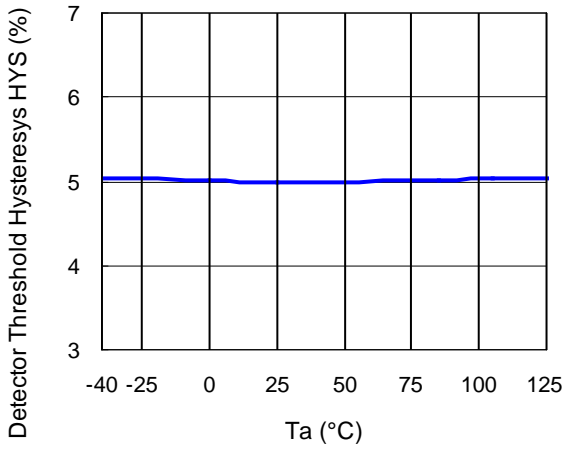

R510xx271x

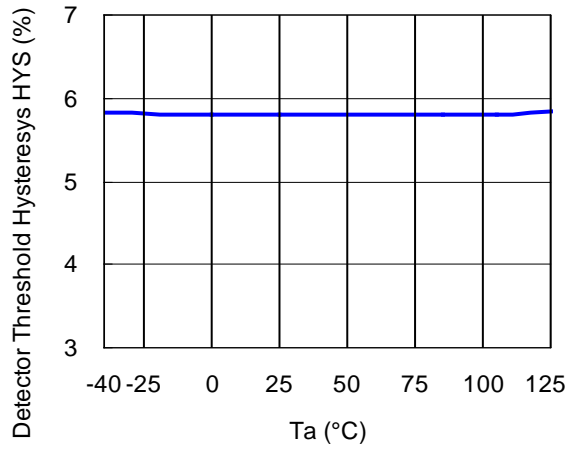

R510xx421x

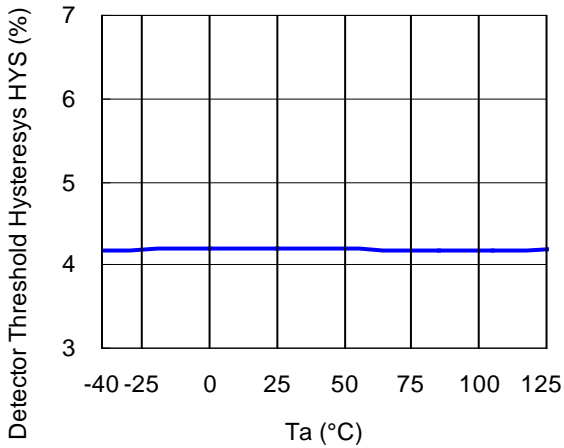

4) Nch Driver Output Current vs. V_{DS}

R510xx

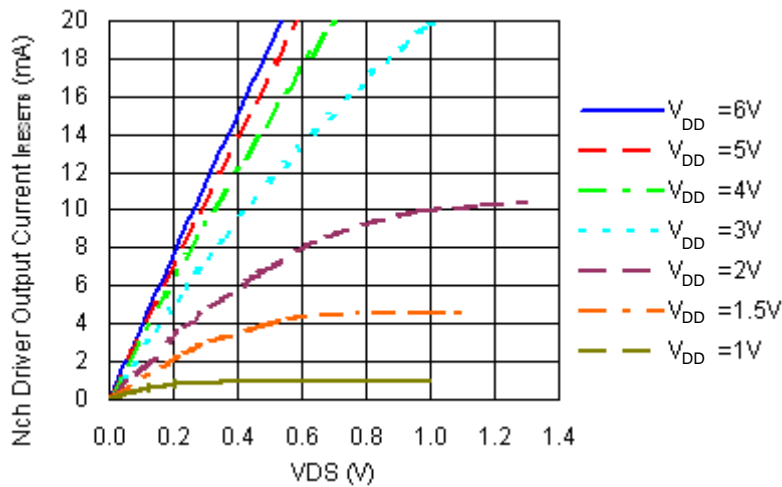

5) Nch Driver Output Current vs. Input Voltage

R510xx

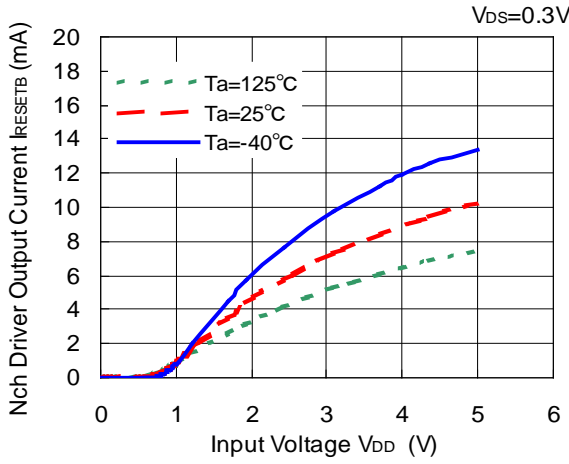

R510xx

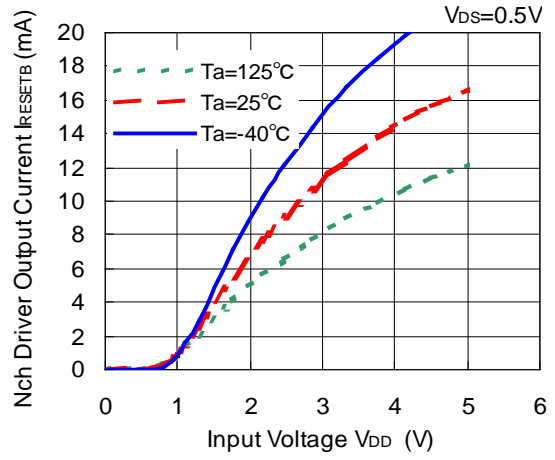

6) Pch Driver Output Current vs. Input Voltage

R510xx

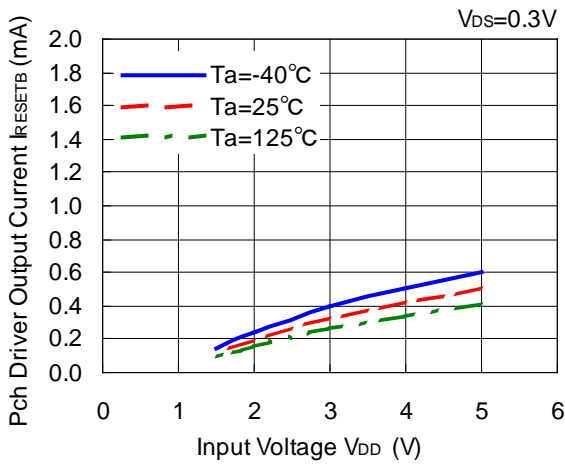

R510xx

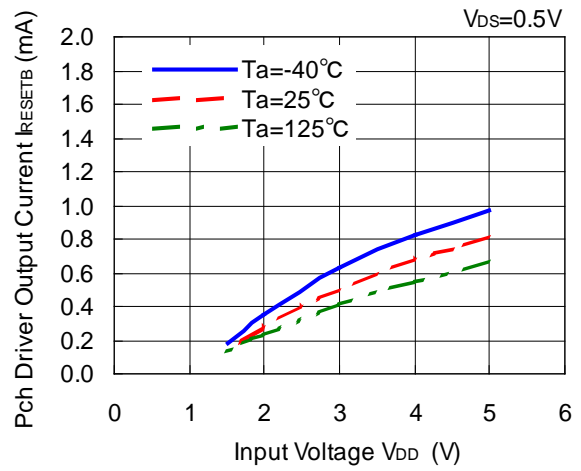

R510xx

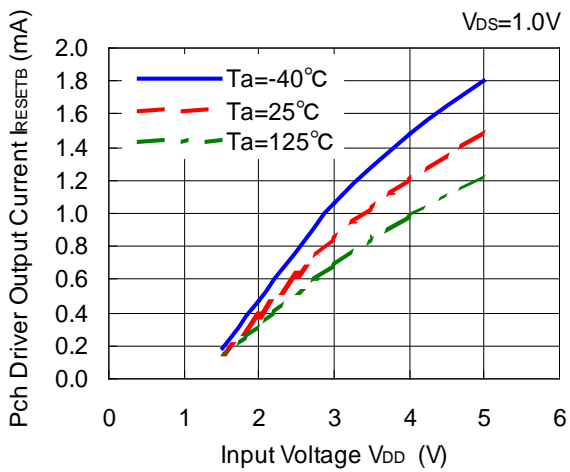

7) Released Delay Time vs. Input Voltage
R510xx

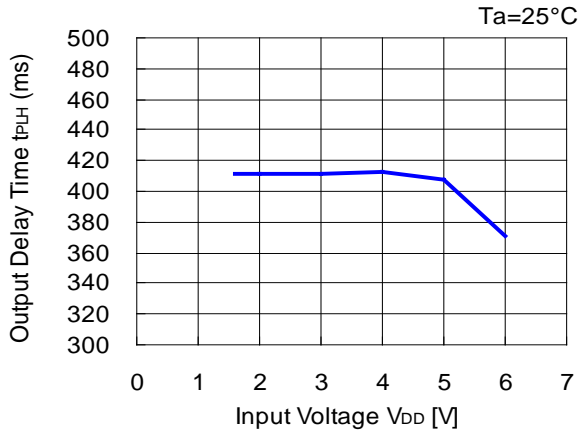

8) Released Delay Time vs. Temperature
R510xx

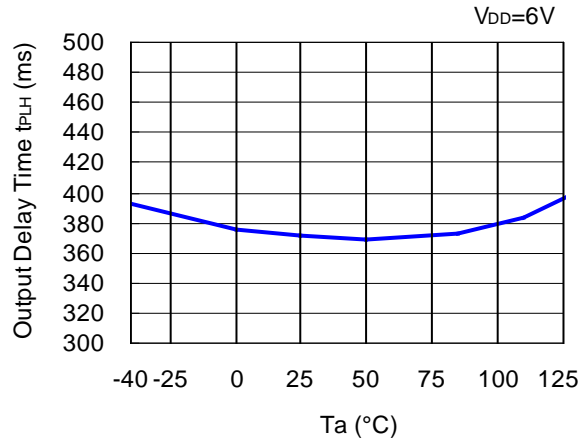

9) Detector Output Delay Time vs. Temperature
R510xx

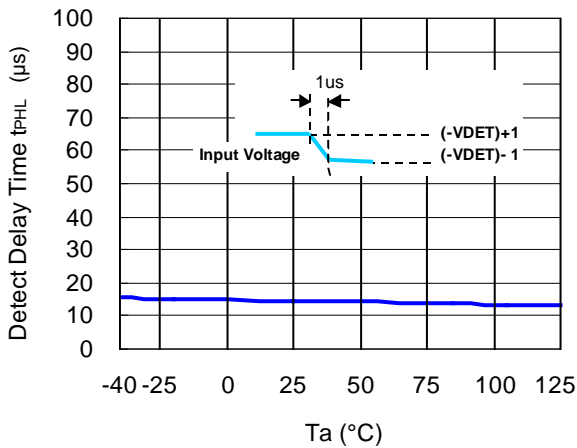

10) WDT Reset Timer vs. Temperature
R510xx

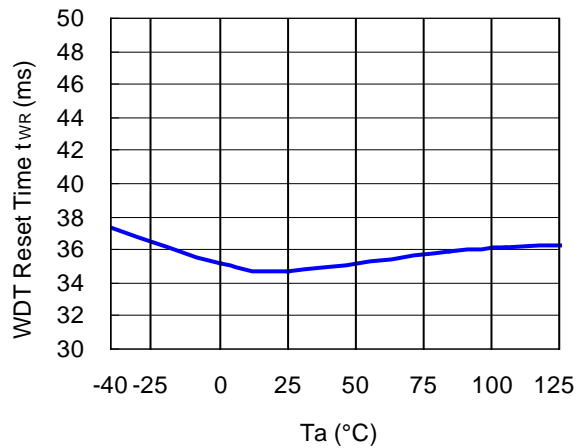

11) WDT Timeout Period vs. Temperature
R510xx

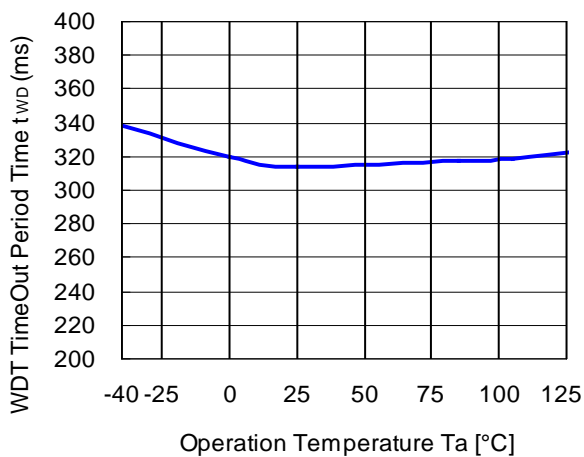

12) WDT Reset Timer vs. Input Voltage
R510xx

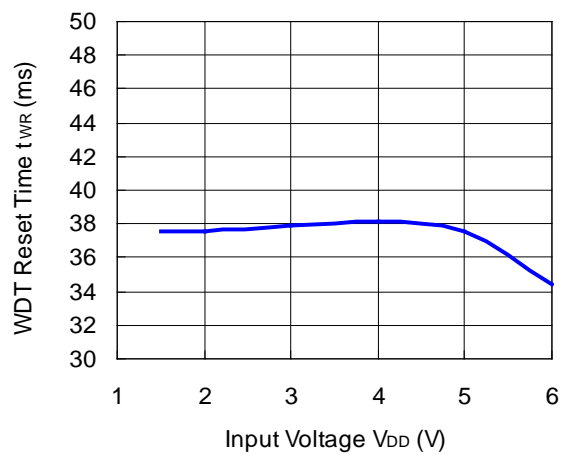

13) WDT Timeout Period vs. Input Voltage

R510xx

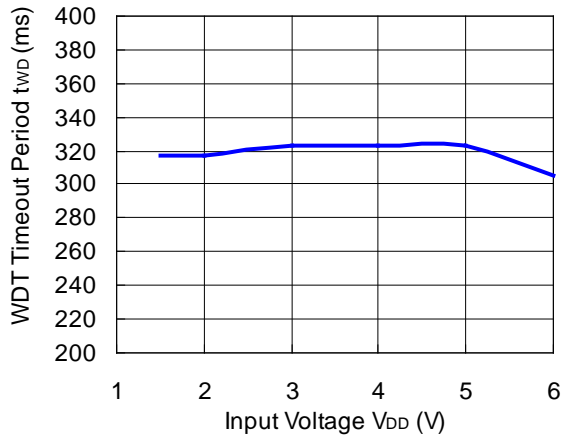

14) Output Delay Time vs. External Capacitance

R510xx

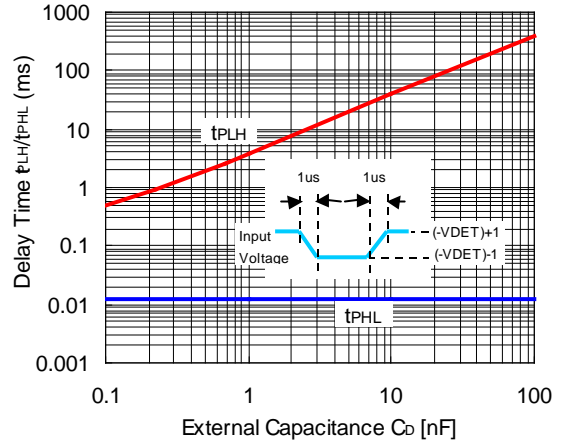

The power dissipation of the package is dependent on PCB material, layout, and environmental conditions. The following conditions are used in this measurement.

Measurement Conditions

	Standard Test Land Pattern
Environment	Mounting on Board (Wind Velocity = 0 m/s)
Board Material	Glass Cloth Epoxy Plastic (Double-Sided Board)
Board Dimensions	40 mm × 40 mm × 1.6 mm
Copper Ratio	Top Side: Approx. 50% Bottom Side: Approx. 50%
Through-holes	φ 0.5 mm × 44 pcs

Measurement Result

(Ta = 25°C, Tjmax = 150°C)

	Standard Test Land Pattern
Power Dissipation	475 mW
Thermal Resistance	$\theta_{ja} = (150 - 25^\circ\text{C}) / 0.475 \text{ W} = 263^\circ\text{C/W}$
	$\theta_{jc} = 60^\circ\text{C/W}$

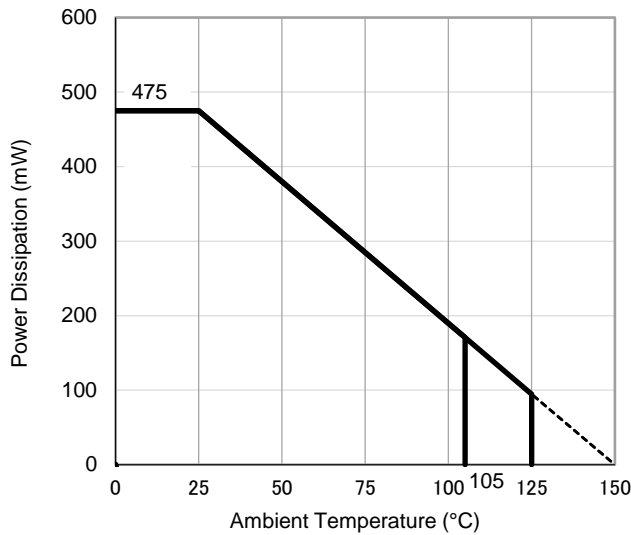

Power Dissipation vs. Ambient Temperature

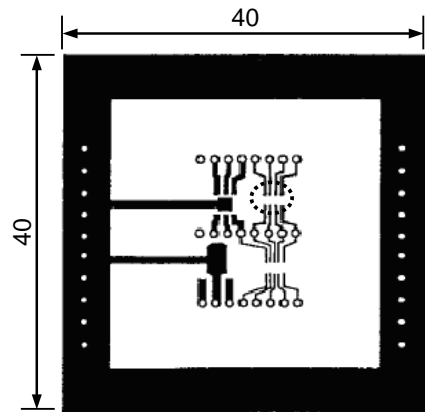

○ IC Mount Area (mm)

Measurement Board Pattern

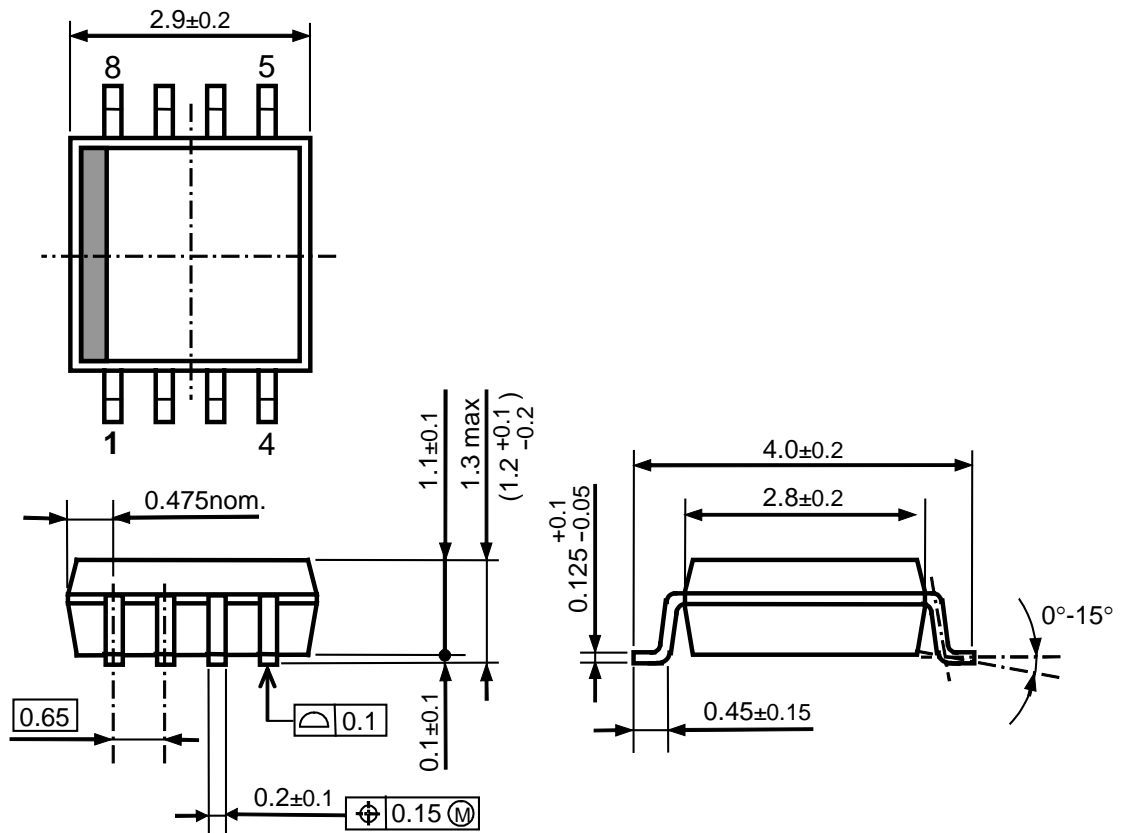

SSOP-8G Package Dimensions (Unit: mm)

①②③④: Product Code ... Refer to the following table

⑤⑥: Lot Number ... Alphanumeric Serial Number

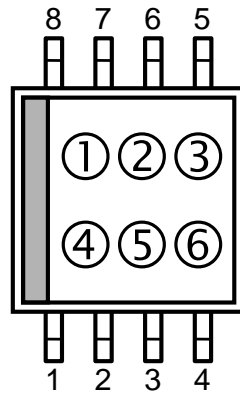

SSOP-8G Marking Specification

PART MARKINGS**R5107G**

MK-R5107G-JE-A

R5107Gxx1A

Product Name	①②③④
R5107G151A	E 0 1 A
R5107G161A	E 0 2 A
R5107G171A	E 0 3 A
R5107G181A	E 0 4 A
R5107G191A	E 0 5 A
R5107G201A	E 0 6 A
R5107G211A	E 0 7 A
R5107G221A	E 0 8 A
R5107G231A	E 0 9 A
R5107G241A	E 1 0 A
R5107G251A	E 1 1 A
R5107G261A	E 1 2 A
R5107G271A	E 1 3 A
R5107G281A	E 1 4 A
R5107G291A	E 1 5 A
R5107G301A	E 1 6 A
R5107G311A	E 1 7 A
R5107G321A	E 1 8 A
R5107G331A	E 1 9 A
R5107G341A	E 2 0 A
R5107G351A	E 2 1 A
R5107G361A	E 2 2 A
R5107G371A	E 2 3 A
R5107G381A	E 2 4 A
R5107G391A	E 2 5 A
R5107G401A	E 2 6 A
R5107G411A	E 2 7 A
R5107G421A	E 2 8 A
R5107G431A	E 2 9 A
R5107G441A	E 3 0 A
R5107G451A	E 3 1 A
R5107G461A	E 3 2 A
R5107G471A	E 3 3 A
R5107G481A	E 3 4 A
R5107G491A	E 3 5 A
R5107G501A	E 3 6 A
R5107G511A	E 3 7 A
R5107G521A	E 3 8 A
R5107G531A	E 3 9 A
R5107G541A	E 4 0 A
R5107G551A	E 4 1 A

R5107Gxx1C

Product Name	①②③④
R5107G151C	F 0 1 A
R5107G161C	F 0 2 A
R5107G171C	F 0 3 A
R5107G181C	F 0 4 A
R5107G191C	F 0 5 A
R5107G201C	F 0 6 A
R5107G211C	F 0 7 A
R5107G221C	F 0 8 A
R5107G231C	F 0 9 A
R5107G241C	F 1 0 A
R5107G251C	F 1 1 A
R5107G261C	F 1 2 A
R5107G271C	F 1 3 A
R5107G281C	F 1 4 A
R5107G291C	F 1 5 A
R5107G301C	F 1 6 A
R5107G311C	F 1 7 A
R5107G321C	F 1 8 A
R5107G331C	F 1 9 A
R5107G341C	F 2 0 A
R5107G351C	F 2 1 A
R5107G361C	F 2 2 A
R5107G371C	F 2 3 A
R5107G381C	F 2 4 A
R5107G391C	F 2 5 A
R5107G401C	F 2 6 A
R5107G411C	F 2 7 A
R5107G421C	F 2 8 A
R5107G431C	F 2 9 A
R5107G441C	F 3 0 A
R5107G451C	F 3 1 A
R5107G461C	F 3 2 A
R5107G471C	F 3 3 A
R5107G481C	F 3 4 A
R5107G491C	F 3 5 A
R5107G501C	F 3 6 A
R5107G511C	F 3 7 A
R5107G521C	F 3 8 A
R5107G531C	F 3 9 A
R5107G541C	F 4 0 A
R5107G551C	F 4 1 A

1. The products and the product specifications described in this document are subject to change or discontinuation of production without notice for reasons such as improvement. Therefore, before deciding to use the products, please refer to our sales representatives for the latest information thereon.
2. The materials in this document may not be copied or otherwise reproduced in whole or in part without the prior written consent of us.
3. This product and any technical information relating thereto are subject to complementary export controls (so-called KNOW controls) under the Foreign Exchange and Foreign Trade Law, and related politics ministerial ordinance of the law. (Note that the complementary export controls are inapplicable to any application-specific products, except rockets and pilotless aircraft, that are insusceptible to design or program changes.) Accordingly, when exporting or carrying abroad this product, follow the Foreign Exchange and Foreign Trade Control Law and its related regulations with respect to the complementary export controls.
4. The technical information described in this document shows typical characteristics and example application circuits for the products. The release of such information is not to be construed as a warranty of or a grant of license under our or any third party's intellectual property rights or any other rights.
5. The products listed in this document are intended and designed for automotive applications. Those customers intending to use a product in an application requiring extreme quality and reliability, for example, in a highly specific application where the failure or misoperation of the product could result in human injury or death should first contact us.
 - Aerospace Equipment
 - Equipment Used in the Deep Sea
 - Power Generator Control Equipment (nuclear, steam, hydraulic, etc.)
 - Life Maintenance Medical Equipment
 - Fire Alarms / Intruder Detectors
 - Vehicle Control Equipment (airplane, railroad, ship, etc.)
 - Various Safety Devices
 - Traffic control system
 - Combustion equipment

In case your company desires to use this product for any applications other than general electronic equipment mentioned above, make sure to contact our company in advance. Note that the important requirements mentioned in this section are not applicable to cases where operation requirements such as application conditions are confirmed by our company in writing after consultation with your company.

6. We are making our continuous effort to improve the quality and reliability of our products, but semiconductor products are likely to fail with certain probability. In order to prevent any injury to persons or damages to property resulting from such failure, customers should be careful enough to incorporate safety measures in their design, such as redundancy feature, fire containment feature and fail-safe feature. We do not assume any liability or responsibility for any loss or damage arising from misuse or inappropriate use of the products.
7. The products have been designed and tested to function within controlled environmental conditions. Do not use products under conditions that deviate from methods or applications specified in this datasheet. Failure to employ the products in the proper applications can lead to deterioration, destruction or failure of the products. We shall not be responsible for any bodily injury, fires or accident, property damage or any consequential damages resulting from misuse or misapplication of the products.
8. Quality Warranty
 - 8-1. Quality Warranty Period

In the case of a product purchased through an authorized distributor or directly from us, the warranty period for this product shall be one (1) year after delivery to your company. For defective products that occurred during this period, we will take the quality warranty measures described in section 8-2. However, if there is an agreement on the warranty period in the basic transaction agreement, quality assurance agreement, delivery specifications, etc., it shall be followed.
 - 8-2. Quality Warranty Remedies

When it has been proved defective due to manufacturing factors as a result of defect analysis by us, we will either deliver a substitute for the defective product or refund the purchase price of the defective product.
Note that such delivery or refund is sole and exclusive remedies to your company for the defective product.
 - 8-3. Remedies after Quality Warranty Period

With respect to any defect of this product found after the quality warranty period, the defect will be analyzed by us. On the basis of the defect analysis results, the scope and amounts of damage shall be determined by mutual agreement of both parties. Then we will deal with upper limit in Section 8-2. This provision is not intended to limit any legal rights of your company.
9. Anti-radiation design is not implemented in the products described in this document.
10. The X-ray exposure can influence functions and characteristics of the products. Confirm the product functions and characteristics in the evaluation stage.
11. WLCSP products should be used in light shielded environments. The light exposure can influence functions and characteristics of the products under operation or storage.
12. Warning for handling Gallium and Arsenic (GaAs) products (Applying to GaAs MMIC, Photo Reflector). These products use Gallium (Ga) and Arsenic (As) which are specified as poisonous chemicals by law. For the prevention of a hazard, do not burn, destroy, or process chemically to make them as gas or power. When the product is disposed of, please follow the related regulation and do not mix this with general industrial waste or household waste.
13. Please contact our sales representatives should you have any questions or comments concerning the products or the technical information.



Nisshinbo Micro Devices Inc.

Official website

<https://www.nisshinbo-microdevices.co.jp/en/>

Purchase information

<https://www.nisshinbo-microdevices.co.jp/en/buy/>