



MUSES72320



±18V Operation 2-Channel Electronic Volume

FEATURES

- Operating Voltage ± 8.5 to ± 18 V
- 3-Wired Serial Control
Chip Address Select Function
- Selectable 8-Chip Address
Available for using eight chips on same serial bus line
- Low Output Noise
*It conforms to the characteristic of an external operational amplifier.
- Low Distortion
*It conforms to the characteristic of an external operational amplifier.
- Volume
0dB to -111.5 dB / 0.25 dBstep, MUTE
 $+31.5$ to 0dB / 0.5 dBstep
- Channel Separation -120 dB typ.
- Zero Cross Detection circuit Detection
- CMOS Technology
- Package Outline SSOP32

GENERAL DESCRIPTION

The MUSES72320 is a ± 18 V operation 2-channel electronic volume, which is optimized for high-end audio and professional audio applications with advanced circuitry and layout. The MUSES72320 performs low noise and low distortion characteristics and with resistance ladder circuit.

All of functions are controlled via three-wired serial bus. Selectable 8-Chip address is available for using eight chips on same serial bus line.

It's suitable for highly linear volume control of Hi-fi audio systems.

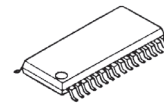

MUSES72320V

BLOCK DIAGRAM



The MUSES logo is a trademark or registered trademark of Nisshinbo Micro Devices Inc.

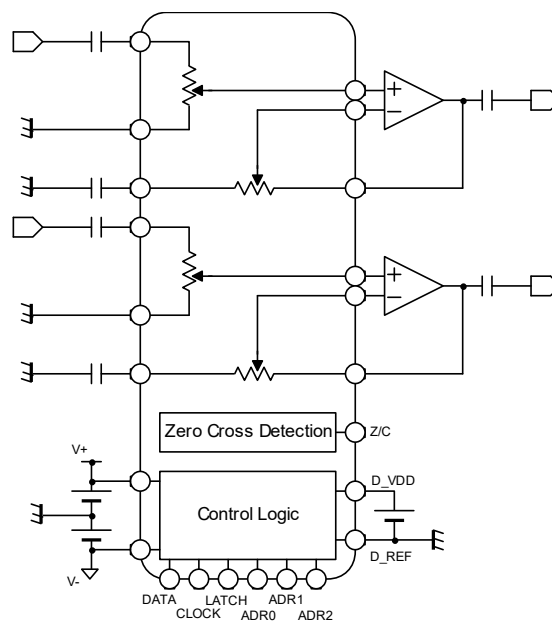

■ PIN FUNCTION

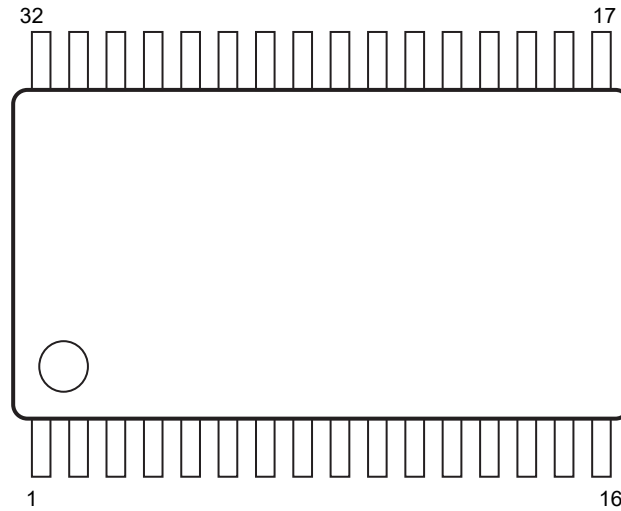

No.	SYMBOL	FUNCTION	No.	SYMBOL	FUNCTION
1	Z/C REFL	Lch Zero Cross Detection circuit Reference Voltage	17	D_VDD	Digital block Power Supply
2	L_REF	Lch Reference Voltage	18	DATA	Control data signal input
3	L+	Lch Opamp non-inverting input connect terminal	19	CLOCK	Clock signal input
4	L_REF	Lch Reference Voltage	20	LATCH	Latch signal input
5	L-	Lch Opamp inverting input connect terminal	21	D_REF	Digital block Reference Voltage
6	L_REF	Lch Reference Voltage	22	V+	Power Supply (+)
7	OutL	Lch output	23	InR	Rch input
8	DCCAP_L	Switching noise rejection capacitor (Lch)	24	V+	Power Supply (+)
9	DCCAP_R	Switching noise rejection capacitor (Rch)	25	V -	Power Supply (-)
10	OutR	Rch output	26	InL	Lch input
11	R_REF	Rch Reference Voltage	27	V -	Power Supply (-)
12	R-	Rch Opamp inverting input connect terminal	28	D_CAP	Digital block Noise Rejection Capacitor terminal
13	R_REF	Rch Reference Voltage	29	ADR2	Chip address setting terminal 2
14	R+	Rch Opamp non-inverting input connect terminal	30	ADR1	Chip address setting terminal 1
15	R_REF	Rch Reference Voltage	31	ADR0	Chip address setting terminal 0
16	Z/C REFR	Rch Zero Cross Detection circuit Reference Voltage	32	Z/C	Zero Cross Detection circuit ON/OFF setting terminal

■ ABSOLUTE MAXIMUM RATING (Ta=25°C)

PARAMETER	SYMBOL	RATING	UNIT
Power Supply Voltage	V+/V-	+20/-20	V
Maximum Input Voltage	V _{IM}	V+/V-	V
Power Dissipation	P _D	1000 NOTE: EIA/JEDEC STANDARD Test board (76.2x114.3x1.6mm, 2layer, FR-4) mounting	mW
Operating Temperature Range	Topr	-40 ~ +85	°C
Storage Temperature Range	Tstg	-40 ~ +125	°C

■ ELECTRICAL CHARACTERISTICS

PARAMETER	SYMBOL	TEST CONDITION	MIN.	TYP.	MAX.	UNIT
Power Supply (Ta=25°C, V+/V-=±15V, unless otherwise specified)						
Operating Voltage	V+/V-		±8.5	±15.0	±18.0	V
Supply Current 1	I _{CC}	No signal	-	2.0	10.0	mA
Supply Current 2	I _{EE}	No signal	-	2.0	10.0	mA

Input/Output Characteristics 1

(Ta=25°C, V+/V-=±15V, V_{IN}=2Vrms, f=1kHz, Volume=0dB, Gain=0dB, V_{OUT} with MUSES01, R_L=47kΩ, unless otherwise specified)

Maximum Input Voltage	V _{IM}	f=1kHz, THD=1% Volume=-20dB	10.9	-	-	Vrms
Voltage Gain 1	G _{V1}	V _{IN} =2Vrms, f=1kHz	-0.5	0	+0.5	dB
Voltage Gain 2	G _{V2}	V _{IN} =200mVrms, f=1kHz Gain=+15dB	+14	+15	+16	dB
Voltage Gain Error 1	ΔG _{V1}	V _{IN} =2Vrms, f=1kHz	-0.5	0	+0.5	dB
Voltage Gain Error 2	ΔG _{V2}	V _{IN} =2Vrms, f=1kHz Volume=-60dB	-1.0	0	+1.0	dB
Maximum Attenuation	A _{TT}	V _{IN} =4Vrms, f=1kHz Volume=-111.5dB, A-weight	-	-111.5	-	dB
Mute level	Mute	f=1kHz, V _{IN} =4Vrms Volume=Mute, A-weight	-	-120	-	dB
Channel Separation 1	CS1	f=1kHz, V _{IN} =2Vrms, Rg=0Ω A-weight	-	-110	-90	dB
Channel Separation 2	CS2	f=20kHz, V _{IN} =2Vrms, Rg=0Ω	-	-90	-	dB
Input Impedance	R _{IN}	23pin, 26pin	14	20	-	kΩ

Input/Output Characteristics 2

(Ta=25°C, V+/V-=±15V, V_{IN}=2Vrms, f=1kHz, Volume=0dB, Gain=0dB, V_{OUT} with MUSES01, R_L=47kΩ, unless otherwise specified)

Maximum Output Voltage	V _{OM}	f=1kHz, THD=1% Volume=-6dB, Gain=+6dB	-	9.5	-	Vrms
Total Harmonic Distortion 1	THD1	f=1kHz, V _{IN} =1Vrms BW=400Hz-30kHz	-	0.0005	-	%
Total Harmonic Distortion 2	THD2	f=10kHz, V _{IN} =1Vrms BW=400Hz-30kHz	-	0.001	-	%

■ ELECTRICAL CHARACTERISTICS

PARAMETER	SYMBOL	TEST CONDITION	MIN.	TYP.	MAX.	UNIT
Input/Output Characteristics 3						
(Ta=25°C, V ⁺ /V ⁻ =±15V, V _{IN} =2V _{rms} , f=1kHz, Volume=0dB, V _{OUT} : 3pin, 14pin, R _L =100kΩ, unless otherwise specified)						
Output Noise1	V _{NO1}	R _g =0Ω, A-weight	-	-118 (1.26μ)	-100 (10μ)	dBV (V _{rms})
Output Noise2	V _{NO2}	Volume=-111.5dB R _g =0Ω, A-weight	-	-118 (1.26μ)	-	dBV (V _{rms})

■ Logic Control Characteristics

PARAMETER	SYMBOL	TEST CONDITION	MIN.	TYP.	MAX.	UNIT
Digital block Power Supply Characteristics						
D_VDD Terminal Input Voltage	V _{DVDD}	17pin Terminal Input	-	-	0.8*V ⁺	V
D_REF Terminal Input Voltage	V _{DREF}	21pin Terminal Input	V ⁻	-	-	V
Digital block Supply Voltage Range	V _{DD}	V _{DD} = V _{DVDD} - V _{DREF}	3.0	5.0	6.0	V
Logic Control Terminal Characteristics						
(Ta=25°C, V ⁺ /V ⁻ =±15V, V _{DREF} =0V, unless otherwise specified)						
High Level Input Voltage1	V _{IH1}	DATA, CLOCK, LATCH	0.7*V _{DD}	-	V _{DD}	V
Low Level Input Voltage1	V _{IL1}	DATA, CLOCK, LATCH	0	-	0.3*V _{DD}	V
Chip Address / Zero cross Terminal Characteristics						
(Ta=25°C, V ⁺ /V ⁻ =±15V, V _{DREF} =0V, unless otherwise specified)						
High Level Input Voltage2	V _{IH2}	ADR0, ADR1, ADR2, Z/C	0.7*V _{DD}	-	V ⁺	V
Low Level Input Voltage2	V _{IL2}	ADR0, ADR1, ADR2, Z/C	0	-	0.3*V _{DD}	V

■ TERMINAL DESCRIPTION

PIN NO.	SYMBOL	FUNCTION	EQUIVALENT CIRCUIT	TERMINAL DC VOLTAGE
23 26	InR InL	Rch input Lch input		0V
2 4 6 11 13 15	L_REF R_REF	Lch Reference Voltage Rch Reference Voltage		0V
3 14	L+ R+	Lch Opamp non-inverting input connect terminal Rch Opamp non-inverting input connect terminal		0V
5 12	L- R-	Lch Opamp inverting input connect terminal Rch Opamp inverting input connect terminal		0V

■ TERMINAL DESCRIPTION

PIN NO.	SYMBOL	FUNCTION	EQUIVALENT CIRCUIT	TERMINAL DC VOLTAGE
7 10	OutL OutR	Lch output Rch output		0V
8 9	DCCAP_L DCCAP_R	Switching noise rejection capacitor (Lch) Switching noise rejection capacitor (Rch)		0V
16 1	Z/C REFR Z/C REFL	Rch Zero Cross Detection circuit Reference Voltage Lch Zero Cross Detection circuit Reference Voltage		0V
18 19 20	DATA CLOCK LATCH	Control data signal input Clock signal input Latch signal input		-

■ **TERMINAL DESCRIPTION**

PIN NO.	SYMBOL	FUNCTION	EQUIVALENT CIRCUIT	TERMINAL DC VOLTAGE
21	D_REF	Digital block Reference Voltage		-
17	D_VDD	Digital block Power Supply		-
22 24	V+	Power Supply (+)		V+
32 29 30 31	Z/C ADR2 ADR1 ADR0	Zero Cross Detection circuit ON/OFF setting terminal Chip address setting terminal 2 Chip address setting terminal 1 Chip address setting terminal 0		-
28	D_CAP	Digital block Noise Rejection Capacitor terminal		0V

■ TEST CIRCUIT 1

Supply Current 1 (I_{CC}), Supply Current 1 (I_{EE})

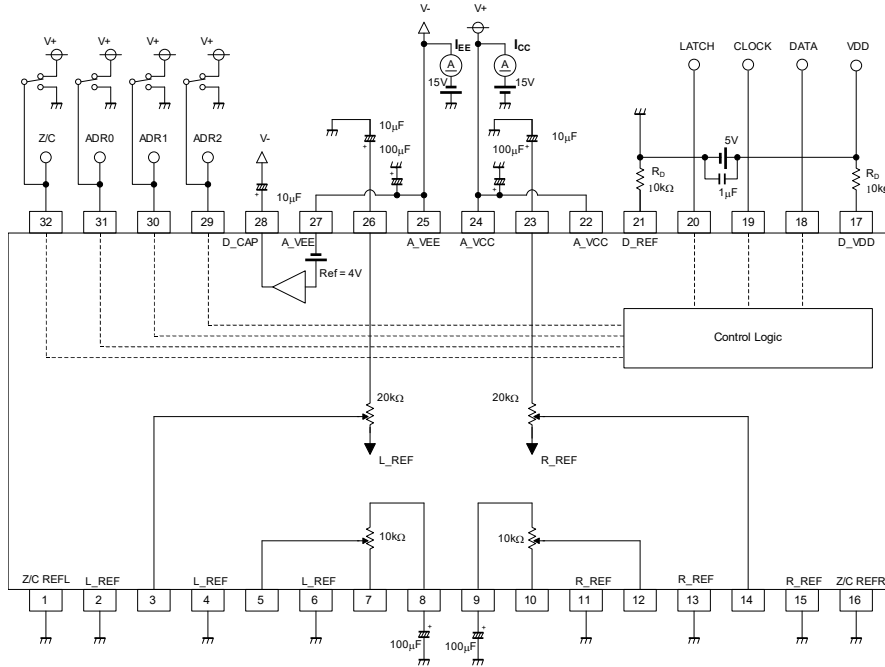

■ TEST CIRCUIT 2

Maximum Input Voltage (V_{IM}), Maximum Output Voltage (V_{OM}), Voltage Gain 1 (G_{V1}), Voltage Gain 2 (G_{V2}), Maximum Attenuation (A_{TT}), Mute level Mute), Total Harmonic Distortion 1(THD1), Total Harmonic Distortion 2(THD2)

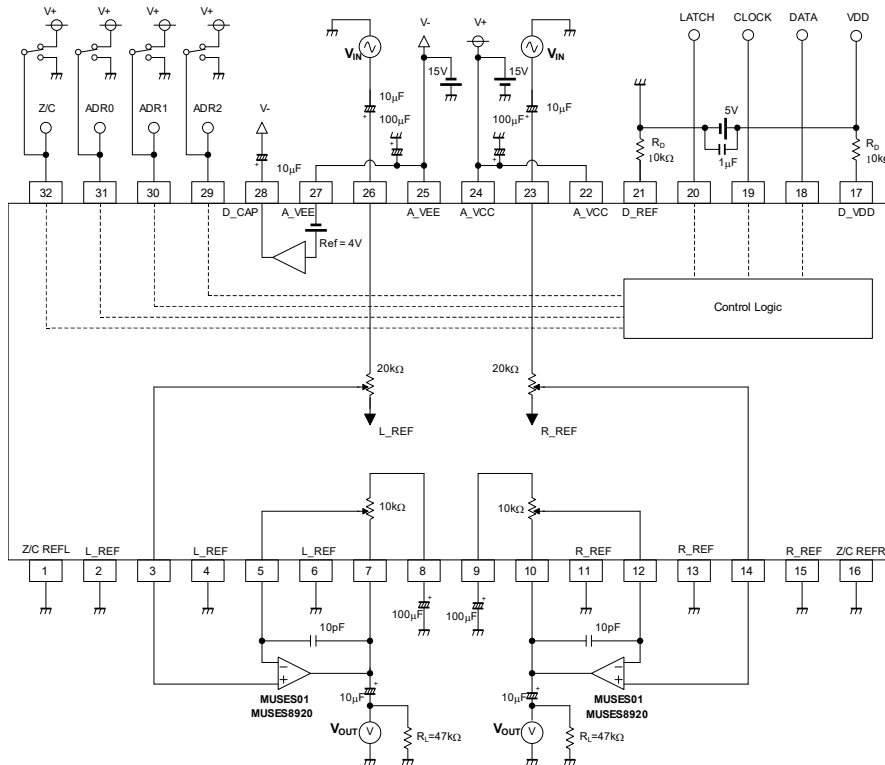

■ TEST CIRCUIT 3

Output Noise 1 (V_{NO1}), Output Noise 2 (V_{NO2})

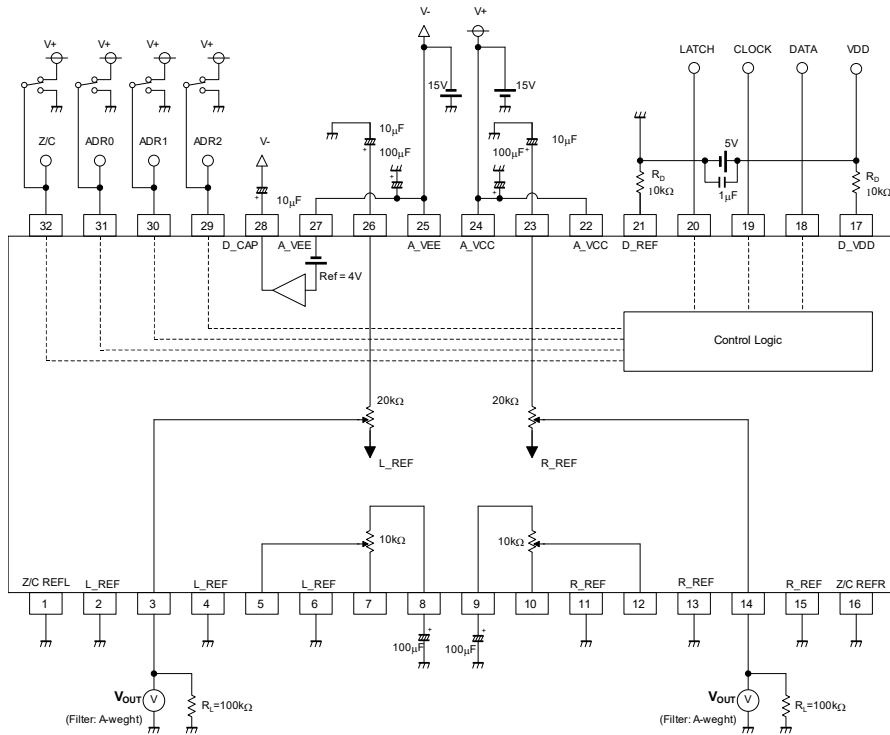

■ TEST CIRCUIT 4

Channel Separation 1 (CS1), Channel Separation 2 (CS2)

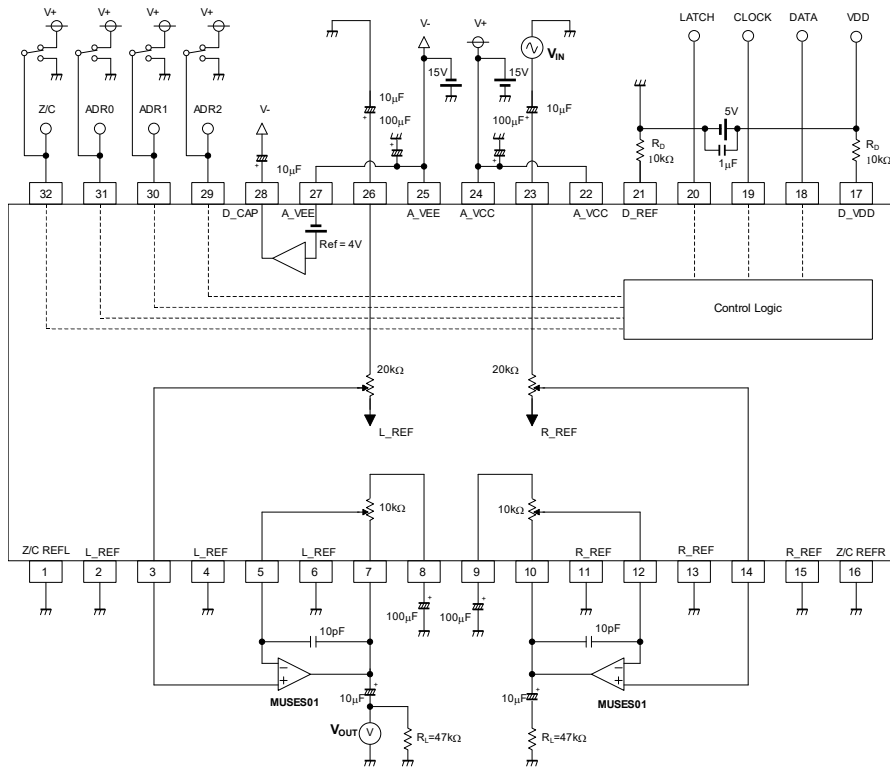

■ APPLICATION CIRCUIT

<Application circuit with J-FET Input type OpAmp.>

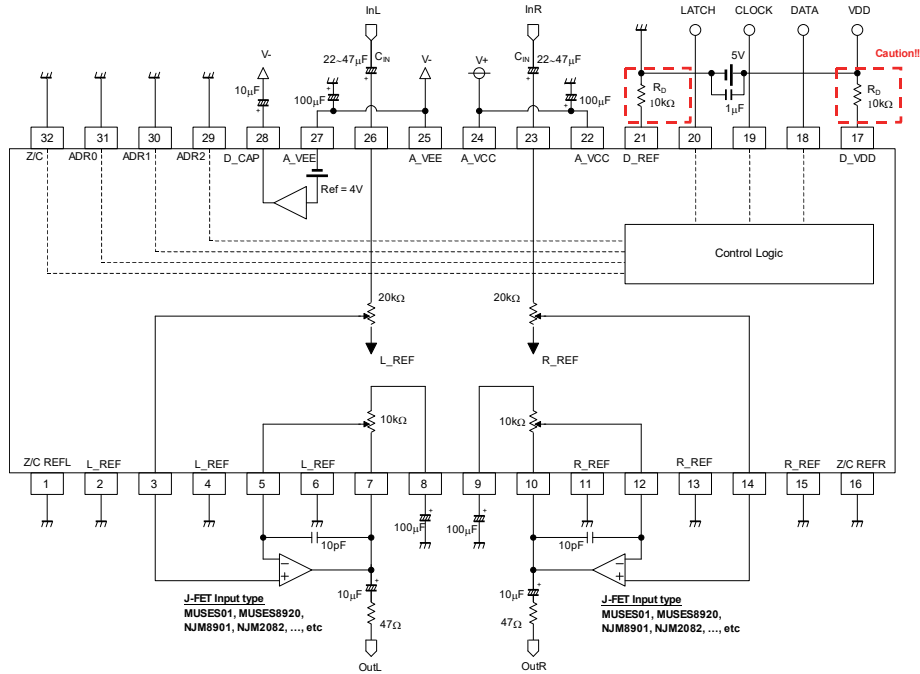

<Application circuit with Bipolar Input type OpAmp.>

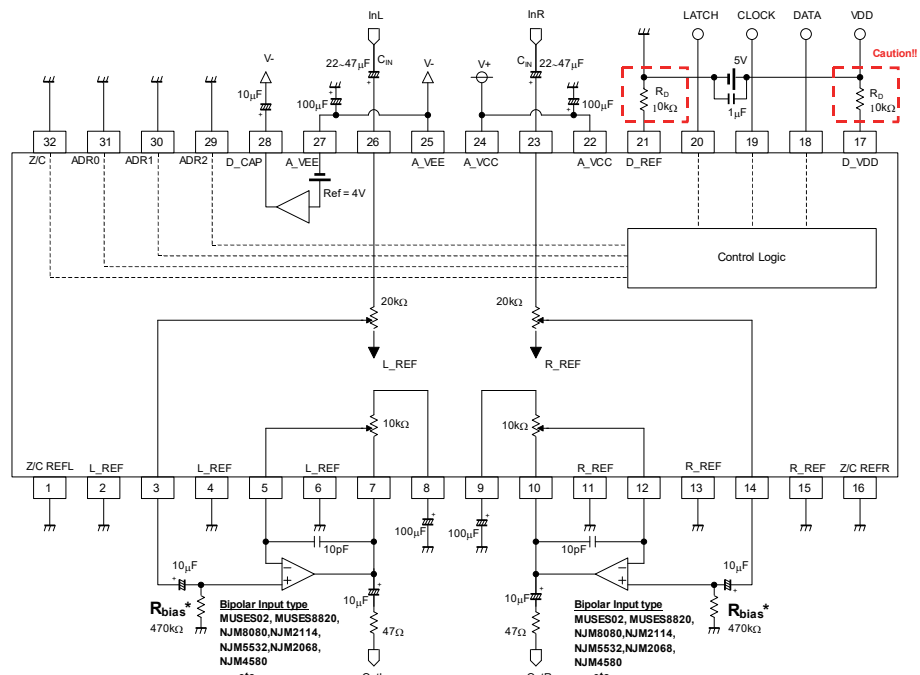

■ NOTES

It is necessary to add R_D to $10k\Omega$ for the over-current protection. Without this resistor, the IC may be damaged, depending on the power procedure.

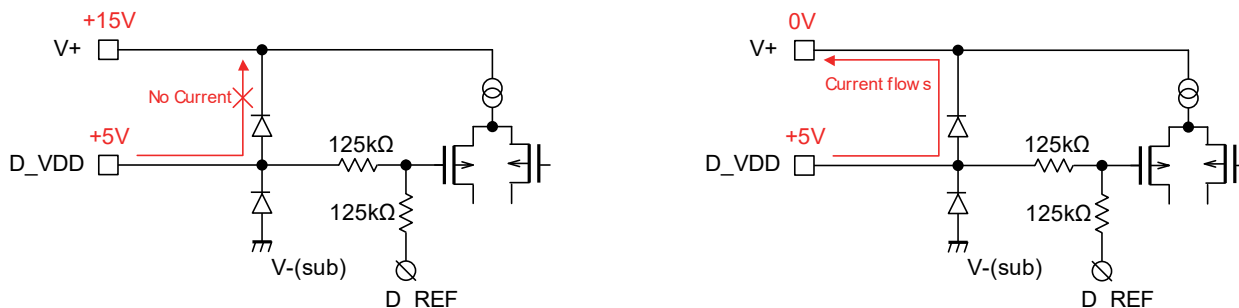

a) The power[V+] is greater than the power[D_VDD].

b) The power[V+] is less than the power[D_VDD].

Fig.1 Damaged path of the MUSES72320

The input coupling capacitors(C_{IN}) and the input resistance($R_{IN}=20k\Omega$) form a high-pass filter with the corner frequency determined in $[fc=1/(2\pi R_{IN}C_{IN})]$.

The R_{bias} affects the Volume(Att.) linearity characteristic. When R_{bias} value is too small, the amount of attenuation increases, so that the output amplitude becomes small and THD deteriorates by an internal analog switch. On the other hand, when R_{bias} is too large, it may be affected at the noise from the outside. Please decide resistance value after it verifies it enough by an actual application.

Separate for REF terminals for High and Middle voltage(AC) and REF terminals for Low voltage(AC) in the pattern design.

Pin No.	Function	Purpose
2	Lch Reference Voltage	for Low voltage(AC) signal
4	Lch Reference Voltage	for Middle voltage(AC) signal
6	Lch Reference Voltage	for High voltage(AC) signal
11	Rch Reference Voltage	for High voltage(AC) signal
13	Rch Reference Voltage	for Middle voltage(AC) signal
15	Rch Reference Voltage	for Low voltage(AC) signal

Table.1 Purpose of Reference Voltage Terminal

■ CONTROL DATA FORMAT

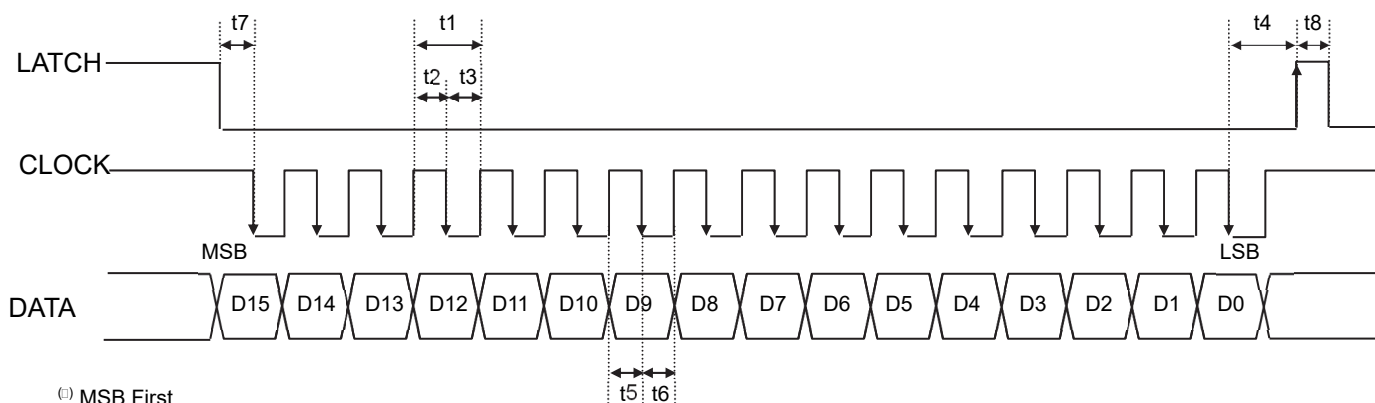

(e) MSB First

Note.) Set CLOCK in High to prevent incorrect operation during a standby period.

SYMBOL	PARAMETER	MIN	TYP	MAX	UNIT
t1	CLOCK Clock Width	4	-	-	μsec
t2	CLOCK Pulse Width (High)	2	-	-	μsec
t3	CLOCK Pulse Width (Low)	2	-	-	μsec
t4	LATCH Rise Hold Time	4	-	-	μsec
t5	DATA Setup Time	1.6	-	-	μsec
t6	DATA Hold Time	1.6	-	-	μsec
t7	CLOCK Setup Time	1.6	-	-	μsec
t8	LATCH High Pulse Width	1.6	-	-	μsec

■ CONTROL DATA

MUSES72320 control data is constructed with 16bits.

MSB															LSB
D15	D14	D13	D12	D11	D10	D9	D8	D7	D6	D5	D4	D3	D2	D1	D0
Data								Select Address				Chip Address			

MSB															LSB
D15	D14	D13	D12	D11	D10	D9	D8	D7	D6	D5	D4	D3	D2	D1	D0
Lch Volume Control (Att.)								0	0	0	0	0	*	*	*
0	Lch Volume Control (Gain)							0	0	0	1	0	*	*	*
Rch Volume Control (Att.)								0	0	1	0	0	*	*	*
0	Rch Volume Control (Gain)							0	0	1	1	0	*	*	*
L/R Cont 1	L/R Cont 2	Z/C	Don't Care	Don't Care	Don't Care	Don't Care	Don't Care	0	1	0	0	0	*	*	*

* Chip address is set by chip address select terminals (ADR0, ADR1, ADR2) status.

Chip address select terminal			Chip address			
ADR2 (29pin)	ADR1 (30pin)	ADR0 (31pin)	D3	D2	D1	D0
Low	Low	Low	0	0	0	0
Low	Low	High	0	0	0	1
Low	High	Low	0	0	1	0
Low	High	High	0	0	1	1
High	Low	Low	0	1	0	0
High	Low	High	0	1	0	1
High	High	Low	0	1	1	0
High	High	High	0	1	1	1

■ INITIAL CONDITION

MSB														LSB	
D15	D14	D13	D12	D11	D10	D9	D8	D7	D6	D5	D4	D3	D2	D1	D0
0	0	0	0	0	0	0	0	0	0	0	0	0	*	*	*
0	0	0	0	0	0	0	0	0	0	0	1	0	*	*	*
0	0	0	0	0	0	0	0	0	0	1	0	0	*	*	*
0	0	0	0	0	0	0	0	0	0	1	1	0	*	*	*
0	0	0	0	0	0	0	0	0	1	0	0	0	*	*	*

Note.) This product starts up by MUTE setting in power “ON”. Use it after removing MUTE of each setting.
 If any audio signal is inputted in input signal terminal before power “ON”, it may cause initial condition abnormality.
 In conditions of use such as the above, it prevents that abnormality by setting MUTE before power “OFF”

■ DEFINITION OF RESISTOR

Volume Control (Att.) : 0dB to -111.5dB / 0.5dBstep.

: Lch Volume and Rch Volume are controlled independently when L/R Cont 1 = "0".

D15	D14	D13	D12	D11	D10	D9	D8	D7	D6	D5	D4	D3	D2	D1	D0
Lch Volume Control (Att.)								0	0	0	0	*	*	*	*
Rch Volume Control (Att.)								0	0	1	0	*	*	*	*

< Volume Control Data >

Data								Setting
D15	D14	D13	D12	D11	D10	D9	D8	
0	0	0	0	0	0	0	0	Mute ⁽¹⁾
0	0	0	1	0	0	0	0	0dB
0	0	0	1	0	0	0	1	-0.5dB
0	0	0	1	0	0	1	0	-1.0dB
0	0	0	1	0	0	1	1	-1.5dB
0	0	0	1	0	1	0	0	-2.0dB
0	0	0	1	0	1	0	1	-2.5dB
0	0	0	1	0	1	1	0	-3.0dB
0	0	0	1	0	1	1	1	-3.5dB
0	0	0	1	1	0	0	0	-4.0dB
0	0	0	1	1	0	0	1	-4.5dB
0	0	0	1	1	0	1	0	-5.0dB
0	0	0	1	1	0	1	1	-5.5dB
0	0	0	1	1	1	0	0	-6.0dB
0	0	0	1	1	1	0	1	-6.5dB
0	0	0	1	1	1	1	0	-7.0dB
0	0	0	1	1	1	1	1	-7.5dB
0	0	1	0	0	0	0	0	-8.0dB
0	0	1	0	0	0	0	1	-8.5dB
0	0	1	0	0	0	1	0	-9.0dB
0	0	1	0	0	0	1	1	-9.5dB
0	0	1	0	0	1	0	0	-10.0dB
0	0	1	0	0	1	0	1	-10.5dB
0	0	1	0	0	1	1	0	-11.0dB
0	0	1	0	0	1	1	1	-11.5dB
0	0	1	0	1	0	0	0	-12.0dB
0	0	1	0	1	0	0	1	-12.5dB
0	0	1	0	1	0	1	0	-13.0dB
0	0	1	0	1	0	1	1	-13.5dB
0	0	1	0	1	1	0	0	-14.0dB
0	0	1	0	1	1	0	1	-14.5dB
0	0	1	0	1	1	1	0	-15.0dB
0	0	1	0	1	1	1	1	-15.5dB
0	0	1	1	0	0	0	0	-16.0dB
0	0	1	1	0	0	0	1	-16.5dB
0	0	1	1	0	0	1	0	-17.0dB
0	0	1	1	0	0	1	1	-17.5dB
0	0	1	1	0	1	0	0	-18.0dB
0	0	1	1	0	1	0	1	-18.5dB
0	0	1	1	0	1	1	0	-19.0dB
0	0	1	1	0	1	1	1	-19.5dB
0	0	1	1	1	0	0	0	-20.0dB
0	0	1	1	1	0	0	1	-20.5dB
0	0	1	1	1	0	1	0	-21.0dB
0	0	1	1	1	0	1	1	-21.5dB
0	0	1	1	1	1	0	0	-22.0dB
0	0	1	1	1	1	0	1	-22.5dB
0	0	1	1	1	1	1	0	-23.0dB
0	0	1	1	1	1	1	1	-23.5dB

< Volume Control Data >

Data								Setting
D15	D14	D13	D12	D11	D10	D9	D8	
0	1	0	0	0	0	0	0	-24.0dB
0	1	0	0	0	0	0	1	-24.5dB
0	1	0	0	0	0	1	0	-25.0dB
0	1	0	0	0	0	1	1	-25.5dB
0	1	0	0	0	1	0	0	-26.0dB
0	1	0	0	0	1	0	1	-26.5dB
0	1	0	0	0	1	1	0	-27.0dB
0	1	0	0	0	1	1	1	-27.5dB
0	1	0	0	1	0	0	0	-28.0dB
0	1	0	0	1	0	0	1	-28.5dB
0	1	0	0	1	0	1	0	-29.0dB
0	1	0	0	1	0	1	1	-29.5dB
0	1	0	0	1	1	0	0	-30.0dB
0	1	0	0	1	1	0	1	-30.5dB
0	1	0	0	1	1	1	0	-31.0dB
0	1	0	0	1	1	1	1	-31.5dB
0	1	0	1	0	0	0	0	-32.0dB
0	1	0	1	0	0	0	1	-32.5dB
0	1	0	1	0	0	1	0	-33.0dB
0	1	0	1	0	0	1	1	-33.5dB
0	1	0	1	0	1	0	0	-34.0dB
0	1	0	1	0	1	0	1	-34.5dB
0	1	0	1	0	1	1	0	-35.0dB
0	1	0	1	0	1	1	1	-35.5dB
0	1	0	1	1	0	0	0	-36.0dB
0	1	0	1	1	0	0	1	-36.5dB
0	1	0	1	1	0	1	0	-37.0dB
0	1	0	1	1	0	1	1	-37.5dB
0	1	0	1	1	1	0	0	-38.0dB
0	1	0	1	1	1	0	1	-38.5dB
0	1	0	1	1	1	1	0	-39.0dB
0	1	0	1	1	1	1	1	-39.5dB
0	1	1	0	0	0	0	0	-40.0dB
0	1	1	0	0	0	0	1	-40.5dB
0	1	1	0	0	0	1	0	-41.0dB
0	1	1	0	0	0	1	1	-41.5dB
0	1	1	0	0	1	0	0	-42.0dB
0	1	1	0	0	1	0	1	-42.5dB
0	1	1	0	0	1	1	0	-43.0dB
0	1	1	0	0	1	1	1	-43.5dB
0	1	1	0	1	0	0	0	-44.0dB
0	1	1	0	1	0	0	1	-44.5dB
0	1	1	0	1	0	1	0	-45.0dB
0	1	1	0	1	0	1	1	-45.5dB
0	1	1	0	1	1	0	0	-46.0dB
0	1	1	0	1	1	0	1	-46.5dB
0	1	1	0	1	1	1	0	-47.0dB
0	1	1	0	1	1	1	1	-47.5dB

< Volume Control Data >

Data								Setting
D15	D14	D13	D12	D11	D10	D9	D8	
0	1	1	1	0	0	0	0	-48.0dB
0	1	1	1	0	0	0	1	-48.5dB
0	1	1	1	0	0	1	0	-49.0dB
0	1	1	1	0	0	1	1	-49.5dB
0	1	1	1	0	1	0	0	-50.0dB
0	1	1	1	0	1	0	1	-50.5dB
0	1	1	1	0	1	1	0	-51.0dB
0	1	1	1	0	1	1	1	-51.5dB
0	1	1	1	1	0	0	0	-52.0dB
0	1	1	1	1	0	0	1	-52.5dB
0	1	1	1	1	0	1	0	-53.0dB
0	1	1	1	1	0	1	1	-53.5dB
0	1	1	1	1	1	0	0	-54.0dB
0	1	1	1	1	1	0	1	-54.5dB
0	1	1	1	1	1	1	0	-55.0dB
0	1	1	1	1	1	1	1	-55.5dB
1	0	0	0	0	0	0	0	-56.0dB
1	0	0	0	0	0	0	1	-56.5dB
1	0	0	0	0	0	1	0	-57.0dB
1	0	0	0	0	0	1	1	-57.5dB
1	0	0	0	0	1	0	0	-58.0dB
1	0	0	0	0	1	0	1	-58.5dB
1	0	0	0	0	1	1	0	-59.0dB
1	0	0	0	0	1	1	1	-59.5dB
1	0	0	0	1	0	0	0	-60.0dB
1	0	0	0	1	0	0	1	-60.5dB
1	0	0	0	1	0	1	0	-61.0dB
1	0	0	0	1	0	1	1	-61.5dB
1	0	0	0	1	1	0	0	-62.0dB
1	0	0	0	1	1	0	1	-62.5dB
1	0	0	0	1	1	1	0	-63.0dB
1	0	0	0	1	1	1	1	-63.5dB
1	0	0	1	0	0	0	0	-64.0dB
1	0	0	1	0	0	0	1	-64.5dB
1	0	0	1	0	0	1	0	-65.0dB
1	0	0	1	0	0	1	1	-65.5dB
1	0	0	1	0	1	0	0	-66.0dB
1	0	0	1	0	1	0	1	-66.5dB
1	0	0	1	0	1	1	0	-67.0dB
1	0	0	1	0	1	1	1	-67.5dB
1	0	0	1	1	0	0	0	-68.0dB
1	0	0	1	1	0	0	1	-68.5dB
1	0	0	1	1	0	1	0	-69.0dB
1	0	0	1	1	0	1	1	-69.5dB
1	0	0	1	1	1	0	0	-70.0dB
1	0	0	1	1	1	0	1	-70.5dB
1	0	0	1	1	1	1	0	-71.0dB
1	0	0	1	1	1	1	1	-71.5dB

< Volume Control Data >

Data								Setting
D15	D14	D13	D12	D11	D10	D9	D8	
1	0	1	0	0	0	0	0	-72.0dB
1	0	1	0	0	0	0	1	-72.5dB
1	0	1	0	0	0	1	0	-73.0dB
1	0	1	0	0	0	1	1	-73.5dB
1	0	1	0	0	1	0	0	-74.0dB
1	0	1	0	0	1	0	1	-74.5dB
1	0	1	0	0	1	1	0	-75.0dB
1	0	1	0	0	1	1	1	-75.5dB
1	0	1	0	1	0	0	0	-76.0dB
1	0	1	0	1	0	0	1	-76.5dB
1	0	1	0	1	0	1	0	-77.0dB
1	0	1	0	1	0	1	1	-77.5dB
1	0	1	0	1	1	0	0	-78.0dB
1	0	1	0	1	1	0	1	-78.5dB
1	0	1	0	1	1	1	0	-79.0dB
1	0	1	0	1	1	1	1	-79.5dB
1	0	1	1	0	0	0	0	-80.0dB
1	0	1	1	0	0	0	1	-80.5dB
1	0	1	1	0	0	1	0	-81.0dB
1	0	1	1	0	0	1	1	-81.5dB
1	0	1	1	0	1	0	0	-82.0dB
1	0	1	1	0	1	0	1	-82.5dB
1	0	1	1	0	1	1	0	-83.0dB
1	0	1	1	0	1	1	1	-83.5dB
1	0	1	1	1	0	0	0	-84.0dB
1	0	1	1	1	0	0	1	-84.5dB
1	0	1	1	1	0	1	0	-85.0dB
1	0	1	1	1	0	1	1	-85.5dB
1	0	1	1	1	1	0	0	-86.0dB
1	0	1	1	1	1	0	1	-86.5dB
1	0	1	1	1	1	1	0	-87.0dB
1	0	1	1	1	1	1	1	-87.5dB
1	1	0	0	0	0	0	0	-88.0dB
1	1	0	0	0	0	0	1	-88.5dB
1	1	0	0	0	0	1	0	-89.0dB
1	1	0	0	0	0	1	1	-89.5dB
1	1	0	0	0	1	0	0	-90.0dB
1	1	0	0	0	1	0	1	-90.5dB
1	1	0	0	0	1	1	0	-91.0dB
1	1	0	0	0	1	1	1	-91.5dB
1	1	0	0	1	0	0	0	-92.0dB
1	1	0	0	1	0	0	1	-92.5dB
1	1	0	0	1	0	1	0	-93.0dB
1	1	0	0	1	0	1	1	-93.5dB
1	1	0	0	1	1	0	0	-94.0dB
1	1	0	0	1	1	0	1	-94.5dB
1	1	0	0	1	1	1	0	-95.0dB
1	1	0	0	1	1	1	1	-95.5dB

< Volume Control Data >

Data								Setting
D15	D14	D13	D12	D11	D10	D9	D8	
1	1	0	1	0	0	0	0	-96.0dB
1	1	0	1	0	0	0	1	-96.5dB
1	1	0	1	0	0	1	0	-97.0dB
1	1	0	1	0	0	1	1	-97.5dB
1	1	0	1	0	1	0	0	-98.0dB
1	1	0	1	0	1	0	1	-98.5dB
1	1	0	1	0	1	1	0	-99.0dB
1	1	0	1	0	1	1	1	-99.5dB
1	1	0	1	1	0	0	0	-100.0dB
1	1	0	1	1	0	0	1	-100.5dB
1	1	0	1	1	0	1	0	-101.0dB
1	1	0	1	1	0	1	1	-101.5dB
1	1	0	1	1	1	0	0	-102.0dB
1	1	0	1	1	1	0	1	-102.5dB
1	1	0	1	1	1	1	0	-103.0dB
1	1	0	1	1	1	1	1	-103.5dB
1	1	1	0	0	0	0	0	-104.0dB
1	1	1	0	0	0	0	1	-104.5dB
1	1	1	0	0	0	1	0	-105.0dB
1	1	1	0	0	0	1	1	-105.5dB
1	1	1	0	0	1	0	0	-106.0dB
1	1	1	0	0	1	0	1	-106.5dB
1	1	1	0	0	1	1	0	-107.0dB
1	1	1	0	0	1	1	1	-107.5dB
1	1	1	0	1	0	0	0	-108.0dB
1	1	1	0	1	0	0	1	-108.5dB
1	1	1	0	1	0	1	0	-109.0dB
1	1	1	0	1	0	1	1	-109.5dB
1	1	1	0	1	1	0	0	-110.0dB
1	1	1	0	1	1	0	1	-110.5dB
1	1	1	0	1	1	1	0	-111.0dB
1	1	1	0	1	1	1	1	-111.5dB
1	1	1	1	1	1	1	1	Mute

ⒸInitial Setting

Volume Control (Gain.) : +31.5dB to 0dB / 0.5dBstep.
 : Lch Volume and Rch Volume are controlled independently when L/R Cont 2 = "0".

D15	D14	D13	D12	D11	D10	D9	D8	D7	D6	D5	D4	D3	D2	D1	D0
0	Lch Volume Control (Gain)							0	0	0	1	0	*	*	*
0	Rch Volume Control (Gain)							0	0	1	1	0	*	*	*

< Volume Control Data >

Data							Setting
D14	D13	D12	D11	D10	D9	D8	
0	0	0	0	0	0	0	0dB(+)
1	0	0	0	0	0	0	+0.25dB
0	0	0	0	0	0	1	+0.5dB
0	0	0	0	0	1	0	+1.0dB
0	0	0	0	0	1	1	+1.5dB
0	0	0	0	1	0	0	+2.0dB
0	0	0	0	1	0	1	+2.5dB
0	0	0	0	1	1	0	+3.0dB
0	0	0	0	1	1	1	+3.5dB
0	0	0	1	0	0	0	+4.0dB
0	0	0	1	0	0	1	+4.5dB
0	0	0	1	0	1	0	+5.0dB
0	0	0	1	0	1	1	+5.5dB
0	0	0	1	1	0	0	+6.0dB
0	0	0	1	1	0	1	+6.5dB
0	0	0	1	1	1	0	+7.0dB
0	0	0	1	1	1	1	+7.5dB
0	0	1	0	0	0	0	+8.0dB
1	0	1	0	0	0	0	+8.25dB
0	0	1	0	0	0	1	+8.5dB
0	0	1	0	0	1	0	+9.0dB
0	0	1	0	0	1	1	+9.5dB
0	0	1	0	1	0	0	+10.0dB
0	0	1	0	1	0	1	+10.5dB
0	0	1	0	1	1	0	+11.0dB
0	0	1	0	1	1	1	+11.5dB
0	0	1	1	0	0	0	+12.0dB
0	0	1	1	0	0	1	+12.5dB
0	0	1	1	0	1	0	+13.0dB
0	0	1	1	0	1	1	+13.5dB
0	0	1	1	1	0	0	+14.0dB
0	0	1	1	1	0	1	+14.5dB
0	0	1	1	1	1	0	+15.0dB
0	0	1	1	1	1	1	+15.5dB
0	1	0	0	0	0	0	+16.0dB
1	1	0	0	0	0	0	+16.25dB
0	1	0	0	0	0	1	+16.5dB
0	1	0	0	0	1	0	+17.0dB
0	1	0	0	0	1	1	+17.5dB
0	1	0	0	1	0	0	+18.0dB
0	1	0	0	1	0	1	+18.5dB
0	1	0	0	1	1	0	+19.0dB
0	1	0	0	1	1	1	+19.5dB
0	1	0	1	0	0	0	+20.0dB
0	1	0	1	0	0	1	+20.5dB
0	1	0	1	0	1	0	+21.0dB
0	1	0	1	0	1	1	+21.5dB
0	1	0	1	1	0	0	+22.0dB
0	1	0	1	1	0	1	+22.5dB
0	1	0	1	1	1	0	+23.0dB
0	1	0	1	1	1	1	+23.5dB

< Volume Control Data >

Data							Setting
D14	D13	D12	D11	D10	D9	D8	
0	1	1	0	0	0	0	+24.0dB
1	1	1	0	0	0	0	+24.25dB
0	1	1	0	0	0	1	+24.5dB
0	1	1	0	0	1	0	+25.0dB
0	1	1	0	0	1	1	+25.5dB
0	1	1	0	1	0	0	+26.0dB
0	1	1	0	1	0	1	+26.5dB
0	1	1	0	1	1	0	+27.0dB
0	1	1	0	1	1	1	+27.5dB
0	1	1	1	0	0	0	+28.0dB
0	1	1	1	0	0	1	+28.5dB
0	1	1	1	0	1	0	+29.0dB
0	1	1	1	0	1	1	+29.5dB
0	1	1	1	1	0	0	+30.0dB
0	1	1	1	1	0	1	+30.5dB
0	1	1	1	1	1	0	+31.0dB
0	1	1	1	1	1	1	+31.5dB

(b) Initial Setting

L/R Cont 1 : Select " the independent control" or " the Lch-Rch link control" of the method of the volume control (Att).
L/R Cont 2 : Select " the independent control" or " the Lch-Rch link control" of the method of the volume control (Gain).
Z/C : Zero Cross Detection circuit ON/OFF setting

D15	D14	D13	D12	D11	D10	D9	D8	D7	D6	D5	D4	D3	D2	D1	D0
L/R Cont 1	L/R Cont 2	Z/C	Don't Care	Don't Care	Don't Care	Don't Care	Don't Care	0	1	0	0	0	*	*	*

<L/R Cont 1 : Method of the volume control (Att).>

D15	Setting
0	Lch, Rch independent control ⁽¹⁾
1	Lch-Rch link control

⁽¹⁾Initial Setting

<L/R Cont 2 : Method of the volume control (Gain).>

D14	Setting
0	Lch, Rch independent control ⁽¹⁾
1	Lch-Rch link control

⁽¹⁾Initial Setting

* Command table when Lch, Rch interconnected control

D15	D14	D13	D12	D11	D10	D9	D8	D7	D6	D5	D4	D3	D2	D1	D0
Lch-Rch link control (Att.)								0	0	0	0	0	*	*	*
Lch-Rch link control (Gain)								0	0	0	1	0	*	*	*
No Acceptable								0	0	1	0	0	*	*	*
No Acceptable								0	0	1	1	0	*	*	*

<Z/C : Zero Cross Detection circuit ON/OFF setting >

D13	Setting
0	Zero Cross Detection circuit: ON ⁽¹⁾
1	Zero Cross Detection circuit: OFF

⁽¹⁾Initial Setting

* Zero cross detection circuit is ON When "Z/C terminal = Low" and "Z/C bit =0" are set.

		Z/C bit ("D13")	
		0	1
Z/C terminal (32pin)	Low	Zero Cross Detection circuit : ON	Zero Cross Detection circuit : OFF
	High	Zero Cross Detection circuit : OFF	Zero Cross Detection circuit : OFF

Volume Control (Att) +0.25dB to -111.5dB(0.25dB/step) setting example

Using Volume Control(Gain) +0.25dB enables to set 0.25dB/step in the range of +0.25dB to -111.5dB.
 (+8.25dB, +16.25,+24.25 also can be used)

< Volume Control Data >

Lch / Rch Volume Control (Gain)							Lch / Rch Volume Control (Att)							Gain Setting	
D14	D13	D12	D11	D10	D9	D8	D15	D14	D13	D12	D11	D10	D9	D8	
0	1	1	1	1	1	1	0	0	0	1	0	0	0	0	+31.5dB
0	1	1	1	1	1	0	0	0	0	1	0	0	0	0	+31.0dB
0	1	1	1	1	0	1	0	0	0	1	0	0	0	0	+30.5dB
0	1	1	1	1	0	0	0	0	0	1	0	0	0	0	+30.0dB
0	1	1	1	0	1	1	0	0	0	1	0	0	0	0	+29.5dB
0	1	1	1	0	1	0	0	0	0	1	0	0	0	0	+29.0dB
0	1	1	1	0	0	1	0	0	0	1	0	0	0	0	+28.5dB
0	1	1	1	0	0	0	0	0	0	1	0	0	0	0	+28.0dB
0	1	1	0	1	1	1	0	0	0	1	0	0	0	0	+27.5dB
0	1	1	0	1	1	0	0	0	0	1	0	0	0	0	+27.0dB
			:							:					:
			:							:					:
0	0	0	0	1	0	0	0	0	0	1	0	0	0	0	+2.0dB
0	0	0	0	0	1	1	0	0	0	1	0	0	0	0	+1.5dB
0	0	0	0	0	1	0	0	0	0	1	0	0	0	0	+1.0dB
0	0	0	0	0	0	1	0	0	0	1	0	0	0	0	+0.5dB
1	0	0	0	0	0	0	0	0	0	1	0	0	0	0	+0.25dB
0	0	0	0	0	0	0	0	0	0	1	0	0	0	0	+0dB
1	0	0	0	0	0	0	0	0	0	1	0	0	0	1	-0.25dB
0	0	0	0	0	0	0	0	0	0	1	0	0	0	1	-0.5dB
1	0	0	0	0	0	0	0	0	0	1	0	0	1	0	-0.75dB
0	0	0	0	0	0	0	0	0	0	1	0	0	1	0	-1.0dB
1	0	0	0	0	0	0	0	0	0	1	0	0	1	1	-1.25dB
0	0	0	0	0	0	0	0	0	0	1	0	0	1	1	-1.5dB
1	0	0	0	0	0	0	0	0	0	1	0	1	0	0	-1.75dB
0	0	0	0	0	0	0	0	0	0	1	0	1	0	0	-2.0dB
1	0	0	0	0	0	0	0	0	0	1	0	1	0	1	-2.25dB
0	0	0	0	0	0	0	0	0	0	1	0	1	0	1	-2.5dB
1	0	0	0	0	0	0	0	0	0	1	0	1	1	0	-2.75dB
0	0	0	0	0	0	0	0	0	0	1	0	1	1	0	-3.0dB
1	0	0	0	0	0	0	0	0	0	1	0	1	1	1	-3.25dB
0	0	0	0	0	0	0	0	0	0	1	0	1	1	1	-3.5dB
1	0	0	0	0	0	0	0	0	0	1	1	0	0	0	-3.75dB
0	0	0	0	0	0	0	0	0	0	1	1	0	0	0	-4.0dB
1	0	0	0	0	0	0	0	0	0	1	1	0	0	1	-4.25dB
0	0	0	0	0	0	0	0	0	0	1	1	0	0	1	-4.5dB
1	0	0	0	0	0	0	0	0	0	1	1	0	1	0	-4.75dB
0	0	0	0	0	0	0	0	0	0	1	1	0	1	0	-5.0dB
1	0	0	0	0	0	0	0	0	0	1	1	0	1	1	-5.25dB
0	0	0	0	0	0	0	0	0	0	1	1	0	1	1	-5.5dB
1	0	0	0	0	0	0	0	0	0	1	1	1	0	0	-5.75dB
0	0	0	0	0	0	0	0	0	0	1	1	1	0	0	-6.0dB
			:							:					:
			:							:					:
1	0	0	0	0	0	0	1	1	1	0	1	1	0	1	-110.25dB
0	0	0	0	0	0	0	1	1	1	0	1	1	0	1	-110.5dB
1	0	0	0	0	0	0	1	1	1	0	1	1	1	0	-110.75dB
0	0	0	0	0	0	0	1	1	1	0	1	1	1	0	-111.0dB
1	0	0	0	0	0	0	1	1	1	0	1	1	1	1	-111.25dB
0	0	0	0	0	0	0	1	1	1	0	1	1	1	1	-111.5dB
0	0	0	0	0	0	0	1	1	1	1	1	1	1	1	Mute

■ TYPICAL CHARACTERISTICS

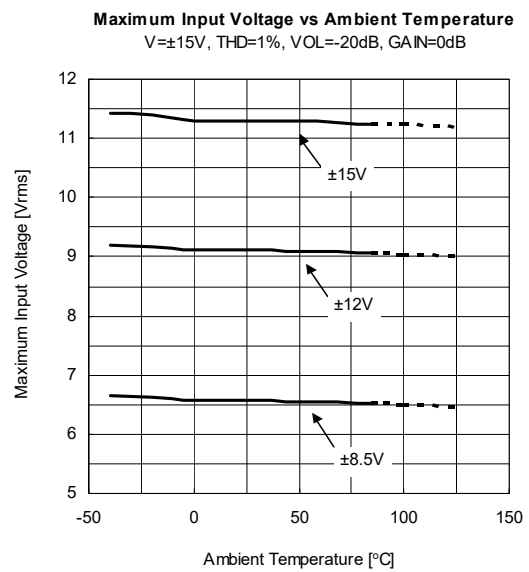
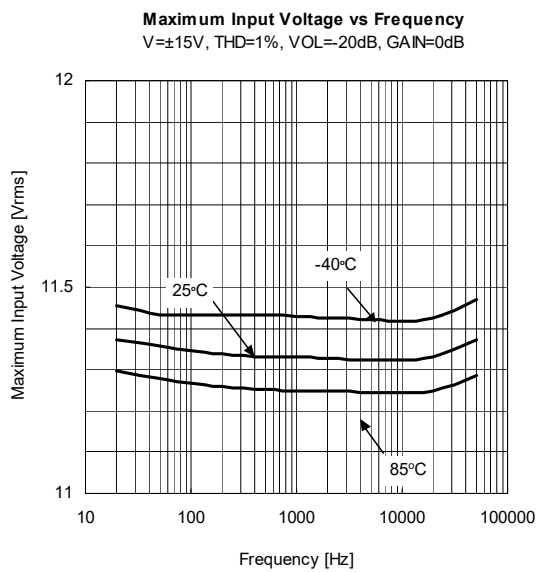
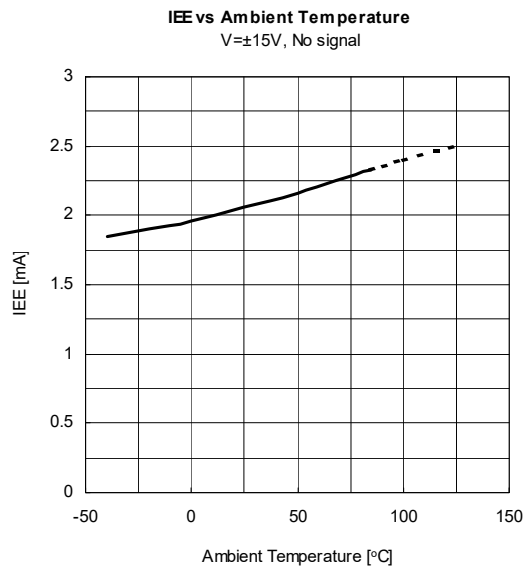
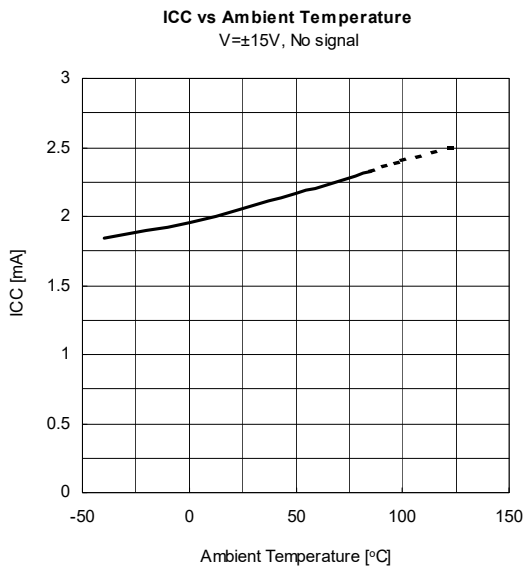
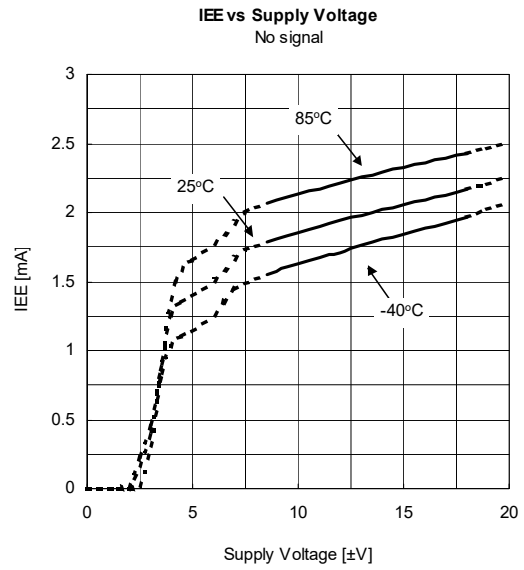
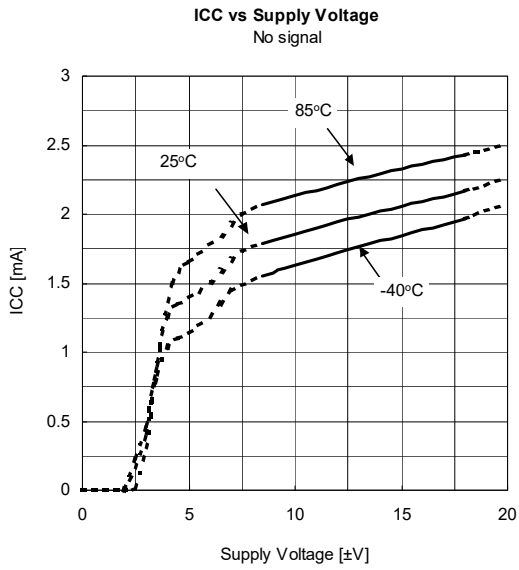

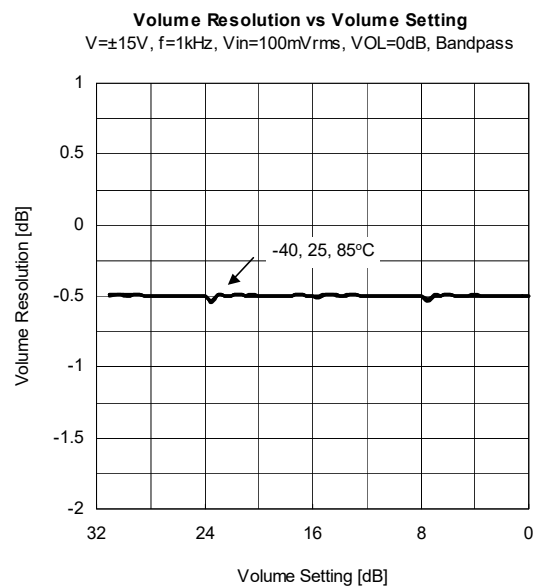
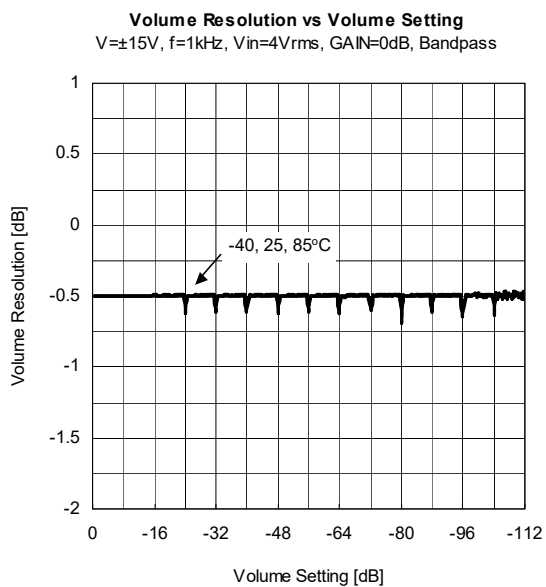
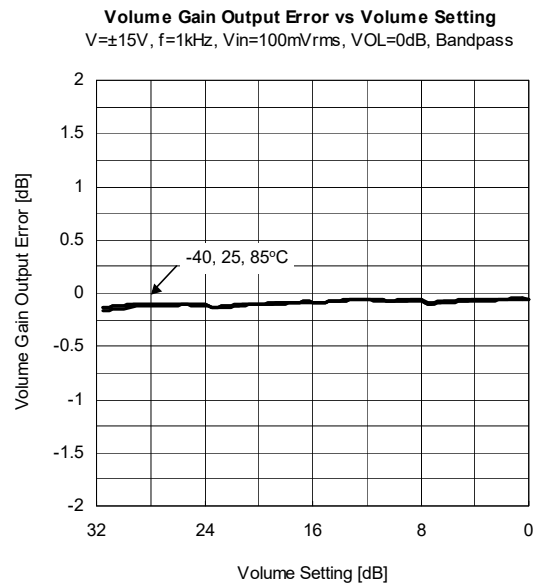
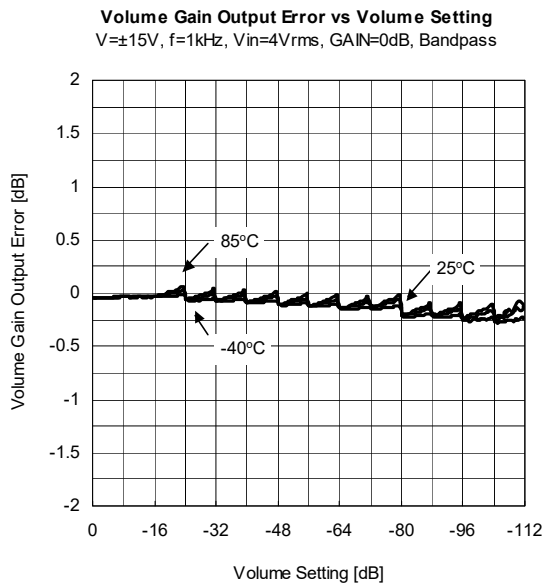
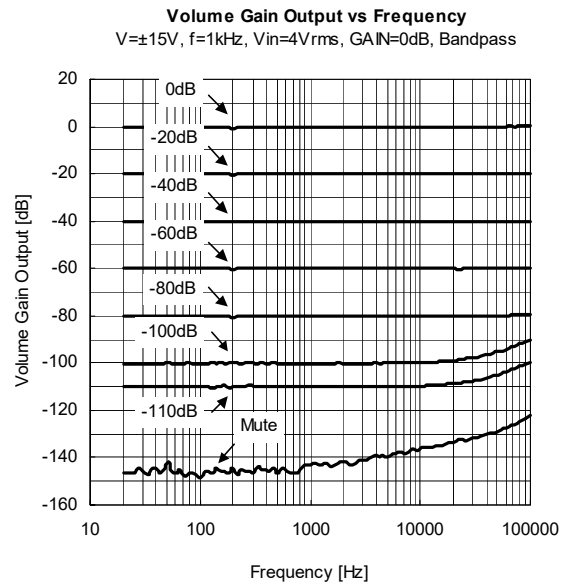
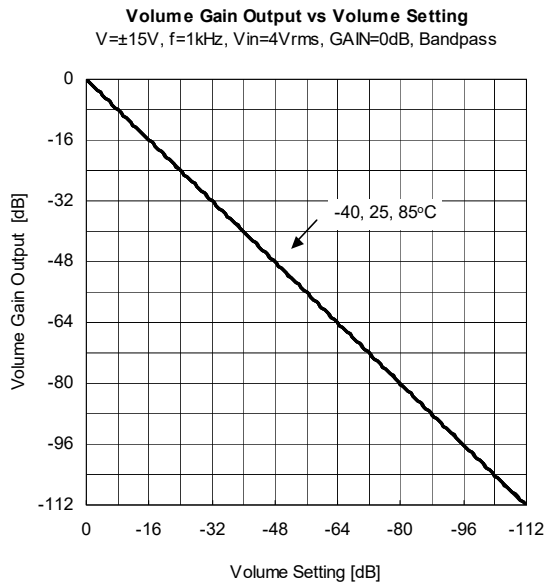

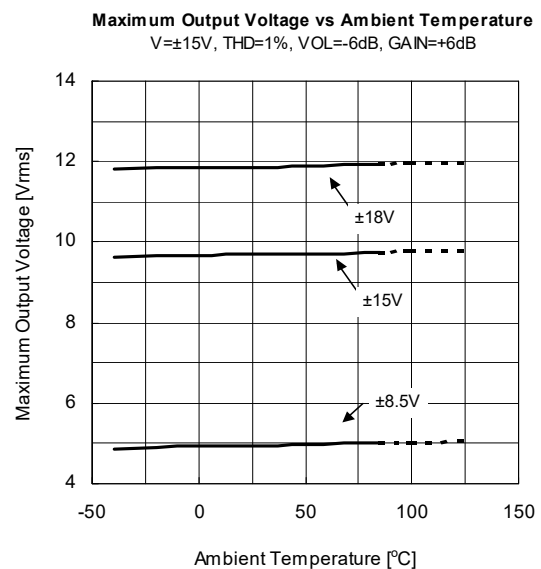
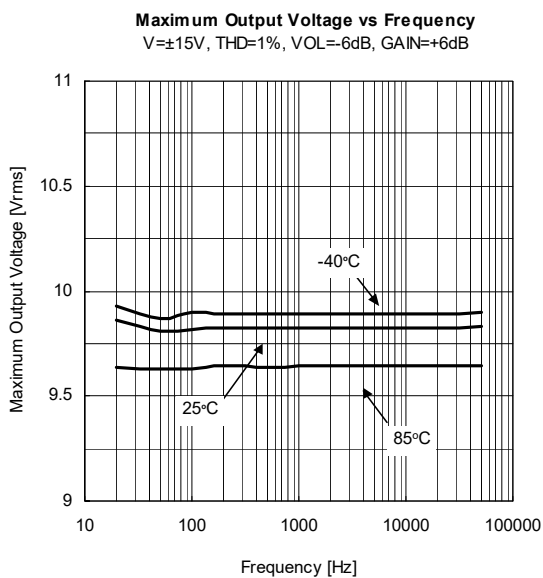
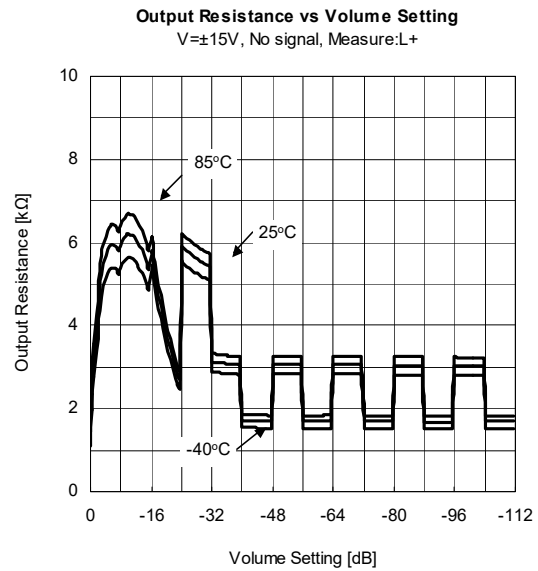
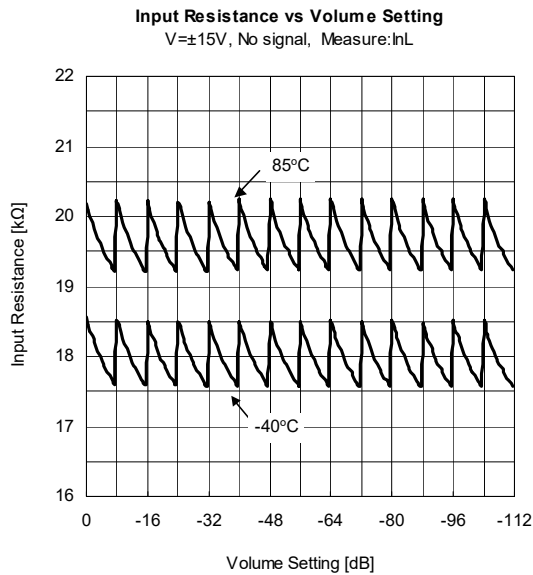
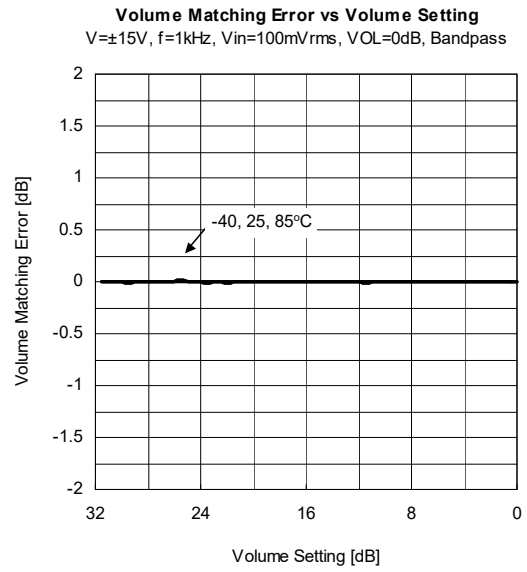
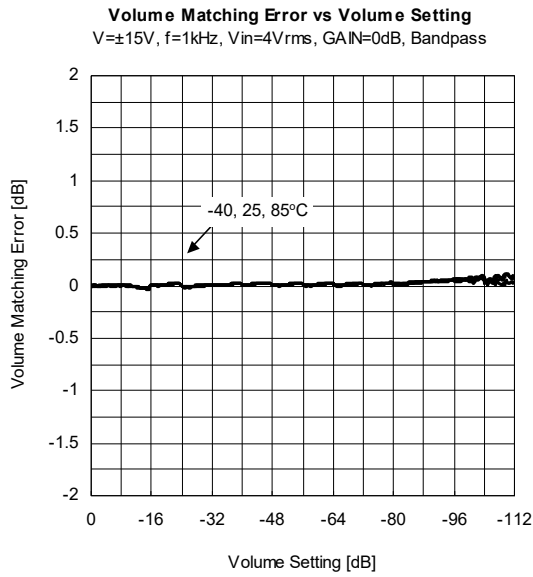

■ REVISION HISTORY

Date	Revision	Changes
May 27, 2025	Ver. 2.0	<ul style="list-style-type: none">• Change of company name and design form• Revision number (Ver.1.1E → Ver.2.0)• Added revision history

■ HEAT-RESISTANCE PROFILES

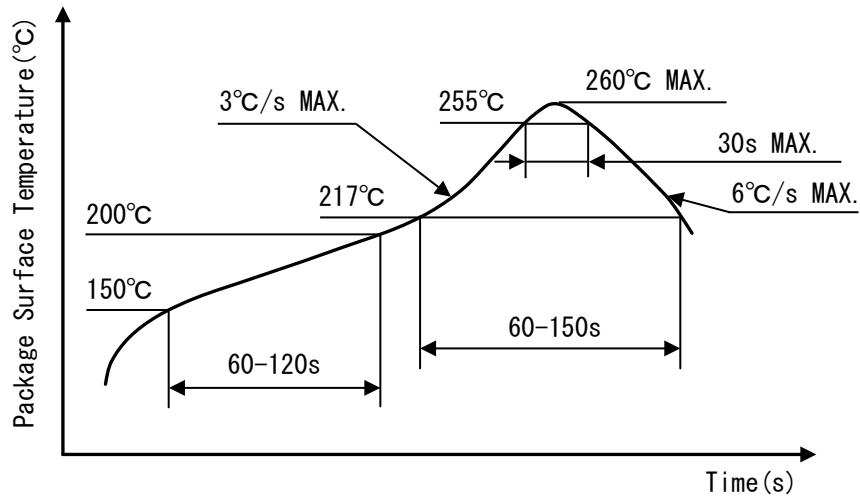

Reflow profile

■ PACKAGE DIMENSIONS

UNIT: mm

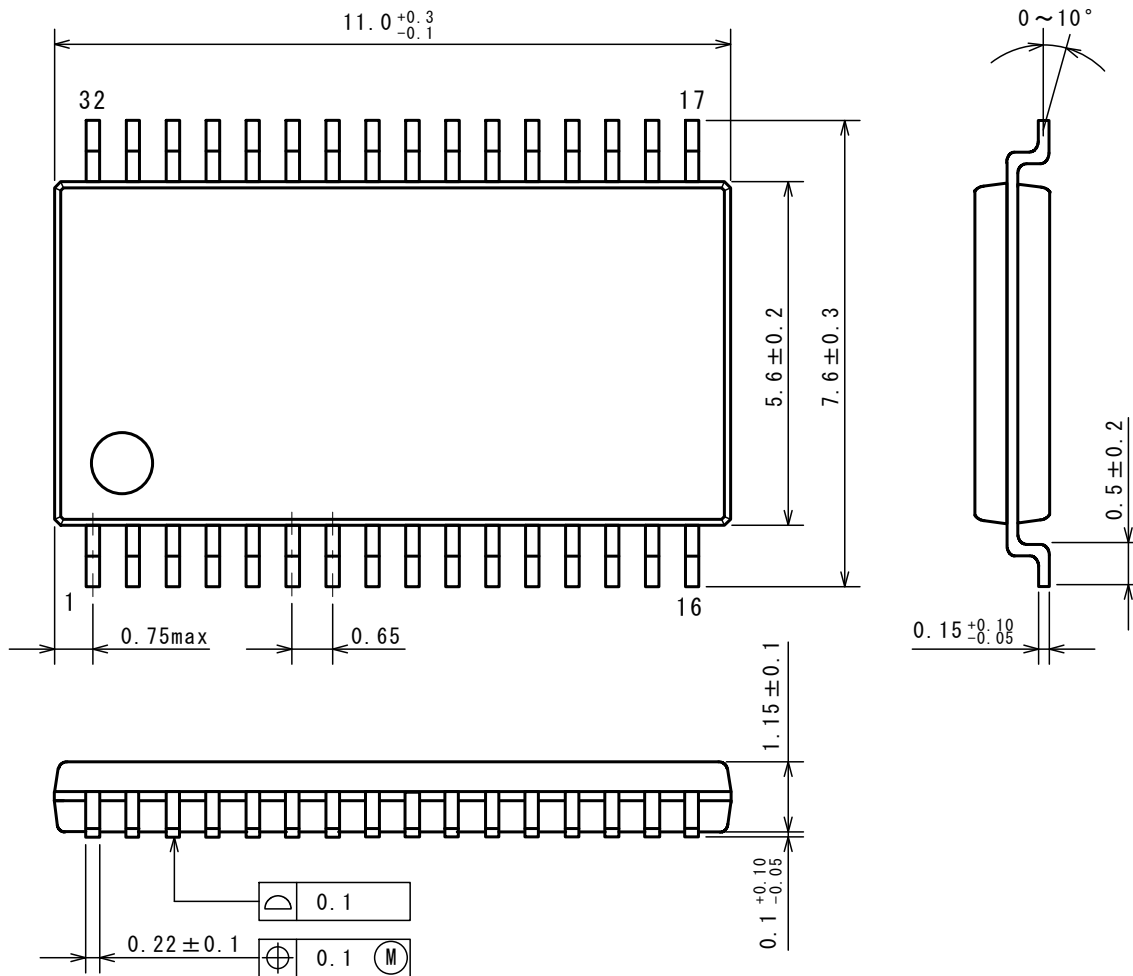

■ EXAMPLE OF SOLDER PADS DIMENSIONS

UNIT: mm

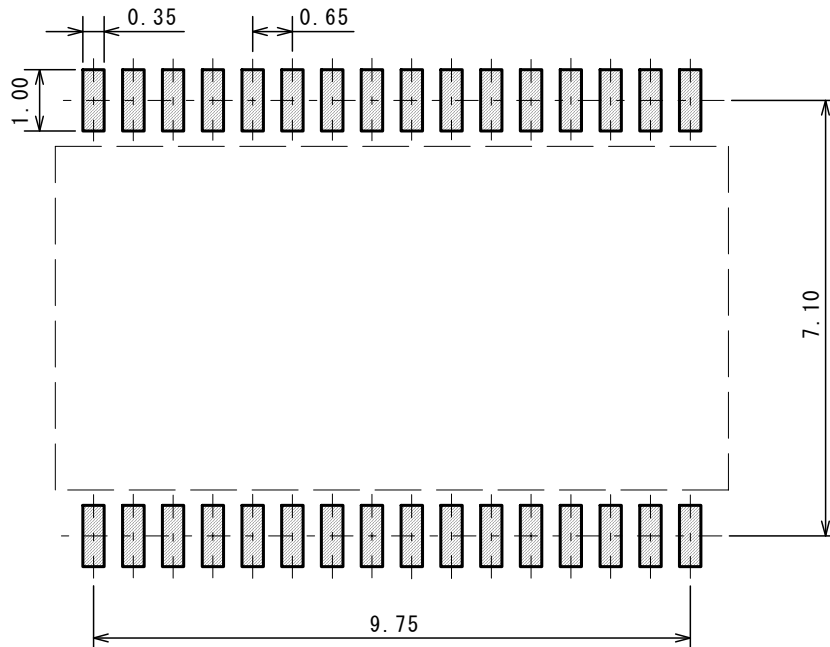

Nisshinbo Micro Devices Inc.

SSOP32

PI-SSOP32-E-B

■ PACKING SPEC

UNIT: mm

TAPING DIMENSIONS

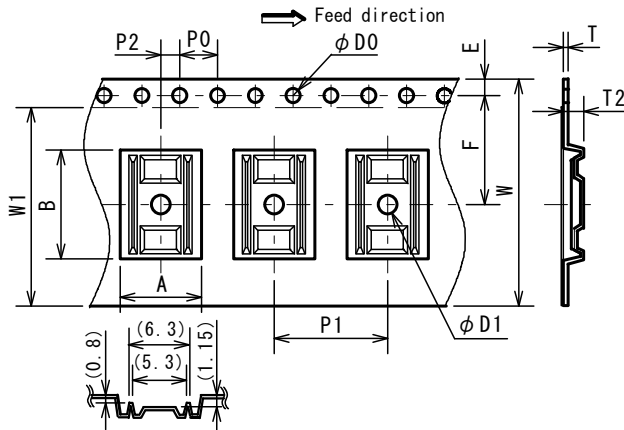

SYMBOL	DIMENSION	REMARKS
A	8.6±0.1	BOTTOM DIMENSION
B	11.5±0.1	BOTTOM DIMENSION
D0	1.5 ^{+0.1} ₀	
D1	2.0 ^{+0.1} ₀	
E	1.75±0.1	
F	11.5±0.01	
P0	4.0±0.1	
P1	12.0±0.1	
P2	2.0±0.1	
T	0.3±0.05	
T2	2.1±0.1	
W	24.0±0.3	
W1	21.0±0.1	THICKNESS 0.1max

REEL DIMENSIONS

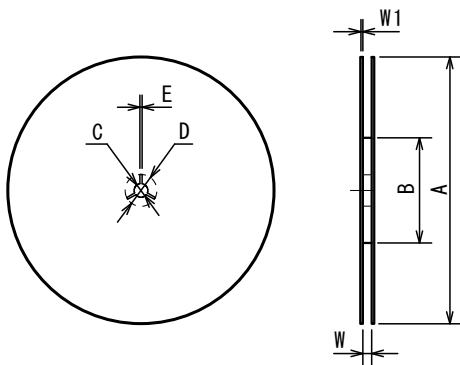

SYMBOL	DIMENSION
A	φ 330±2
B	φ 80±1
C	φ 13±0.5
D	φ 21±0.8
E	2±0.5
W	25.5±1.0
W1	2

TAPING STATE

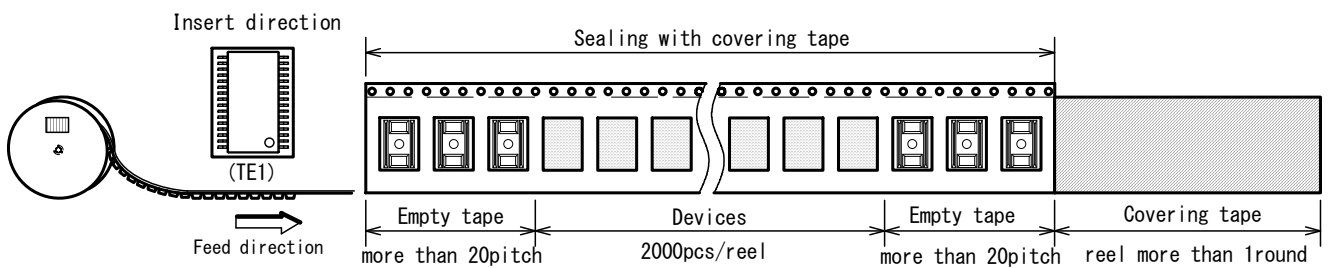

PACKING STATE

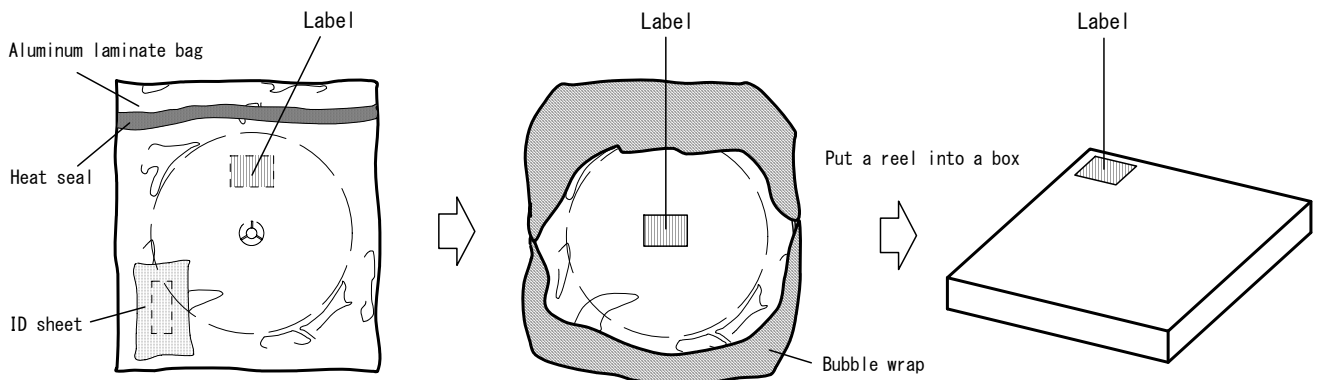

1. The products and the product specifications described in this document are subject to change or discontinuation of production without notice for reasons such as improvement. Therefore, before deciding to use the products, please refer to our sales representatives for the latest information thereon.
2. The materials in this document may not be copied or otherwise reproduced in whole or in part without the prior written consent of us.
3. This product and any technical information relating thereto are subject to complementary export controls (so-called KNOW controls) under the Foreign Exchange and Foreign Trade Law, and related politics ministerial ordinance of the law. (Note that the complementary export controls are inapplicable to any application-specific products, except rockets and pilotless aircraft, that are insusceptible to design or program changes.) Accordingly, when exporting or carrying abroad this product, follow the Foreign Exchange and Foreign Trade Control Law and its related regulations with respect to the complementary export controls.
4. The technical information described in this document shows typical characteristics and example application circuits for the products. The release of such information is not to be construed as a warranty of or a grant of license under our or any third party's intellectual property rights or any other rights.
5. The products listed in this document are intended and designed for use as general electronic components in standard applications (office equipment, telecommunication equipment, measuring instruments, consumer electronic products, amusement equipment etc.). Those customers intending to use a product in an application requiring extreme quality and reliability, for example, in a highly specific application where the failure or misoperation of the product could result in human injury or death should first contact us.
 - Aerospace Equipment
 - Equipment Used in the Deep Sea
 - Power Generator Control Equipment (nuclear, steam, hydraulic, etc.)
 - Life Maintenance Medical Equipment
 - Fire Alarms / Intruder Detectors
 - Vehicle Control Equipment (automotive, airplane, railroad, ship, etc.)
 - Various Safety Devices
 - Traffic control system
 - Combustion equipment

In case your company desires to use this product for any applications other than general electronic equipment mentioned above, make sure to contact our company in advance. Note that the important requirements mentioned in this section are not applicable to cases where operation requirements such as application conditions are confirmed by our company in writing after consultation with your company.

6. We are making our continuous effort to improve the quality and reliability of our products, but semiconductor products are likely to fail with certain probability. In order to prevent any injury to persons or damages to property resulting from such failure, customers should be careful enough to incorporate safety measures in their design, such as redundancy feature, fire containment feature and fail-safe feature. We do not assume any liability or responsibility for any loss or damage arising from misuse or inappropriate use of the products.
7. The products have been designed and tested to function within controlled environmental conditions. Do not use products under conditions that deviate from methods or applications specified in this datasheet. Failure to employ the products in the proper applications can lead to deterioration, destruction or failure of the products. We shall not be responsible for any bodily injury, fires or accident, property damage or any consequential damages resulting from misuse or misapplication of the products.
8. **Quality Warranty**
 - 8-1. **Quality Warranty Period**

In the case of a product purchased through an authorized distributor or directly from us, the warranty period for this product shall be one (1) year after delivery to your company. For defective products that occurred during this period, we will take the quality warranty measures described in section 8-2. However, if there is an agreement on the warranty period in the basic transaction agreement, quality assurance agreement, delivery specifications, etc., it shall be followed.
 - 8-2. **Quality Warranty Remedies**

When it has been proved defective due to manufacturing factors as a result of defect analysis by us, we will either deliver a substitute for the defective product or refund the purchase price of the defective product.
Note that such delivery or refund is sole and exclusive remedies to your company for the defective product.
 - 8-3. **Remedies after Quality Warranty Period**

With respect to any defect of this product found after the quality warranty period, the defect will be analyzed by us. On the basis of the defect analysis results, the scope and amounts of damage shall be determined by mutual agreement of both parties. Then we will deal with upper limit in Section 8-2. This provision is not intended to limit any legal rights of your company.
9. Anti-radiation design is not implemented in the products described in this document.
10. The X-ray exposure can influence functions and characteristics of the products. Confirm the product functions and characteristics in the evaluation stage.
11. WLCSP products should be used in light shielded environments. The light exposure can influence functions and characteristics of the products under operation or storage.
12. Warning for handling Gallium and Arsenic (GaAs) products (Applying to GaAs MMIC, Photo Reflector). These products use Gallium (Ga) and Arsenic (As) which are specified as poisonous chemicals by law. For the prevention of a hazard, do not burn, destroy, or process chemically to make them as gas or power. When the product is disposed of, please follow the related regulation and do not mix this with general industrial waste or household waste.
13. Please contact our sales representatives should you have any questions or comments concerning the products or the technical information.



Nisshinbo Micro Devices Inc.

Official website

<https://www.nisshinbo-microdevices.co.jp/en/>

Purchase information

<https://www.nisshinbo-microdevices.co.jp/en/buy/>