

U37F Series



- Large Can
- Screw Terminals
- General Purpose U37 Grade
- High Ripple
- 350 to 500VDC Ratings
- RoHS Compliant
- 5,000 Hours Lifetime at +85°C
- Up to 150,000 Hours Useful Life



The U37F series is a general purpose, screw mount U37 grade series specifically designed to provide the ripple current capability and long life required for high reliability inverter applications. The U37F has an endurance rating of 5,000 hours at +85°C with the rated ripple current applied. The useful life can exceed 150,000 hours at +40°C and 1.5x the ripple current. These capacitors are available in a variety of high current English or Metric thread terminals. Mounting options include a three-footed clamp or bottom threaded stud. Custom designs are also available.

Summary of Specifications

- Screw terminals: high and low post, English and Metric thread.
- Capacitance range: 1,500 to 22,000µF.
- Voltage range: 350 to 500VDC.
- Category temperature range: -40°C to +85°C.
- Leakage current: 0.02CV(µA) or 5mA, whichever is smaller, after 5 minutes at +25°C.
- Standard capacitance tolerance: ±20%
- Nominal case size (D×L): D = 50mm (2.000") to 89mm (3.500"); L = 92mm (3.625") to 219mm (8.625").
- Rated lifetime: 5,000 hours at +85°C with rated ripple current applied.



U37F Series

U37F Specifications - Screw Terminals

Item	Characteristics																																															
Category Temperature Range	- 40 to +85°C																																															
Rated Voltage Range	350 to 500VDC																																															
Capacitance Range	1,500 to 22,000µF at +25°C, 120Hz																																															
Capacitance Tolerance	±20% (M) at +25°C, 120Hz																																															
Leakage Current	I = 0.02CV (µA) or 5mA, whichever is smaller, after 5 minutes at +25°C. Where I = Max. leakage current (µA), C = Nominal capacitance (µF) and V = Rated voltage (V)																																															
Rated Ripple Current Multipliers	<p>Ambient Temperature (°C)</p> <table border="1"> <tr> <td>+45°C</td> <td>+65°C</td> <td>+85°C</td> </tr> <tr> <td>2.82</td> <td>1.73</td> <td>1.00</td> </tr> </table> <p>Frequency (Hz)</p> <table border="1"> <tr> <td>DC Rated Voltage</td> <td>50Hz</td> <td>120Hz</td> <td>300Hz</td> <td>1kHz</td> <td>3kHz</td> <td>10kHz</td> </tr> <tr> <td>350-500V</td> <td>0.80</td> <td>1.00</td> <td>1.20</td> <td>1.30</td> <td>1.40</td> <td>1.41</td> </tr> </table> <p>To determine maximum ripple current at a specified temperature and frequency, use the appropriate multiplier shown.</p>	+45°C	+65°C	+85°C	2.82	1.73	1.00	DC Rated Voltage	50Hz	120Hz	300Hz	1kHz	3kHz	10kHz	350-500V	0.80	1.00	1.20	1.30	1.40	1.41																											
+45°C	+65°C	+85°C																																														
2.82	1.73	1.00																																														
DC Rated Voltage	50Hz	120Hz	300Hz	1kHz	3kHz	10kHz																																										
350-500V	0.80	1.00	1.20	1.30	1.40	1.41																																										
Endurance (Load Life)	<p>The following specifications shall be satisfied when the capacitors are restored to +25°C after subjecting them to DC voltage for 5,000 hours at +85°C with the rated ripple current applied. The sum of the DC voltage and peak AC voltage must not exceed the full rated voltage of the capacitors.</p> <p>Capacitance change: ≤ 20% from initial measurement ESR change : ≤ 200% of initial specified limit Leakage current : ≤ initial specified limit</p>																																															
Useful Life	<p>With specified standard voltage and ripple current applied, typical life as function of ambient temperature is listed below.</p> <table border="1"> <tr> <td>+85°C</td> <td>6,500 hours max.</td> </tr> <tr> <td>+65°C</td> <td>23,800 hours max.</td> </tr> <tr> <td>+45°C</td> <td>124,700 hours max.</td> </tr> </table> <p>Capacitance change: ≤ 30% from initial measurement ESR change : ≤ 300% of initial specified limit Leakage current : ≤ initial specified limit</p>	+85°C	6,500 hours max.	+65°C	23,800 hours max.	+45°C	124,700 hours max.																																									
+85°C	6,500 hours max.																																															
+65°C	23,800 hours max.																																															
+45°C	124,700 hours max.																																															
Shelf Life	<p>The following specifications shall be satisfied when the capacitors are restored to +25°C after exposing them for 500 hours at +85°C without voltage applied. The rated voltage shall be applied to the capacitors for a minimum of 30 minutes, at least 24 hours and not more than 48 hours before the measurements.</p> <p>Capacitance change: ≤ 20% from initial measurement ESR change : ≤ 200% of initial specified limit Leakage current : ≤ initial specified limit</p>																																															
Vibration Rating	10-55Hz, 10g sinusoidal in three axes, 2 hours per axis.																																															
Maximum Tightening Torque	<table border="1"> <tr> <td>Terminal Code</td> <td>HP</td> <td>HL</td> <td>CD</td> <td>CP</td> <td>CH</td> <td>CA</td> <td>CS</td> </tr> <tr> <td>Thread Size</td> <td>10-32 NF-2B</td> <td>M5x0.8-6H</td> <td></td> <td>1/4-28 NF-2B</td> <td></td> <td>M6x1-6H</td> <td></td> </tr> <tr> <td>3 Threads Engaged</td> <td colspan="3">2.0 N·m (18.0 in·lb)</td> <td colspan="4">4.0 N·m (35.0 in·lb)</td> </tr> <tr> <td>6 Threads Engaged</td> <td colspan="3">2.8 N·m (25.0 in·lb)</td> <td colspan="4">6.2 N·m (55.0 in·lb)</td> </tr> </table>	Terminal Code	HP	HL	CD	CP	CH	CA	CS	Thread Size	10-32 NF-2B	M5x0.8-6H		1/4-28 NF-2B		M6x1-6H		3 Threads Engaged	2.0 N·m (18.0 in·lb)			4.0 N·m (35.0 in·lb)				6 Threads Engaged	2.8 N·m (25.0 in·lb)			6.2 N·m (55.0 in·lb)																		
Terminal Code	HP	HL	CD	CP	CH	CA	CS																																									
Thread Size	10-32 NF-2B	M5x0.8-6H		1/4-28 NF-2B		M6x1-6H																																										
3 Threads Engaged	2.0 N·m (18.0 in·lb)			4.0 N·m (35.0 in·lb)																																												
6 Threads Engaged	2.8 N·m (25.0 in·lb)			6.2 N·m (55.0 in·lb)																																												
Typical Inductance (nH) at 1MHz	<table border="1"> <tr> <td rowspan="2">Case Diameter (mm)</td> <td colspan="7">Terminal Code</td> </tr> <tr> <td>HP</td> <td>HL</td> <td>CD</td> <td>CP</td> <td>CH</td> <td>CA</td> <td>CS</td> </tr> <tr> <td>∅50.8</td> <td>—</td> <td>—</td> <td>NA</td> <td>NA</td> <td>NA</td> <td>NA</td> <td>NA</td> </tr> <tr> <td>∅63.5</td> <td>—</td> <td>—</td> <td>—</td> <td>—</td> <td>—</td> <td>—</td> <td>—</td> </tr> <tr> <td>∅76.2</td> <td>30</td> <td>30</td> <td>25</td> <td>20</td> <td>25</td> <td>20</td> <td>25</td> </tr> <tr> <td>∅89.0</td> <td>30</td> <td>30</td> <td>25</td> <td>20</td> <td>25</td> <td>20</td> <td>25</td> </tr> </table>	Case Diameter (mm)	Terminal Code							HP	HL	CD	CP	CH	CA	CS	∅50.8	—	—	NA	NA	NA	NA	NA	∅63.5	—	—	—	—	—	—	—	∅76.2	30	30	25	20	25	20	25	∅89.0	30	30	25	20	25	20	25
Case Diameter (mm)	Terminal Code																																															
	HP	HL	CD	CP	CH	CA	CS																																									
∅50.8	—	—	NA	NA	NA	NA	NA																																									
∅63.5	—	—	—	—	—	—	—																																									
∅76.2	30	30	25	20	25	20	25																																									
∅89.0	30	30	25	20	25	20	25																																									
Custom Designs	Custom CV values per case size and termination type may be available upon request. Contact appropriate representative with specific requirements.																																															

U37F Series

U37F Useful Life

Useful Life: 6,500 Hours at +85°C

The life expectancy of a capacitor is shown as a function of ambient temperature and ripple current load.

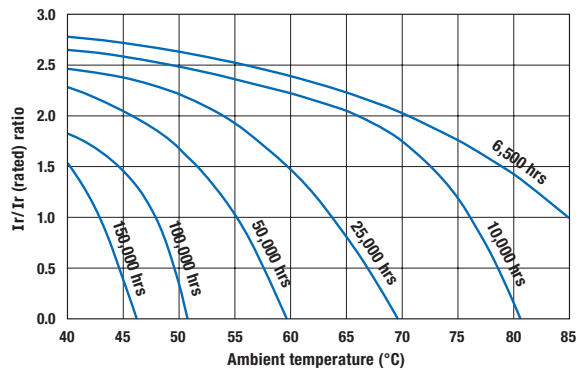
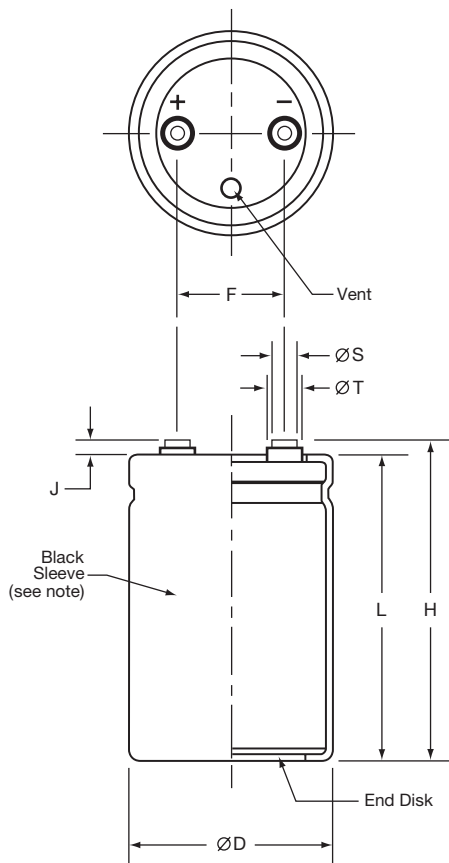

Diagram of Dimensions - Screw Terminals

Large Can/Screw Terminals

Unit: mm (inches)



Case Dimensions and Standard Box Quantities

Case Size Code	ØD +2.0 (0.080)	L ±1.0 (0.040)	F ±0.25 (0.010)	Standard Box Quantity
CB7 CD0	50.8 (2.000)	117 (4.625) 130 (5.125)	22.2 (0.875)	49
D92 DA5 DB7 DD0 DE3	63.5 (2.500)	92 (3.625) 105 (4.125) 117 (4.625) 130 (5.125) 143 (5.625)	28.6 (1.125)	20
E92 EA5 EB7 EE3 EJ1 EM9	76.2 (3.000)	92 (3.625) 105 (4.125) 117 (4.625) 143 (5.625) 181 (7.125) 219 (8.625)	31.8 (1.250)	16 9
F92 FA5 FB7 FE3 FF5 FK0 FM9	89.0 (3.500)	92 (3.625) 105 (4.125) 117 (4.625) 143 (5.625) 155 (6.125) 190 (7.500) 219 (8.625)	31.8 (1.250)	5

Note:

In some cases, the color of the sleeve may change slightly due to the operating conditions, however, the discoloration will not impair capacitor function.

Terminal Specifications

Terminal Code	Available Case Diameter		Thread Size	Minimum Thread Depth	J ±0.5 (0.020)	H ±2.0 (0.080)	ØS ±0.25 (0.010)	ØT ±0.25 (0.010)
	ØD Code	ØD mm (inches)						
HP	C	50.8 (2.000)	10-32 NF-2B	9.5 (0.375)	6.4 (0.250)	L+J	8.0 (0.313)	11.1 (0.438)
HL	C	50.8 (2.000)	M5x0.8-6H	9.5 (0.375)	6.4 (0.250)	L+J	8.0 (0.313)	11.1 (0.438)
CD	D-E	63.5 - 76.2 (2.500 - 3.000)	M5x0.8-6H	8.5 (0.335)	5.0 (0.200)	L+J	13.0 (0.512)	18.8 (0.740)
CP	D-F	63.5 - 89.0 (2.500 - 3.500)	1/4-28 NF-2B	8.7 (0.344)	2.4 (0.093)	L+J	17.5 (0.689)	—
CH	D-F	63.5 - 89.0 (2.500 - 3.500)	1/4-28 NF-2B	11.9 (0.468)	6.4 (0.250)	L+J	17.5 (0.689)	—
CA	D-F	63.5 - 89.0 (2.500 - 3.500)	M6x1-6H	8.7 (0.344)	2.4 (0.093)	L+J	17.5 (0.689)	—
CS	D-F	63.5 - 89.0 (2.500 - 3.500)	M6x1-6H	11.9 (0.468)	6.4 (0.250)	L+J	17.5 (0.689)	—

Mounting Hardware is optional. Refer to hardware specifications on the following page.

U37F Series

Mounting Hardware - Screw Terminals

Type C: Three-Footed Clamp

Unit: mm (inches)

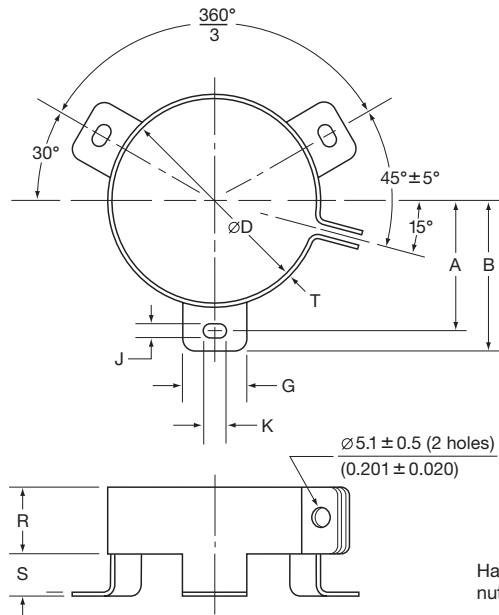

Hardware: Screw, washer and hexagon nut included with each clamp.

Type C: Clamp Dimensions

Mounting Code	Case ØD	A ±1.0 (0.040)	B ±1.0 (0.040)	G ±1.0 (0.040)	J ±0.5 (0.020)	K ±0.5 (0.020)	R ±1.0 (0.040)	S ±1.0 (0.040)	T ±0.5 (0.020)
C	50.8 (2.000)	31.8 (1.250)	36.5 (1.437)	13.3 (0.524)	4.5 (0.177)	7.1 (0.280)	19.1 (0.751)	9.5 (0.374)	0.8 (0.032)
C	63.5 (2.500)	38.1 (1.500)	42.9 (1.689)	13.3 (0.524)	4.5 (0.177)	7.1 (0.280)	19.1 (0.751)	9.5 (0.374)	0.8 (0.032)
C	76.2 (3.000)	44.5 (1.750)	49.2 (1.937)	13.3 (0.524)	4.5 (0.177)	7.1 (0.280)	19.1 (0.751)	9.5 (0.374)	1.0 (0.040)
C	89.0 (3.500)	50.8 (2.000)	56.5 (2.224)	16.0 (0.630)	4.5 (0.177)	8.0 (0.313)	21.0 (0.827)	9.0 (0.354)	1.0 (0.040)

Type S: Stud Mounting

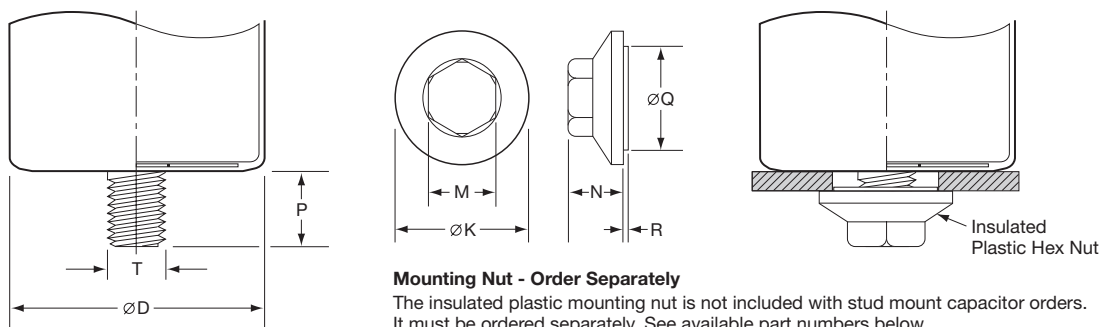

Type S: Stud Dimensions

Mounting Code	P ±1.0 (0.040)	T Thread Size
S	16.0 (0.630)	M12

Mounting Nut Dimensions

Part Number	ØK ±2.0 (0.080)	M ±1.0 (0.040)	N ±1.0 (0.040)	ØQ ±1.0 (0.040)	R ±1.0 (0.040)
50-8D	30.0 (1.181)	19.0 (0.748)	18.0 (0.709)	22.0 (0.866)	1.40 (0.055)
50-8E	38.0 (1.496)	19.0 (0.748)	18.0 (0.709)	30.0 (1.181)	1.40 (0.055)

U37F Series

Part Numbering System for U37F Series When ordering, always specify complete 18-field global part number.

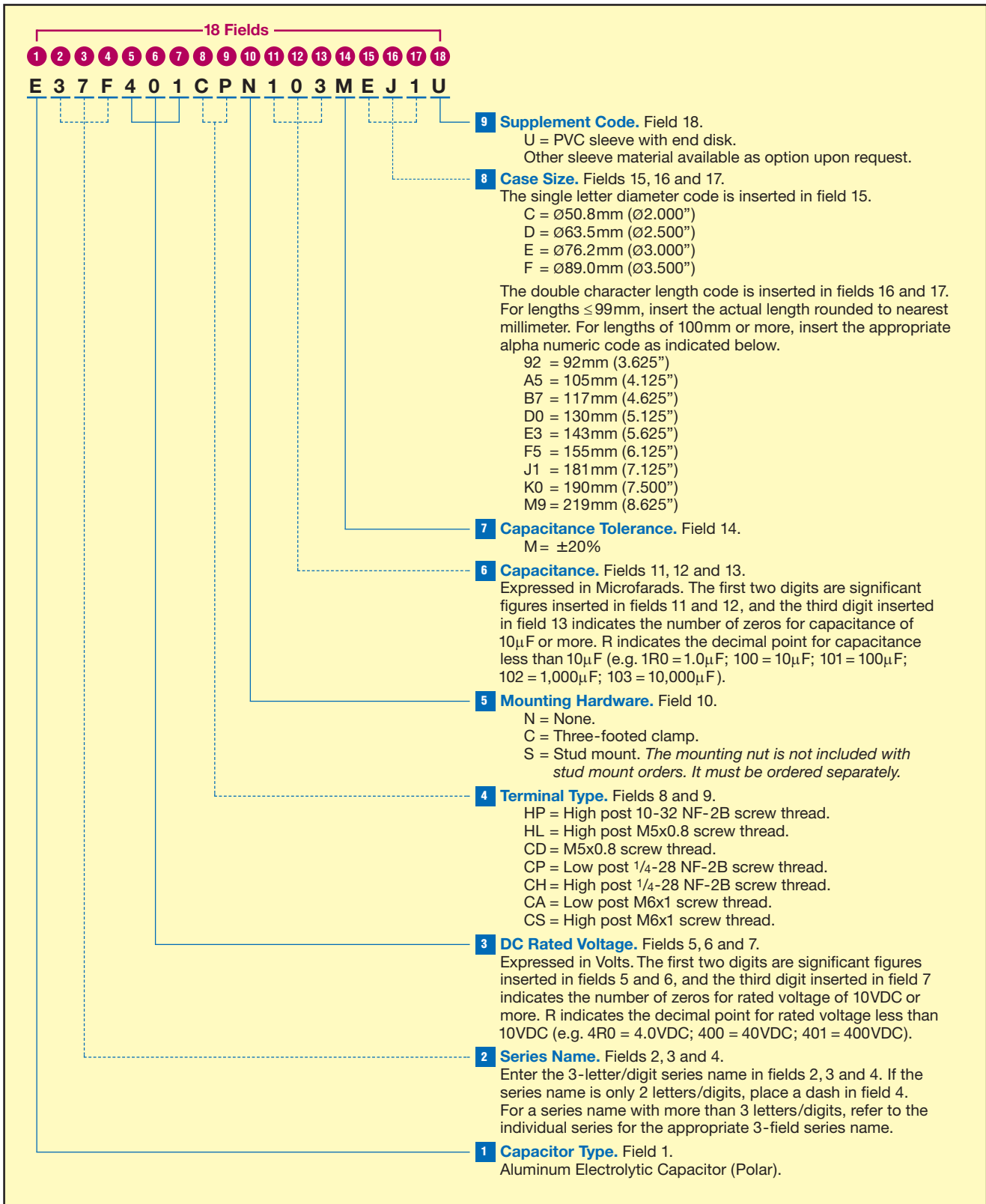



U37F Series

Standard Voltage Ratings - Screw Terminals

Rated Voltage (WVDC)	Capacitance (µF)	Global Part Number†	Nominal Case Size* D x L (mm)	Case Size Code	Maximum ESR (mΩ) at +25°C, 120Hz	Rated Ripple Current (A rms) at +85°C		
						120Hz	300Hz	>3kHz
350 Volts 400 Volts Surge	3,300	E37F351HPN332MCB7U	50 x 117	CB7	28	10.8	12.9	15.1
	3,900	E37F351HPN392MCD0U	50 x 130	CD0	23	12.2	14.6	17.0
	3,300	E37F351CPN332MD92U	63.5 x 92	D92	28	11.2	13.4	15.6
	3,900	E37F351CPN392MDA5U	63.5 x 105	DA5	23	12.7	15.2	17.7
	4,700	E37F351CPN472MDB7U	63.5 x 117	DB7	19	14.5	17.4	20.3
	5,600	E37F351CPN562MDD0U	63.5 x 130	DD0	16	16.4	19.7	22.9
	5,600	E37F351CPN562MDE3U	63.5 x 143	DE3	16	17.0	20.4	23.7
	4,700	E37F351CPN472ME92U	76.2 x 92	E92	20	14.5	17.4	20.2
	5,600	E37F351CPN562MEA5U	76.2 x 105	EA5	17	16.5	19.8	23.1
	6,800	E37F351CPN682MEB7U	76.2 x 117	EB7	14	18.9	22.6	26.4
	8,200	E37F351CPN822MEE3U	76.2 x 143	EE3	12	22.2	26.7	31.1
	12,000	E37F351CPN123MEJ1U	76.2 x 181	EJ1	8	29.4	35.2	41.1
	15,000	E37F351CPN153MEM9U	76.2 x 219	EM9	6	35.4	42.5	49.6
	6,800	E37F351CPN682MF92U	89 x 92	F92	14	19.1	22.9	26.7
	8,200	E37F351CPN822MFA5U	89 x 105	FA5	12	21.8	26.2	30.5
	10,000	E37F351CPN103MFB7U	89 x 117	FB7	10	25.0	30.0	35.0
	12,000	E37F351CPN123MFE3U	89 x 143	FE3	8	29.3	35.2	41.1
	15,000	E37F351CPN153MFF5U	89 x 155	FF5	6	33.8	40.5	47.3
18,000	E37F351CPN183MFK0U	89 x 190	FK0	5	40.0	47.9	55.9	
22,000	E37F351CPN223MFM9U	89 x 219	FM9	4	46.7	56.0	65.4	
400 Volts 450 Volts Surge	2,700	E37F401HPN272MCB7U	50 x 117	CB7	30	10.4	12.5	14.6
	3,300	E37F401HPN332MCD0U	50 x 130	CD0	26	11.6	13.9	16.2
	2,700	E37F401CPN272MD92U	63.5 x 92	D92	30	10.7	12.9	15.0
	3,300	E37F401CPN332MDA5U	63.5 x 105	DA5	25	12.3	14.7	17.2
	3,900	E37F401CPN392MDB7U	63.5 x 117	DB7	21	13.8	16.5	19.3
	4,700	E37F401CPN472MDD0U	63.5 x 130	DD0	19	15.3	18.3	21.4
	4,700	E37F401CPN472MDE3U	63.5 x 143	DE3	17	16.8	20.1	23.5
	3,900	E37F401CPN392ME92U	76.2 x 92	E92	21	14.3	17.2	20.0
	5,600	E37F401CPN562MEA5U	76.2 x 105	EA5	17	16.4	19.6	22.9
	5,600	E37F401CPN562MEB7U	76.2 x 117	EB7	15	18.4	22.0	25.7
	8,200	E37F401CPN822MEE3U	76.2 x 143	EE3	12	22.3	26.8	31.3
	10,000	E37F401CPN103MEJ1U	76.2 x 181	EJ1	9	28.2	33.8	39.5
	12,000	E37F401CPN123MEM9U	76.2 x 219	EM9	7	34.0	40.8	47.6
	5,600	E37F401CPN562MF92U	89 x 92	F92	15	18.6	22.3	26.1
	6,800	E37F401CPN682MFA5U	89 x 105	FA5	12	21.2	25.5	29.7
	8,200	E37F401CPN822MFB7U	89 x 117	FB7	11	23.8	28.6	33.4
	10,000	E37F401CPN103MFE3U	89 x 143	FE3	8	28.9	34.7	40.5
	12,000	E37F401CPN123MFF5U	89 x 155	FF5	7	31.4	37.7	44.0
15,000	E37F401CPN153MFK0U	89 x 190	FK0	6	38.3	45.9	53.6	
18,000	E37F401CPN183MFM9U	89 x 219	FM9	5	43.9	52.7	61.5	
420 Volts 470 Volts Surge	2,700	E37F421HPN272MCB7U	50 x 117	CB7	34	9.8	11.7	13.7
	3,300	E37F421HPN332MCD0U	50 x 130	CD0	28	11.2	13.4	15.7
	2,700	E37F421CPN272MD92U	63.5 x 92	D92	34	10.1	12.1	14.1
	3,300	E37F421CPN332MDA5U	63.5 x 105	DA5	28	11.7	14.0	16.3
	3,900	E37F421CPN392MDB7U	63.5 x 117	DB7	23	13.2	15.8	18.5
	3,900	E37F421CPN392MDD0U	63.5 x 130	DD0	23	13.7	16.4	19.1
	4,700	E37F421CPN472MDE3U	63.5 x 143	DE3	19	15.5	18.6	21.8
	3,900	E37F421CPN392ME92U	76.2 x 92	E92	24	13.2	15.8	18.4
	4,700	E37F421CPN472MEA5U	76.2 x 105	EA5	20	15.1	18.1	21.1
	5,600	E37F421CPN562MEB7U	76.2 x 117	EB7	17	17.1	20.5	24.0
	6,800	E37F421CPN682MEE3U	76.2 x 143	EE3	14	20.2	24.3	28.3
	10,000	E37F421CPN103MEJ1U	76.2 x 181	EJ1	10	26.8	32.2	37.5
	12,000	E37F421CPN123MEM9U	76.2 x 219	EM9	8	31.7	38.0	44.4
	5,600	E37F421CPN562MF92U	89 x 92	F92	17	17.3	20.8	24.2
	6,800	E37F421CPN682MFA5U	89 x 105	FA5	14	19.9	23.8	27.8

† For terminal, mounting and construction options, refer to the part numbering system for descriptions and codes.

* Refer to diagram of dimensions for detailed case size specifications.

**U37F** Series

Standard Voltage Ratings - Screw Terminals

Rated Voltage (WVDC)	Capacitance (μF)	Global Part Number†	Nominal Case Size* D × L (mm)	Case Size Code	Maximum ESR (mΩ) at +25°C, 120Hz	Rated Ripple Current (A rms) at +85°C		
						120Hz	300Hz	>3kHz
420 Volts 470 Volts Surge	8,200	E37F421CPN822MFB7U	89 × 117	FB7	12	22.7	27.2	31.7
	10,000	E37F421CPN103MFE3U	89 × 143	FE3	10	26.8	32.1	37.5
	12,000	E37F421CPN123MFF5U	89 × 155	FF5	8	30.3	36.3	42.4
	15,000	E37F421CPN153MFK0U	89 × 190	FK0	6	36.5	43.8	51.1
	18,000	E37F421CPN183MFM9U	89 × 219	FM9	5	42.2	50.7	59.1
450 Volts 500 Volts Surge	2,700	E37F451HPN272MCB7U	50 × 117	CB7	34	9.8	11.7	13.7
	2,700	E37F451HPN272MCD0U	50 × 130	CD0	34	10.1	12.1	14.2
	2,200	E37F451CPN222MD92U	63.5 × 92	D92	42	9.1	10.9	12.8
	2,700	E37F451CPN272MDA5U	63.5 × 105	DA5	34	10.5	12.7	14.8
	3,300	E37F451CPN332MDB7U	63.5 × 117	DB7	28	12.1	14.6	17.0
	3,900	E37F451CPN392MDD0U	63.5 × 130	DD0	23	13.7	16.4	19.1
	4,700	E37F451CPN472MDE3U	63.5 × 143	DE3	19	15.5	18.6	21.8
	3,900	E37F451CPN392ME92U	76.2 × 92	E92	24	13.2	15.8	18.4
	4,700	E37F451CPN472MEA5U	76.2 × 105	EA5	20	15.1	18.1	21.1
	5,600	E37F451CPN562MEB7U	76.2 × 117	EB7	17	17.1	20.5	24.0
	6,800	E37F451CPN682MEE3U	76.2 × 143	EE3	14	20.2	24.3	28.3
	8,200	E37F451CPN822MEJ1U	76.2 × 181	EJ1	12	24.3	29.1	34.0
	12,000	E37F451CPN123MEM9U	76.2 × 219	EM9	8	31.7	38.0	44.4
	5,600	E37F451CPN562MF92U	89 × 92	F92	17	17.3	20.8	24.2
	6,800	E37F451CPN682MFA5U	89 × 105	FA5	14	19.9	23.8	27.8
	6,800	E37F451CPN682MFB7U	89 × 117	FB7	14	20.6	24.8	28.9
	8,200	E37F451CPN822MFE3U	89 × 143	FE3	12	24.3	29.1	34.0
	12,000	E37F451CPN123MFF5U	89 × 155	FF5	8	30.2	36.3	42.3
15,000	E37F451CPN153MFK0U	89 × 190	FK0	6	36.5	43.8	51.1	
15,000	E37F451CPN153MFM9U	89 × 219	FM9	6	38.6	46.3	54.0	
500 Volts 550 Volts Surge	1,500	E37F501HPN152MCB7U	50 × 117	CB7	63	7.2	8.6	10.1
	1,800	E37F501HPN182MCD0U	50 × 130	CD0	55	8.0	9.6	11.2
	1,800	E37F501CPN182MD92U	63.5 × 92	D92	52	8.2	9.8	11.5
	2,200	E37F501CPN222MDA5U	63.5 × 105	DA5	43	9.4	11.2	13.1
	2,700	E37F501CPN272MDB7U	63.5 × 117	DB7	37	10.5	12.6	14.7
	3,300	E37F501CPN332MDD0U	63.5 × 130	DD0	32	11.7	14.0	16.3
	3,300	E37F501CPN332MDE3U	63.5 × 143	DE3	29	12.8	15.4	17.9
	2,700	E37F501CPN272ME92U	76.2 × 92	E92	36	10.9	13.1	15.3
	3,300	E37F501CPN332MEA5U	76.2 × 105	EA5	30	12.5	15.0	17.5
	3,900	E37F501CPN392MEB7U	76.2 × 117	EB7	25	14.0	16.8	19.6
	5,600	E37F501CPN562MEE3U	76.2 × 143	EE3	20	17.1	20.5	23.9
	6,800	E37F501CPN682MEJ1U	76.2 × 181	EJ1	15	21.5	25.8	30.1
	8,200	E37F501CPN822MEM9U	76.2 × 219	EM9	12	26.0	31.2	36.3
	3,900	E37F501CPN392MF92U	89 × 92	F92	25	14.2	17.1	19.9
	4,700	E37F501CPN472MFA5U	89 × 105	FA5	21	16.2	19.5	22.7
	5,600	E37F501CPN562MFB7U	89 × 117	FB7	18	18.2	21.8	25.5
	6,800	E37F501CPN682MFE3U	89 × 143	FE3	14	22.1	26.5	30.9
	8,200	E37F501CPN822MFF5U	89 × 155	FF5	13	24.0	28.8	33.6
10,000	E37F501CPN103MFK0U	89 × 190	FK0	10	29.2	35.1	40.9	
12,000	E37F501CPN123MFM9U	89 × 219	FM9	8	33.5	40.2	46.9	

†For terminal, mounting and construction options, refer to the part numbering system for descriptions and codes.

*Refer to diagram of dimensions for detailed case size specifications.



- Always read "Notes on Use" before using the product in order to enable you to use the product correctly and prevent any faults and accidents from occurring.
- Request the Product Specification on the product of NIPPON CHEMI-CON CORPORATION to refer to it as well as this brochure prior to the order of the products. Some specific notes on use of the ordered product may be described in the specifications.
- The products listed in this catalog are designed and manufactured for general electronics equipment use and are not intended for use in applications that can adversely affect human life; where the malfunction of equipment may cause damage to life or property. In addition, our products are not intended to be used in specific applications that may cause a major social impact. Please consult with us in advance of usage of our products in the following listed applications. ① Aerospace equipment ② Power generation equipment such as thermal power, nuclear power etc. ③ Medical equipment ④ Transport equipment (automobiles, trains, ships, etc.) ⑤ Transportation control equipment ⑥ Disaster prevention / crime prevention equipment ⑦ Highly publicized information processing equipment ⑧ Submarine equipment ⑨ Other applications that are not considered general-purpose applications.
- The circuits described as examples in this catalog and the "delivery specifications" are featured in order to show the operations and usage of our products, however, this fact does not guarantee that the circuits are available to function in your equipment systems. We are not in any case responsible for any failures or damage caused by the use of information contained herein. You should examine our products, of which the characteristics are described in the "delivery specifications" and other documents, and determine whether or not our products suit your requirements according to the specifications of your equipment systems. Therefore, you bear final responsibility regarding the use of our products.
Please make sure that you take appropriate safety measures such as use of redundant design and malfunction prevention measures in order to prevent fatal accidents and/or fires in the event any of our products malfunction.
- We strongly recommend our customers to purchase Nippon Chemi-Con products only through our official sales channels. We assume no responsibility for any defects or damages caused by using products purchased from outside our official sales channel or of counterfeit goods. In addition, we will ask the customer to pay the investigation cost for products purchased outside our official sales channel.
- We reserve the right to discontinue production and delivery of products. We do not guarantee that all the products included in this catalog will be available in the future.
The aforementioned does not apply in the case of individual agreements deviating from the foregoing for customer-specific products
- We continually strive to improve the quality and reliability of our products, but in any case that our product does not meet our published specifications, please stop using it promptly and contact us immediately. As for compensation for non-conforming goods delivered by Chemi-Con, we will limit it only to goods found in non-compliance of our published specifications. This may be accomplished by a no cost replacement of non-conforming individual products, a credit of the piece price paid per each individual non-conforming product, or in other ways deemed necessary.
In addition, we have an established system with enhanced traceability, therefore we will limit the applicable lot items for any potential compensation.

[Part Numbering System](#)

[Part Numbering System \(Appendix\)](#)

[Standardization](#)

[Available Items by Manufacturing Locations](#)

[Environmental Measures](#)

[Technical Note](#)

[Precautions and Guidelines](#)

[Recommended Soldering Conditions](#)

[Taping, Lead-preforming and Packaging](#)

[Available Terminals for Snap-in and Screw Mount Type](#)