

# Model 647H

## Very Low Jitter HCSL Clock

### Features

- High Speed Current Steering Logic [HCSL] Output
- Ceramic Surface Mount Package
- Low Phase Jitter Performance, 500fs Typical
- Fundamental or 3<sup>rd</sup> Overtone Crystal Design
- Frequency Range 13.5MHz – 200MHz \*
- +2.5V or +3.3V Operation
- Output Enable Standard
- Tape and Reel Packaging, EIA-481

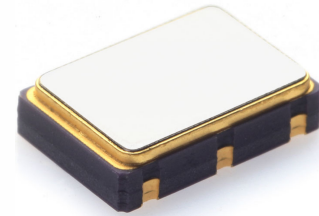

Part Dimensions:  
7.0 × 5.0 × 1.65mm • 174.2mg

### Applications

- PCI Express [PCIe]
- Data Storage Systems
- Ethernet Line Cards
- Serial ATA Express [SATAe]
- Intel Chipsets
- Network Servers
- Switches and Routers
- Set-Top Boxes/DVRs

### Standard Frequencies

\* See Page 8 for common frequencies.  
Check with factory for availability of frequencies not listed.

### Description

CTS Model 647H is a low cost, high performance clock oscillator supporting HCSL output. Employing the latest IC technology, M647H has excellent stability and low phase jitter performance.

### Ordering Information

Model	Output Type	Frequency Code [MHz]	Frequency Stability	Temperature Range	Supply Voltage	Packaging																									
647	H	XXX or XXXX	3	I	3	T																									
<table border="1"> <thead> <tr> <th>Code</th> <th>Output</th> </tr> </thead> <tbody> <tr> <td>H</td> <td>HCSL - Pin 1 Enable</td> </tr> </tbody> </table>		Code	Output	H	HCSL - Pin 1 Enable	<table border="1"> <thead> <tr> <th>Code</th> <th>Stability</th> </tr> </thead> <tbody> <tr> <td>5</td> <td>±25ppm</td> </tr> <tr> <td>4</td> <td>±30ppm</td> </tr> <tr> <td>3</td> <td>±50ppm</td> </tr> <tr> <td>2</td> <td>±100ppm</td> </tr> </tbody> </table>		Code	Stability	5	±25ppm	4	±30ppm	3	±50ppm	2	±100ppm	<table border="1"> <thead> <tr> <th>Code</th> <th>Voltage</th> </tr> </thead> <tbody> <tr> <td>2</td> <td>+2.5Vdc</td> </tr> <tr> <td>3</td> <td>+3.3Vdc</td> </tr> </tbody> </table>		Code	Voltage	2	+2.5Vdc	3	+3.3Vdc	<table border="1"> <thead> <tr> <th>Code</th> <th>Packing</th> </tr> </thead> <tbody> <tr> <td>T</td> <td>1k pcs./reel</td> </tr> </tbody> </table>		Code	Packing	T	1k pcs./reel
Code	Output																														
H	HCSL - Pin 1 Enable																														
Code	Stability																														
5	±25ppm																														
4	±30ppm																														
3	±50ppm																														
2	±100ppm																														
Code	Voltage																														
2	+2.5Vdc																														
3	+3.3Vdc																														
Code	Packing																														
T	1k pcs./reel																														
		<table border="1"> <thead> <tr> <th>Code</th> <th>Frequency</th> </tr> </thead> <tbody> <tr> <td colspan="2">Product Frequency Code<sup>1</sup></td> </tr> </tbody> </table>		Code	Frequency	Product Frequency Code <sup>1</sup>		<table border="1"> <thead> <tr> <th>Code</th> <th>Temp. Range</th> </tr> </thead> <tbody> <tr> <td>C</td> <td>-20°C to +70°C</td> </tr> <tr> <td>I</td> <td>-40°C to +85°C</td> </tr> <tr> <td>G</td> <td>-40°C to +105°C<sup>2</sup></td> </tr> </tbody> </table>		Code	Temp. Range	C	-20°C to +70°C	I	-40°C to +85°C	G	-40°C to +105°C <sup>2</sup>														
Code	Frequency																														
Product Frequency Code <sup>1</sup>																															
Code	Temp. Range																														
C	-20°C to +70°C																														
I	-40°C to +85°C																														
G	-40°C to +105°C <sup>2</sup>																														

#### Notes:

- 1) Refer to document 016-1454-0, Frequency Code Tables. 3-digits for frequencies <100MHz, 4-digits for frequencies 100MHz or greater.
- 2) Check factory for availability. Stability codes 2 and 3 only.

**Not all performance combinations and frequencies may be available.  
Contact your local CTS Representative or CTS Customer Service for availability.**

This product is specified for use only in standard commercial applications. Supplier disclaims all express and implied warranties and liability in connection with any use of this product in any non-commercial applications or in any application that may expose the product to conditions that are outside of the tolerances provided in its specification.



## Electrical Specifications

### Operating Conditions

PARAMETER	SYMBOL	CONDITIONS	MIN	TYP	MAX	UNIT
Maximum Supply Voltage	V <sub>CC</sub>	-	-0.3	-	4.0	V
Supply Voltage	V <sub>CC</sub>	±5%	2.375 3.135	2.5 3.3	2.625 3.465	V
Supply Current	I <sub>CC</sub>	Maximum Load Maximum Current Value @ +3.3V	-	-	60	mA
Operating Temperature	T <sub>A</sub>	-	-20 -40	+25	+70 +85	°C
Storage Temperature	T <sub>STG</sub>	-	-50	-	+125	°C

### Frequency Stability

PARAMETER	SYMBOL	CONDITIONS	MIN	TYP	MAX	UNIT
Frequency Range	f <sub>0</sub>	-		13.5 - 200		MHz
Frequency Stability [Note 1]	Δf/f <sub>0</sub>	-		25, 30, 50 or 100		±ppm
Aging	Δf/f <sub>25</sub>	First Year @ +25°C, nominal V <sub>CC</sub>	-5	±3	5	ppm

1.] Inclusive of initial tolerance at time of shipment, changes in supply voltage, load, temperature and 1st year aging.

### Output Parameters

PARAMETER	SYMBOL	CONDITIONS	MIN	TYP	MAX	UNIT
Output Type	-	-		HCSL		-
Output Load	R <sub>L</sub>	Terminated to ground	-	50	-	Ohms
Output Voltage Levels	V <sub>OH</sub> V <sub>OL</sub>	HCSL Load	580 -150	-	850 150	mV
Output Duty Cycle	SYM	Differential Output, @ V <sub>CC</sub> - 1.3V	45	-	55	%
Differential Output Voltage	V <sub>OD</sub>	R <sub>L</sub> = 50 Ohms to ground	0.4	-	-	Vp-p
Rise and Fall Time	T <sub>R</sub> , T <sub>F</sub>	@ 20%/80% Levels, R <sub>L</sub> = 50 Ohms to ground	-	0.50	0.70	ns

### Output Parameters

PARAMETER	SYMBOL	CONDITIONS	MIN	TYP	MAX	UNIT
Start Up Time	T <sub>S</sub>	Application of V <sub>CC</sub>	-	5	10	ms
Enable Function [Standby]						
Enable Input Voltage	V <sub>IH</sub>	Pin 1 Logic '1', Output Enabled	0.7V <sub>CC</sub>	-	-	V
Disable Input Voltage	V <sub>IL</sub>	Pin 1 Logic '0', Output Disabled	-	-	0.3V <sub>CC</sub>	V
Disable Current	I <sub>IL</sub>	Pin 1 Logic '0', Output Disabled	-	15	-	μA
Enable Time	T <sub>PLZ</sub>	Pin 1 Logic '1', Output Enabled	-	-	2	ms
Phase Jitter, RMS	tj <sub>rms</sub>	Bandwidth 12 kHz - 20 MHz	-	500	-	fs

## Electrical Specifications

### Enable Truth Table

Pin 1	Pin 4 & Pin 5
Logic '1'	Output Enabled
Open	Output Enabled
Logic '0'	Output Disabled, High Impedance

### Test Circuit

HCSL

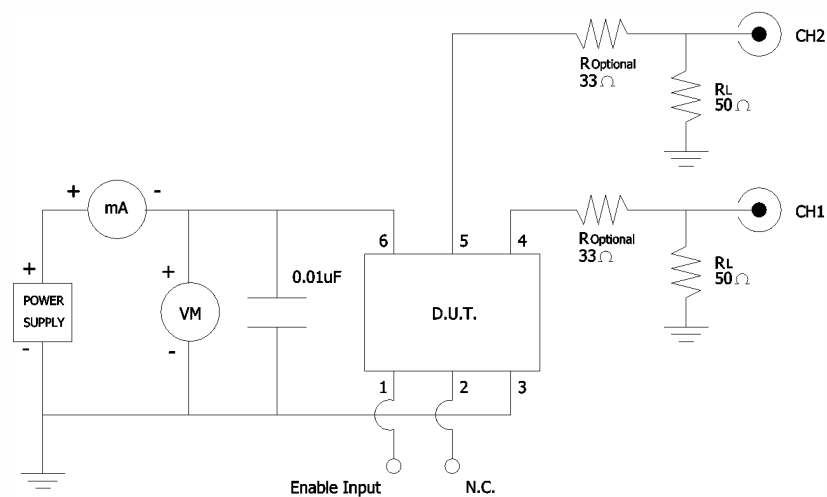

### Output Waveform

HCSL

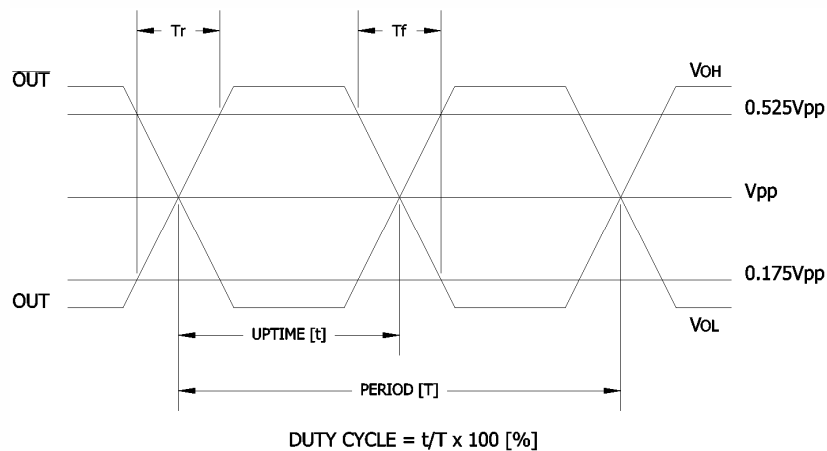

## Electrical Specifications

### Performance Data

Phase Noise [typical]

100.00MHz, HCSL,  $V_{CC} = 3.3V$ ,  $T_A = +25^\circ C$

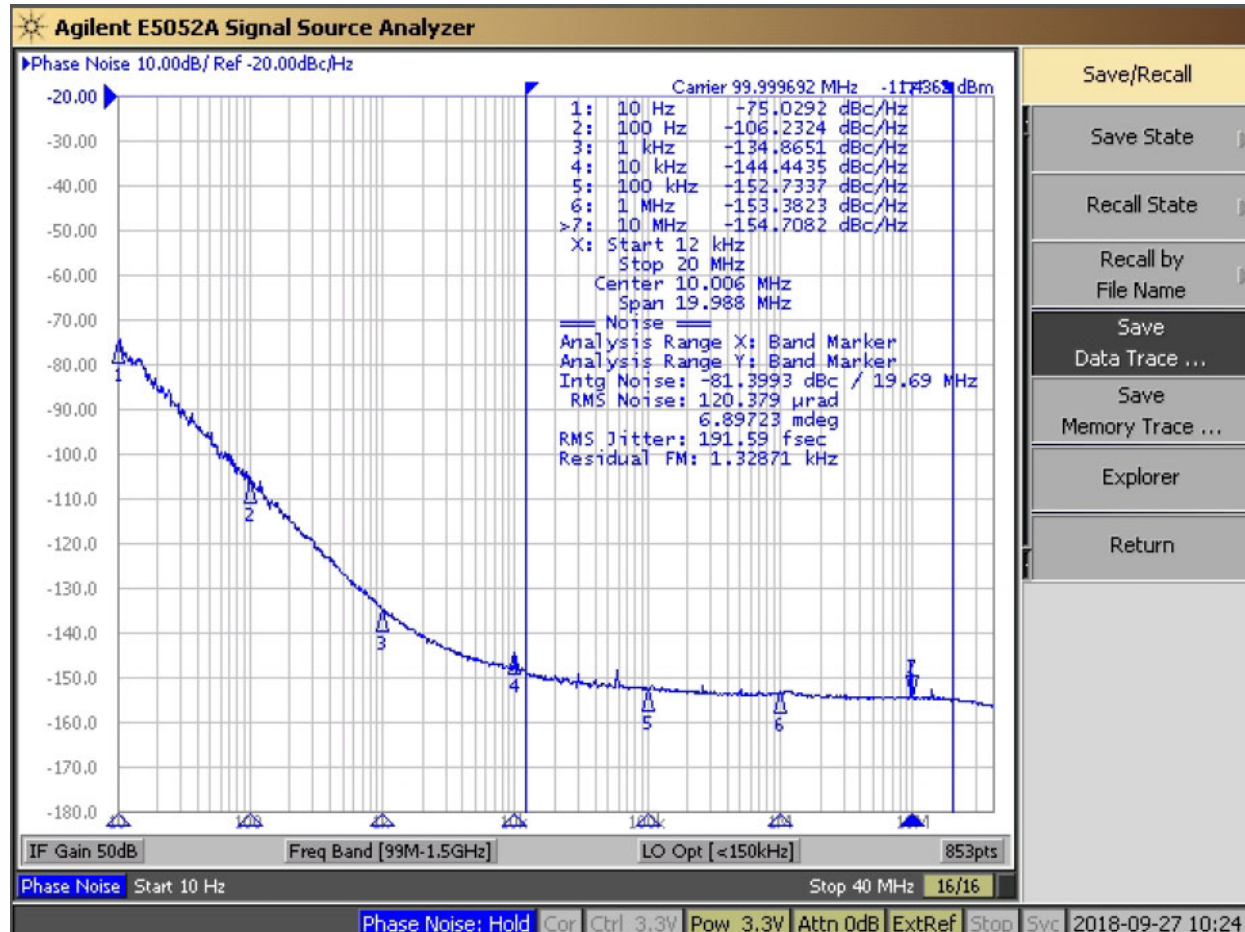



## Electrical Specifications

### Performance Data

#### Phase Noise Tabulated

Typical, 100.00MHz, HCSL,  $V_{CC} = 3.3V$ ,  $T_A = +25^{\circ}C$

PARAMETER	SYMBOL	CONDITIONS	TYP	UNIT
<b>HCSL @ 100.00MHz</b>				
<b>Phase Noise</b>		Single Side Band		
		@ 10Hz	-75.9328	
		@ 100Hz	-106.9929	
		@ 1kHz	-135.1951	dBc/Hz
		@ 10kHz	-144.2209	
		@ 100kHz	-152.8159	
		@ 1MHz	-153.5793	
	@ 10MHz	-154.8219		
<b>Phase Jitter, RMS</b>	tjrms	Integration Bandwidth 12kHz - 20MHz	188.2315	fs

## Mechanical Specifications

### Package Drawing

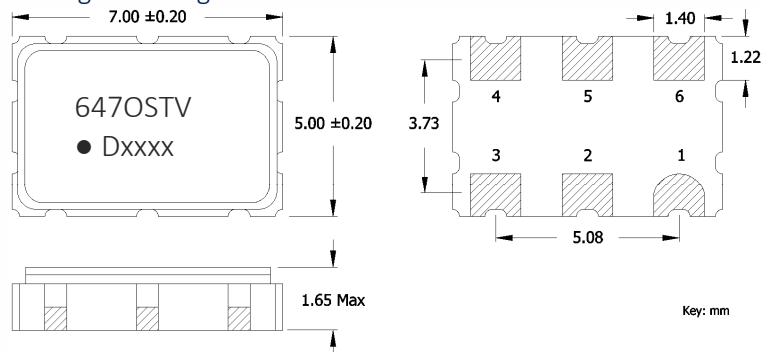

### Marking Information

1. O – Output Type; H = HCSL.
2. ST – Frequency Stability/Temperature Code. [Refer to Ordering Information]
3. V – Voltage Code; 3 = 3.3V, 2 = 2.5V.
4. D – Date Code. See Table I for codes.
5. xxxx – Frequency Code.  
3-digits, frequencies below 100MHz  
4-digits, frequencies 100MHz or greater  
[See document 016-1454-0, Frequency Code Tables.]

### Recommended Pad Layout

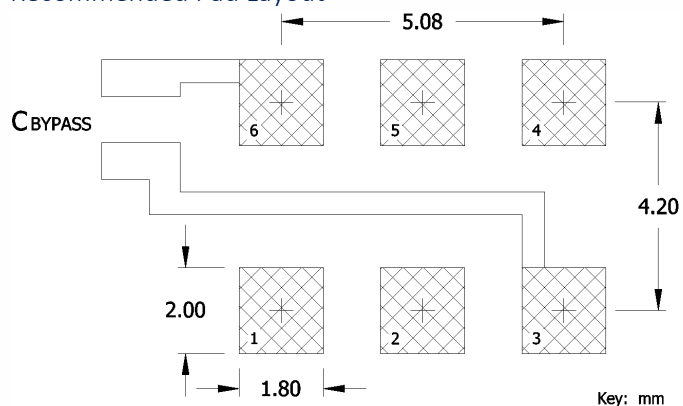

### Notes

1. JEDEC termination code (e4). Barrier-plating is nickel [Ni] with gold [Au] flash plate.
2. Reflow conditions per JEDEC J-STD-020; +260°C maximum, 20 seconds.
3. MSL = 1.

### Pin Assignments

Pin	Symbol	Function
1	EOH	Enable
2	N.C.	No Connect
3	GND	Circuit & Package Ground
4	Output	RF Output
5	$\overline{\text{Output}}$	Complimentary RF Output
6	V <sub>CC</sub>	Supply Voltage

Table I - Date Code, Beginning year 2021

		MONTH														
		JAN	FEB	MAR	APR	MAY	JUN	JUL	AUG	SEP	OCT	NOV	DEC			
YEAR																
2021	2025	2029	2033	2037	A	B	C	D	E	F	G	H	J	K	L	M
2022	2026	2030	2034	2038	N	P	Q	R	S	T	U	V	W	X	Y	Z
2023	2027	2031	2035	2039	a	b	c	d	e	f	g	h	j	k	l	m
2024	2028	2032	2036	2040	n	p	q	r	s	t	u	v	w	x	y	z

## Packaging - Tape and Reel

### Tape Drawing

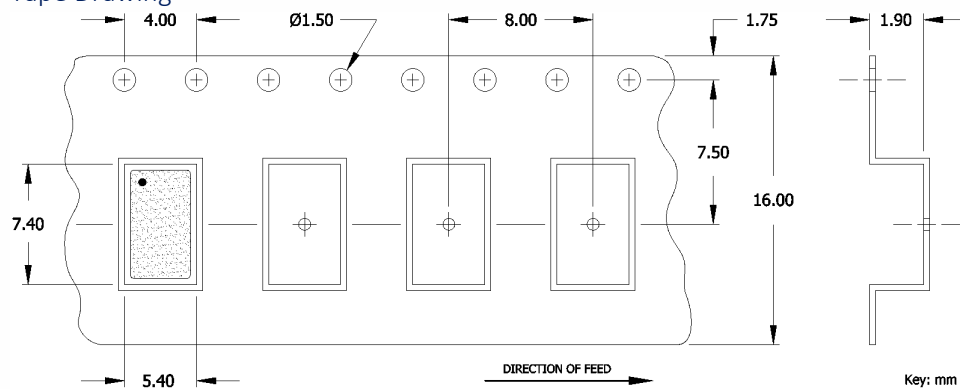

### Reel Drawing

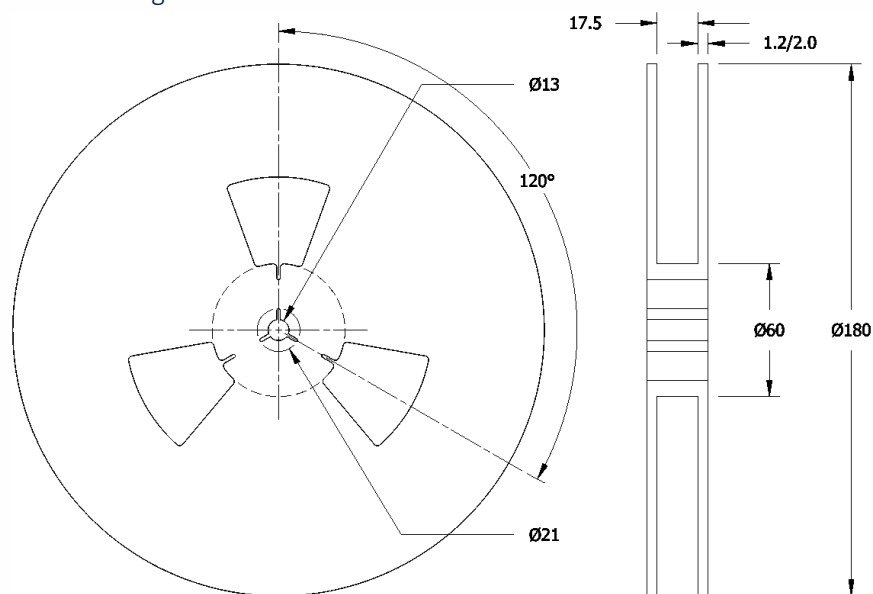

### Notes

1. Device quantity is 1k pieces maximum per 180mm reel.
2. Complete CTS part number, frequency value and date code information must appear on reel and carton labels.



## Addendum

### Common Frequencies Available – MHz

---

FREQUENCY	FREQUENCY CODE	FREQUENCY	FREQUENCY CODE	FREQUENCY	FREQUENCY CODE	FREQUENCY	FREQUENCY CODE
25.000000	250						
27.000000	270						
50.000000	500						
<b>100.000000</b>	<b>1000</b>						
106.250000	1062						
125.000000	1250						
155.520000	1555						
156.250000	1562						

---