

M12 transf. 1000BASE-T x ANG w/o PoE



Image is for illustration purposes only. Please refer to product description.

Part number	21 03 381 4820
Specification	M12 transf. 1000BASE-T x ANG w/o PoE
HARTING eCatalogue	https://harting.com/21033814820

Identification

Category	Connectors
Series	Circular connectors M12
Identification	Magnetics
Element	PCB adapter
Specification	with integrated transformer Angled

Version

Termination method	Reflow soldering termination (SMT)
Gender	Female
Shielding	Shielded
Number of contacts	8
Coding	X-coding
Details	Order housings separately
Pack contents	30 pieces in a tray

Technical characteristics

Rated current	0.8 A
Rated voltage	57 V
Rated impulse voltage	1.5 kV
Pollution degree	3
Data rate	1 Gbit/s
Insulation resistance	$>10^8 \Omega$



Pushing Performance
Since 1945

Technical characteristics

Contact resistance	≤10 mΩ
Limiting temperature	-40 ... +85 °C (during reflow soldering max. +245)
Insertion force	30 N
Withdrawal force	30 N
Mating cycles	≥100
Degree of protection acc. to IEC 60529	IP65 / IP67 mated condition
Isolation group	IIIa (175 ≤ CTI < 400)
Process Sensitivity Level (PSL)	R7 acc. to ECA/IPC/JEDEC J-STD-075

Material properties

Material (insert)	Liquid crystal polymer (LCP)
Colour (insert)	Black
Material (contacts)	Brass
Surface (contacts)	Au over Ni Mating side
Material flammability class acc. to UL 94	V-0
RoHS	compliant with exemption
RoHS exemptions	6(c): Copper alloy containing up to 4 % lead by weight
ELV status	compliant with exemption
China RoHS	50
REACH Annex XVII substances	Not contained
REACH ANNEX XIV substances	Not contained
REACH SVHC substances	Yes
REACH SVHC substances	Lead
ECHA SCIP number	0d7d3693-d625-47ab-934a-d241bf72c86e
California Proposition 65 substances	Yes
California Proposition 65 substances	Lead Nickel
Fire protection on railway vehicles	EN 45545-2 (2020-08) + A1 (2023-10)
Requirement set with Hazard Levels	R26

Specifications and approvals

Specifications	IEC 61076-2-109
----------------	-----------------

Commercial data

Packaging size	30
Net weight	15 g
Country of origin	China
European customs tariff number	85366990
GTIN	5713140228948
eCl@ss	27460201 PCB connector (board connector)
ETIM	EC002637
UNSPSC 24.0	39121415

Panel cut out

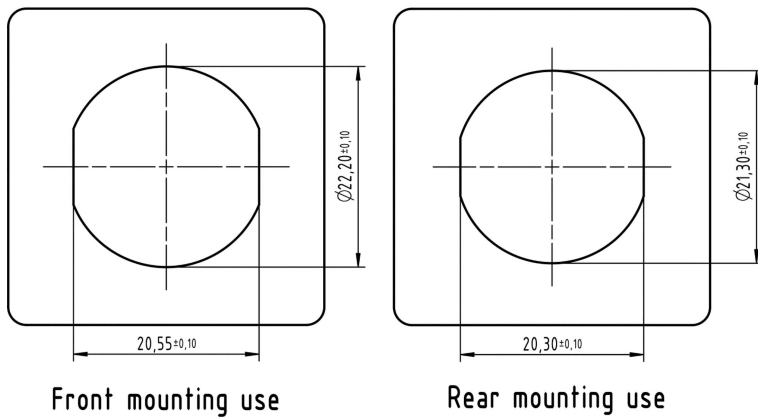

General information

Schematic

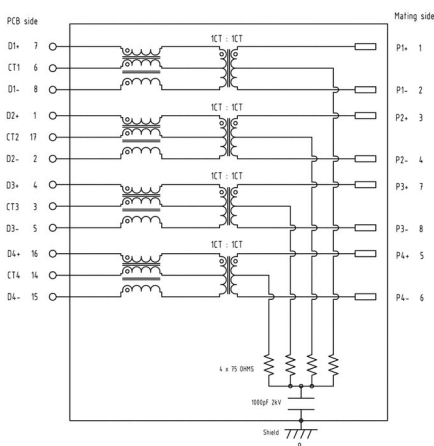

Recommended PCB layout

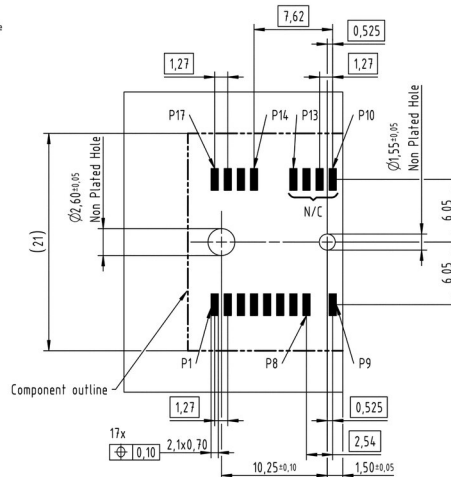

Electrical Characteristics @+25°C unless otherwise noted
 Meets IEEE802.3 specification
 RoHS compliant

Parameter	Specification/ Limit Values
Operating Temperature	-40°C - +85°C
Turn Ratio (+/- 2%)	1CT : 1CT
OCL	min 350µH @ 100KHz , 100mV with 8mA bias current
Isolation (Input- Output)	2.25kV VDC , for 60sec. min f ≤ 100MHz
Insertion Loss	1.3 db
Return Loss	9 db
Crosstalk	30 db
CMRR	30 db
CDMR	30 db

NOTE: 1. f is the frequency in MHz
 2. The Product has been tested for DC isolation. HARTING assumes no liability or obligation for AC isolation testing.

Tape layout & packaging

