

# Unit Step16

SKU:U198

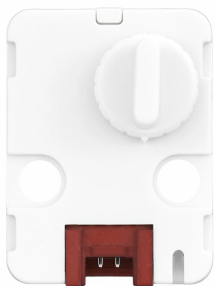

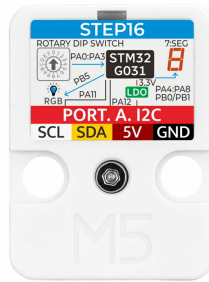
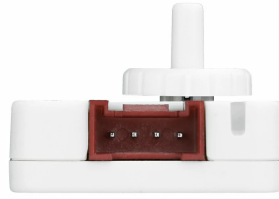

## Description

**Unit Step16** is a 16-position rotary encoder control unit based on an STM32G031G8U6 microcontroller. It collects the BCD value of the rotary encoder in real time and visualizes the 0–F hexadecimal value via the on-board 7-segment display. The device communicates over I2C and allows you to configure the rotation increment direction, display operating mode, RGB LED color, and I2C address, enabling multiple encoder units to be used on the same bus. With its concise and efficient design, Unit Step16 provides reliable physical interaction and instant visual feedback, making it ideal for smart interactive devices (e.g. smart-home control panels), control interfaces (e.g. volume knobs, RGB lighting control, motor speed regulation), and STEAM education hardware prototyping and teaching.

## Features

- 16-position BCD rotary encoder
- Integrated 7-segment display for code visualization
- Adjustable display brightness and operating mode
- Clockwise / counter-clockwise direction setting
- Configurable RGB LED color / brightness
- I2C communication with configurable address
- Development Platform
  - UiFlow1
  - UiFlow2
  - Arduino IDE

## Includes

- 1 x Unit Step16
- 1 x HY2.0-4P Grove Cable (20cm)

## Applications

- Smart interactive devices (e.g. smart-home control panels)
- Device control interfaces (e.g. volume adjustment, RGB LED lighting control, motor speed regulation)
- STEAM education

# Specifications

Specification	Parameter
MCU	STM32G031G8U6, 32-bit ARM Cortex-M0+ core, 64 MHz main frequency
Step Encoding	16 positions, 8421 BCD encoding
Encoding Display	7-segment display
Programmable RGB	1 x WS2812
Encoding Update Cycle	100ms
Communication Port	I2C @0x48, address range: 0x08 ~ 0x77, retains data when powered off
Standby Power Consumption	DC 5V@5.85mA
Operating Power Consumption	LED display at 60%: DC 5V@14.76mA LED display at 100%: DC 5V@24.13mA RGB light at 100%: DC 5V@18.9mA LED/RGB fully on: DC 5V@29.91mA
Product Size	32.0 x 24.0 x 16.9mm
Product Weight	5.5g
Package Size	138.0 x 93.0 x 13.0mm
Gross Weight	10.9g

## Learn

### Rotary Encoder Usage

To prolong the service life of the encoder, please rotate it with moderate force and avoid violent repeated rotations.

## Schematics

- [Unit Step16 Schematics PDF](#)

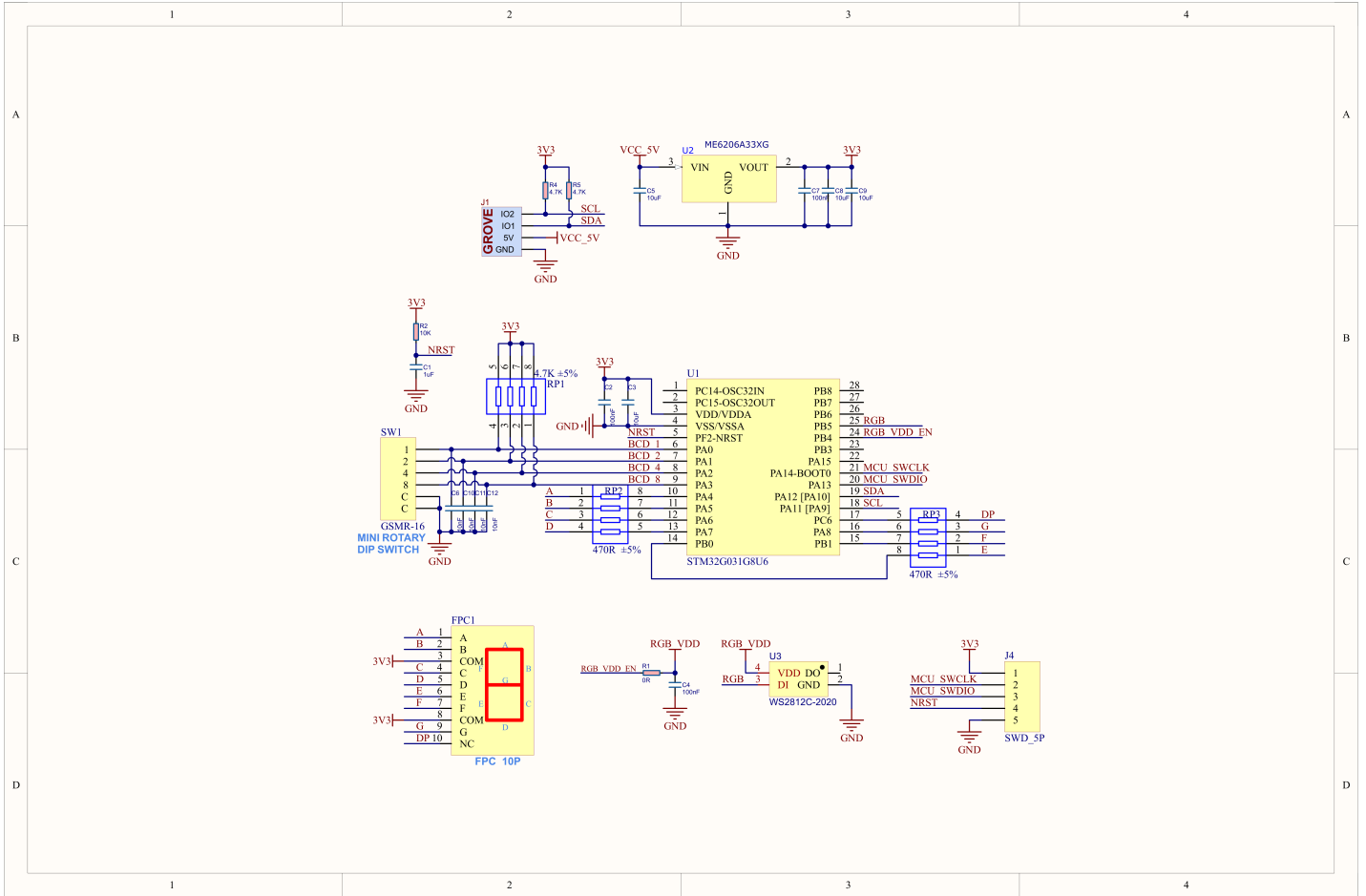

## PinMap

### HY2.0-4P

HY2.0-4P	Black	Red	Yellow	White
PORT.A	GND	5V	SDA	SCL

## Datasheets

- [GSMR-16 Datasheet](#)

## Model Size

- [Unit Step16 Model Size PDF](#)

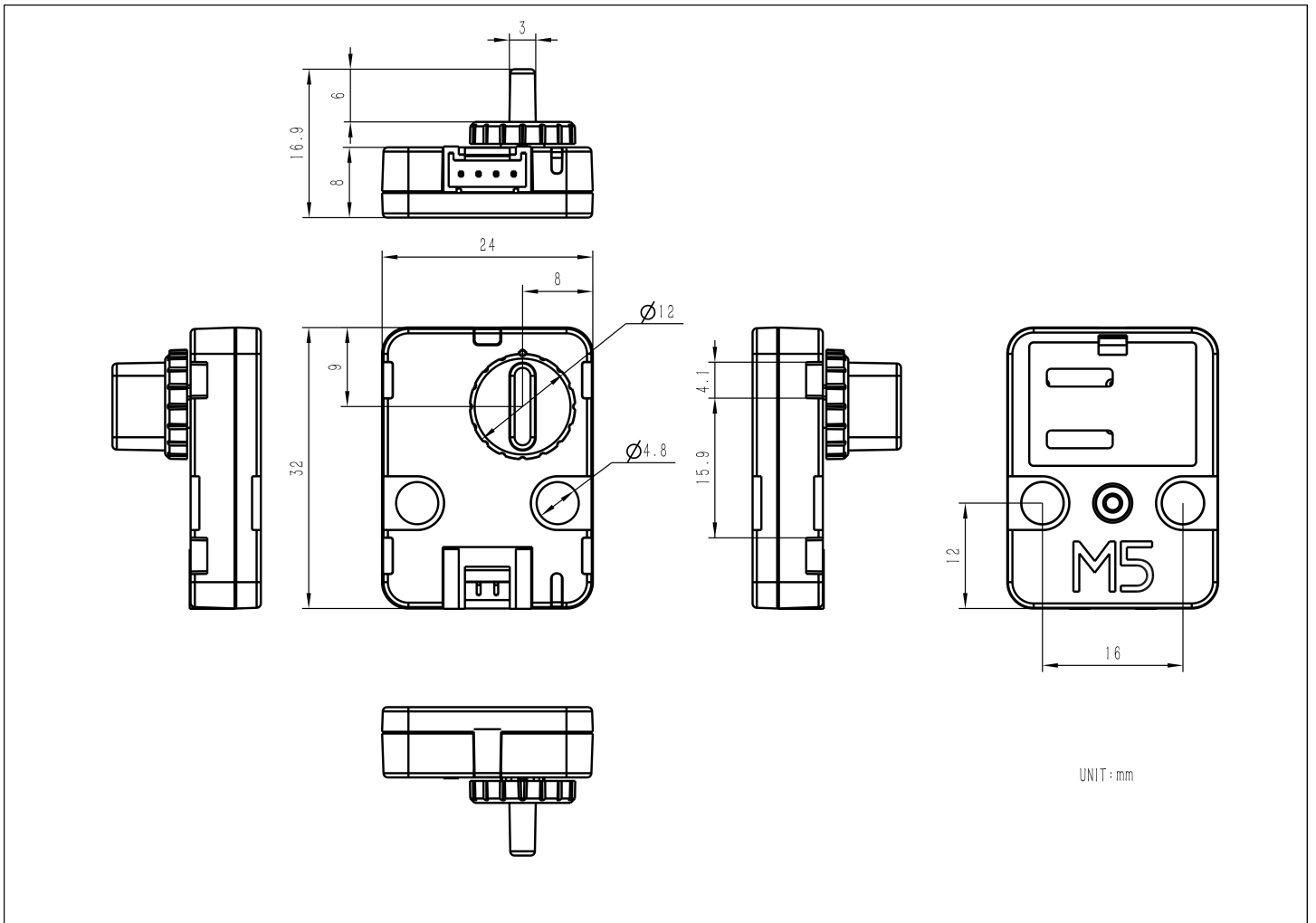

## Softwares

### Arduino

- [Unit Step16 Arduino Quick Start](#)
- [Unit Step16 Arduino Library](#)

### UiFlow2

- [Unit Step16 UiFlow2 Docs](#)

### Home Assistant

- [Home Assistant Integration](#)

### Internal Firmware

- [Unit Step16 Internal Firmware](#)

### Protocol

- [Unit Step16 I2C Protocol](#)

M5Stack Unit Step16 I2C Protocol											V1 (FW Version)						
REG MAP (Addr: 0x48)											2025/7/4						
											note						
REG MAP (Addr: 0x48)	0	1	2	3	4	5	6	7	8	9	A	B	C	D	E	F	
Step16 Value	0x00 R	Value															Value: 0x00-0x0F
Step16 LED Configuration	0x10 R/W	Config															Config: 0-0xFE 0x00: Always Off 0xFE: Always On 0-0xFD: If the device's position, status, and brightness remain unchanged within the specified time, it will enter sleep mode and automatically wake up upon the next state change. Unit: seconds. default: 0xFE
Step16 LED Brightness	0x20 R/W	Brightness															Brightness: 0-100 default: 50
Step16 Switch	0x30 R/W	Value															Value: 0-1 0: Counterclockwise increase 1: Clockwise increase default: 1
Step16 RGB Configuration	0x40 R/W	Power	Brightness														Power: 0-1 0: OFF 1: ON default: 1 Brightness: 0-100 default: 50
Step16 RGB Color	0x50 R/W	RGB_R	RGB_G	RGB_B													RGB_R/G/B: RGB Value value: 0-255 default: 0
Save configuration to flash	0xF0 W	Write value															Write 1 to save the configuration of LED, and write 2 to save the configuration of RGB.
Firmware Version	0xF0 R														Version		Version: Software Version
I2C Address	0xF0 R/W														Address		Address: I2C Address value: 0x08-0x77 default: 0x48
<b>Register Description:</b> <b>1. Step16 LED Configuration</b> Controls the operating status of the indicator light, allowing it to be set to always on, always off, or turn off after a specified time. <b>2. Step16 LED Brightness</b> Controls the brightness of the LED. <b>3. Step16 Switch</b> Switches the rotation direction. The default is clockwise to increase, and counterclockwise to decrease. <b>4. Step16 RGB Configuration</b> Enables RGB and sets its brightness. Note that after enabling RGB, wait approximately 50ms for voltage stabilization before refreshing it. <b>5. Save Configuration to Flash</b> Write 1 to this register to save the current configuration to the internal Flash. Configuration content includes: Step16 LED Configuration Step16 LED Brightness Step16 Switch Write 2 to this register to save the current configuration to the internal Flash. The configuration includes: Step16 RGB power Step16 RGB brightness <b>7. I2C Address</b> After successful configuration, the I2C address will be stored in internal Flash memory, will not be lost during power-down, and will take effect immediately. <b>Notes:</b> 1. Writing to Flash requires first erasing the internal Flash, which takes some time, approximately 20ms. 2. To extend the lifespan of the Flash, avoid frequent write operations. 3. If the value to be written is the same as the current value stored in Flash, the write operation will be skipped to avoid unnecessary erase cycles, further extending the Flash's lifespan.																	

## Video

Unit Step16 product introduction and demo

[U198-Unit\\_Step16\\_video.mp4](#)