

Unit Roller485

SKU:U182

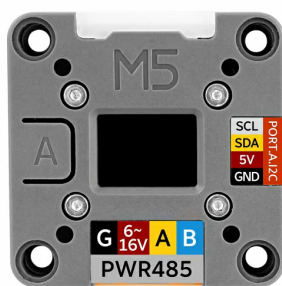



Description

Unit Roller485 is a brushless DC motor motion execution kit with integrated control functions, designed for efficient motion control. The product supports 6-16V DC power input (via the PWR485 interface) or 5V input (via the Grove interface), and can automatically adjust the power coefficient to ensure optimal performance.

It features a built-in **FOC** closed-loop drive system, using a 3504 200KV brushless motor, with a maximum continuous phase current of 0.5A and a short-term peak of 1A without forced cooling. The driver uses a magnetic encoder as feedback, supporting current, speed, and position triple-loop control to ensure precise control. The device offers an optional electrical slip ring, allowing the top Grove interface to remain connected to the bottom even during 360° rotation, enabling additional modules to be expanded on the top while ensuring power and data transmission for the rotating part.

Additionally, the device is equipped with a 0.66-inch **OLED** display on the back to show real-time status. It also includes built-in RGB indicators and function buttons for easy human-machine interaction. The product's top and base designs feature LEGO-compatible mounting holes and M3 screw holes for quick assembly and integration. **Unit Roller485** is fully open-source in both hardware and software, supporting motion control and parameter adjustment via **RS485** or **I2C** buses, and provides SWD and SWO debugging interfaces, further enhancing developer flexibility. This product is used in robotic joints, motion control, industrial automation, and visual demonstration projects.

Learn



Roller485 Unit

This tutorial will introduce you to the Unit Roller485 usage guide

Features

- Brushless DC motor control
- RS-485/I2C communication control
- Integrated OLED display
- RGB indicators
- FOC closed-loop drive system
- Slip ring

| Includes

- 1 x Unit Roller485
- 1 x HT3.96R-4P connector
- 2 x HY2.0-4P Grove cables (5cm)
- 6 x Friction pins
- 1 x Flange
- 1 x Bracket
- 1 x Hex key (2.5mm)
- 1 x Hex key (2mm)
- 6 x M3 nuts
- 2 x Hex socket head M3x14mm screws
- 4 x Hex socket head M3x14mm screws
- 4 x Hex socket head M3x12mm screws
- 1 x Single-ended terminal cable 5P debugging cable

| Applications

- Robotic joint control
- Smart manufacturing equipment
- Visual demonstrations

| Specifications

Specification	Parameters
MCU	STM32G431C8U6@Cortex-M4, 128KB-Flash, 32KB-SRAM, 170MHz
Motor Type	D3504 200KV brushless motor@diameter: 41mm
Driver Chip	DRV8311HRRWR
Angle Sensor	TLI5012BE1000
Communication Interfaces	1x PWR-485 (HT3.96-4P interface) 2x I2C (0x64)
Display	0.66-inch OLED display, resolution: 64 x 48, SPI communication
RGB LEDs	2x WS2812-2020
Motor Power Supply	PWR-485 (HT3.96-4P interface) @6-16V Grove port DC 5V Slip ring_Grove port DC 5V
Load	Load: 50g Motor speed: 2100rpm Current: DC 16V/225mA Load: 200g Motor speed: 1400rpm Current: DC 16V/601mA Load: 500g (maximum load) Motor speed: 560rpm Current: DC 16V/918mA No load: DC 16V/78mA
Standby Current	Grove port DC 5V@70mA RS-485 (HT3.96-4P interface) DC 16V@32mA
Output Torque	Grove port DC 5V: 0.021N.m/0.2kgf.cm@current 350mA RS485 (HT3.96-4P interface) DC 16V: 0.065N.m/0.66kgf.cm@current 927mA
Slip Ring (Grove port) Output	DC 5V/300mA
Noise	48dB
Operating Temperature	0 ~ 40°C
Product Size	40.0 x 40.0 x 40.0mm
Product Weight	82.9g
Package Size	102.0 x 73.0 x 51.0mm
Gross Weight	156.8g

Learn

The main difference between Unit-Roller485 Lite and Unit-Roller485 is that Unit-Roller485 Lite does not have a slip ring expansion Grove interface or the top LEGO expansion interface.

Power supply voltage

The power supply should not exceed 16V. If the voltage exceeds 18V, the motor will display a fault code E:1, the motor will not work, and "Over Voltage" will be displayed, with the LED turning red.

Encoder Value and Rotation Angle

In absolute position mode, the encoder value of 36000 pos corresponds to 360°. Due to the fact that the mechanical installation angle and the encoder angle are not strictly aligned, there may be an error of approximately 2°.

Schematics

- [Unit Roller485 Main Board Schematics PDF](#)
- [Unit Roller485 Top Ring Board Schematics PDF](#)

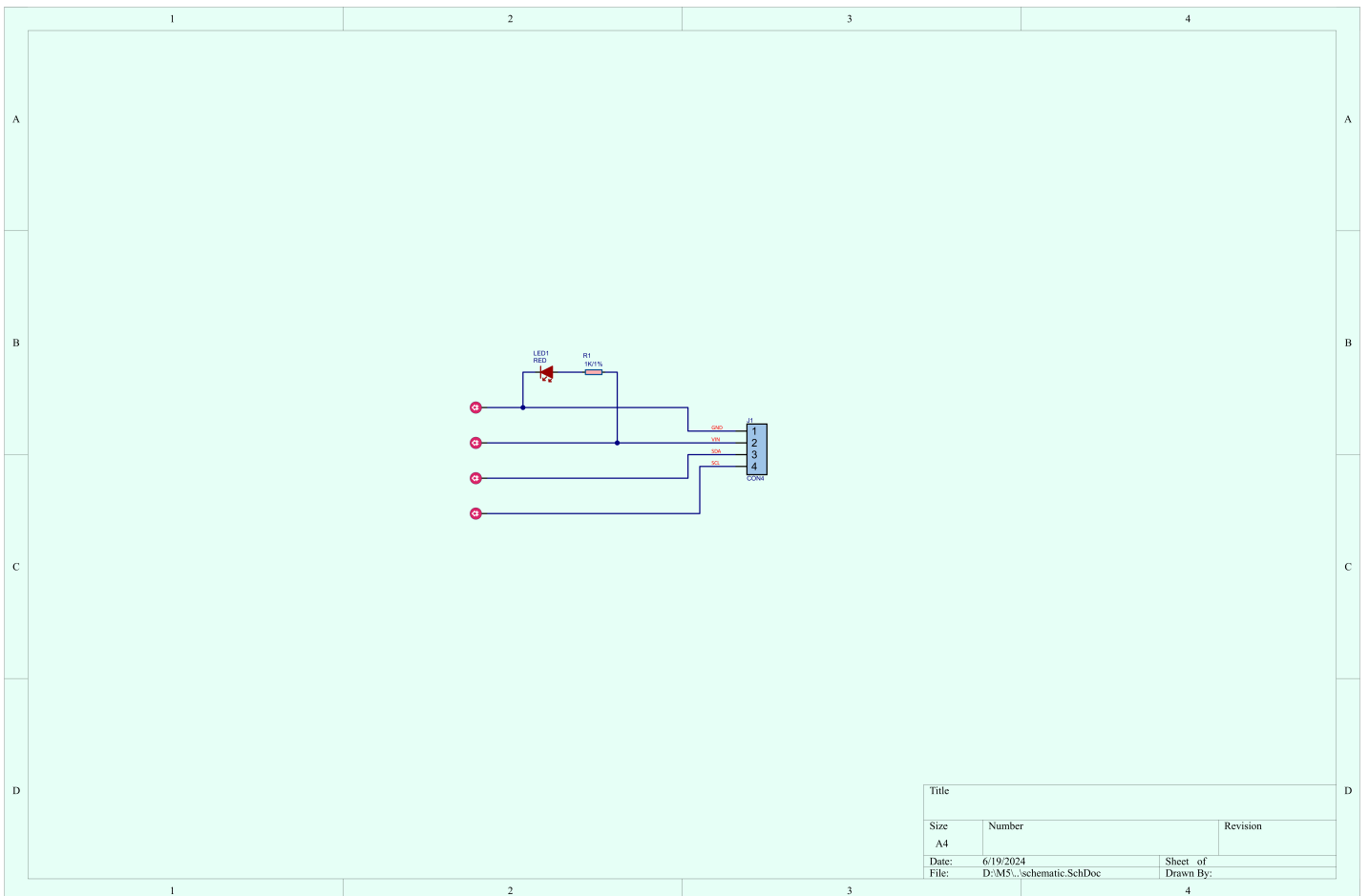
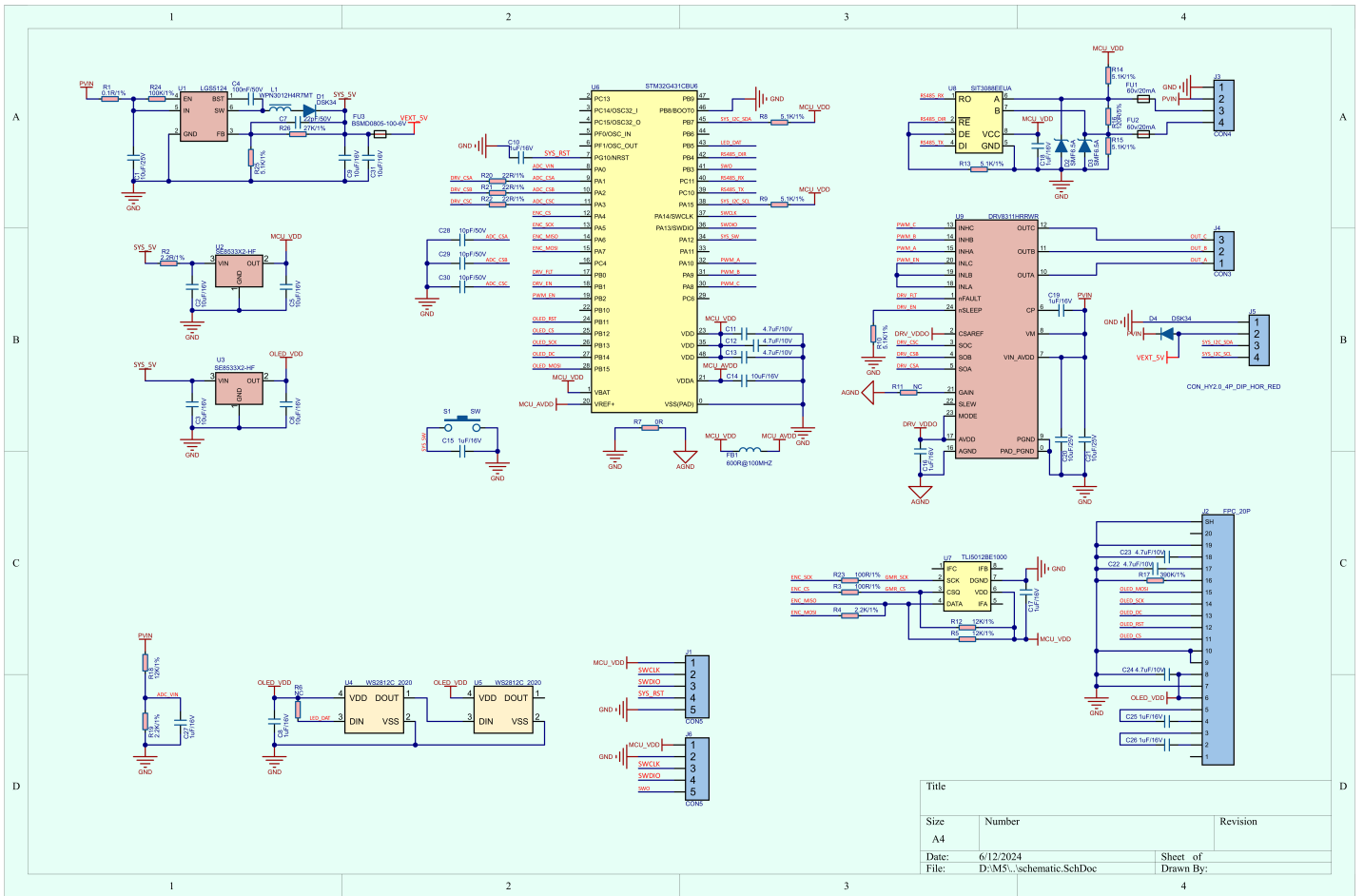

PinMap

Unit Roller485

HY2.0-4P	Black	Red	Yellow	White
PORT.A	GND	5V	SDA	SCL

I2C, PWR485, RGB, Button

STM32G431CBU6	PA15	PB7	PC11	PC10	PB4	PB5	PA12
I2C	SYS_I2C_SCL	SYS_I2C_SDA					
PWR485			RS485_RX	RS485_TX	RS485_DIR		
WS2812C						LED_DAT	
Button A							SYS_SW

OLED

STM32G431CBU6	PB15	PB13	PB14	PB11	PB12
OLED	OLED_MOSI	OLED_SCK	OLED_DC	OLED_RST	OLED_CS

Model Size

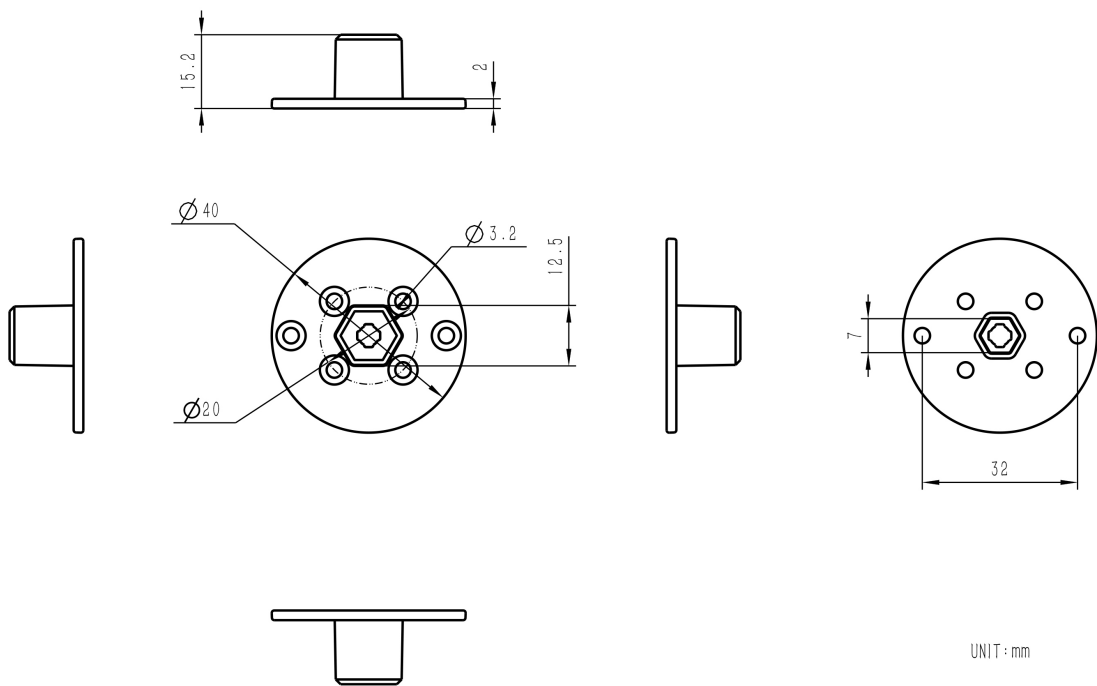
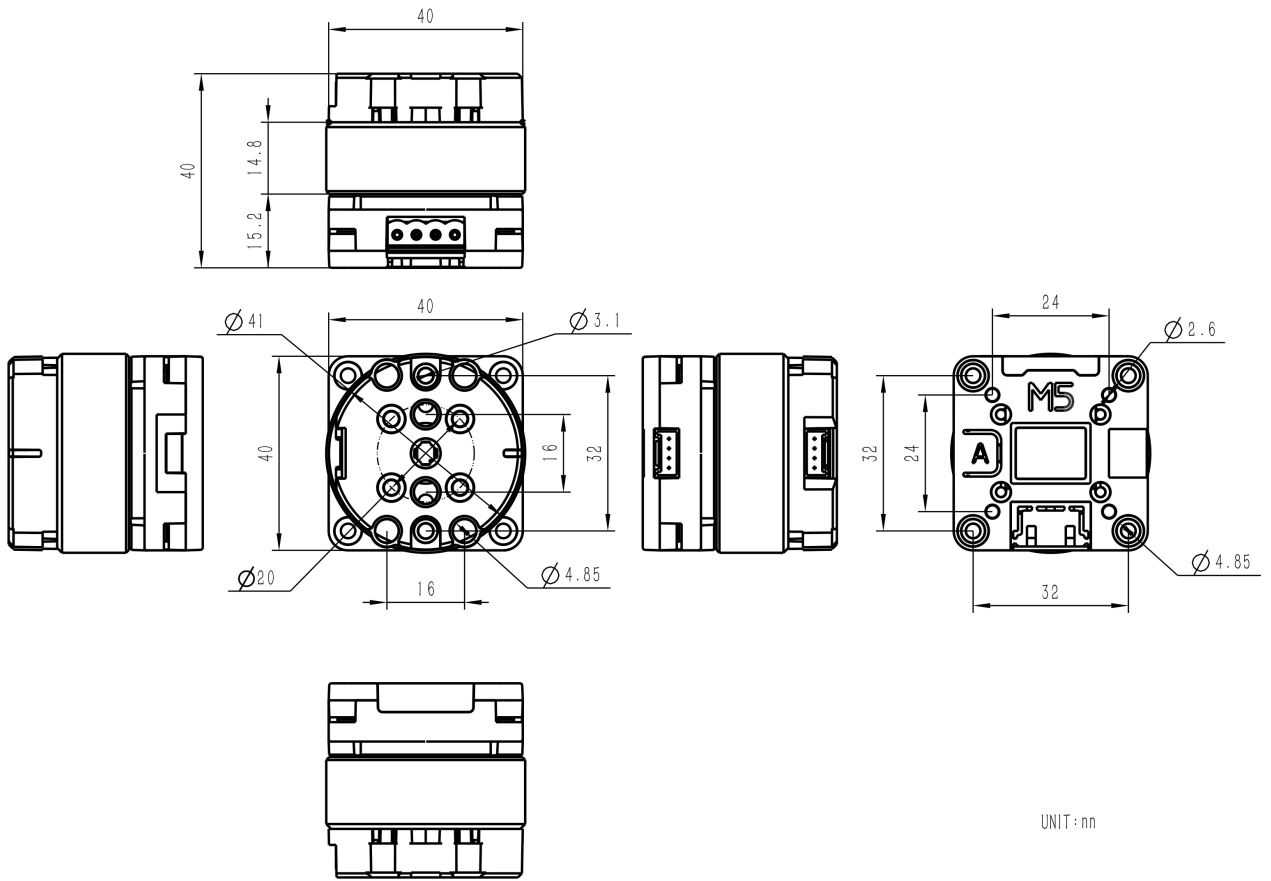

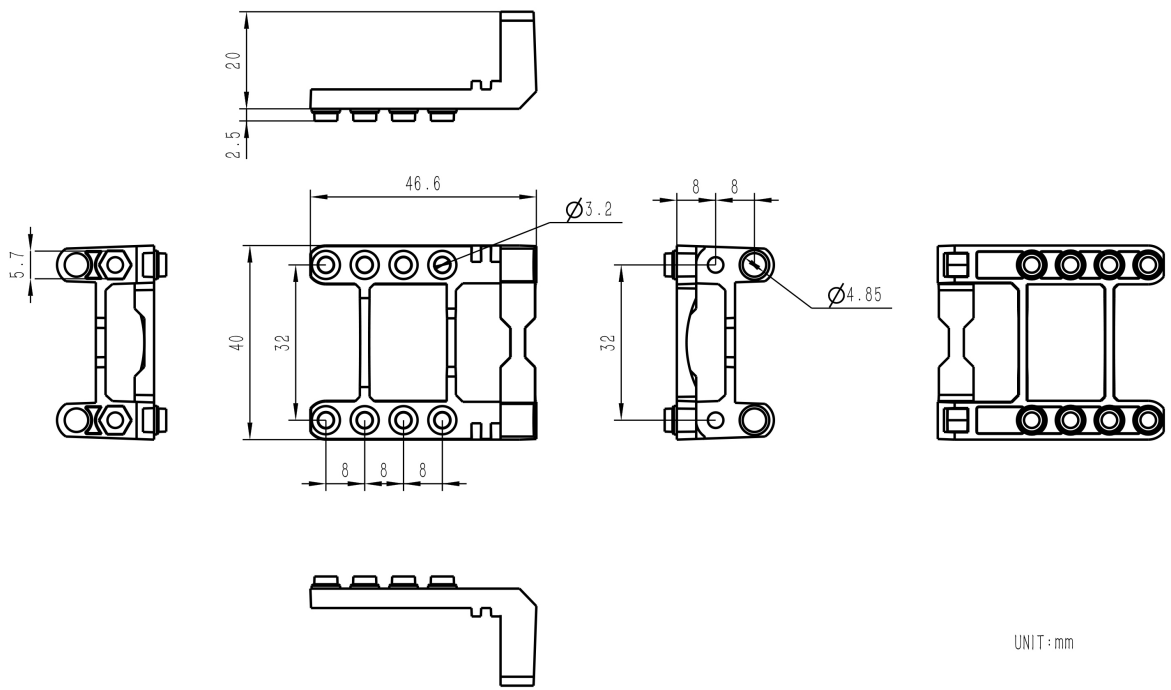

UNIT: mm

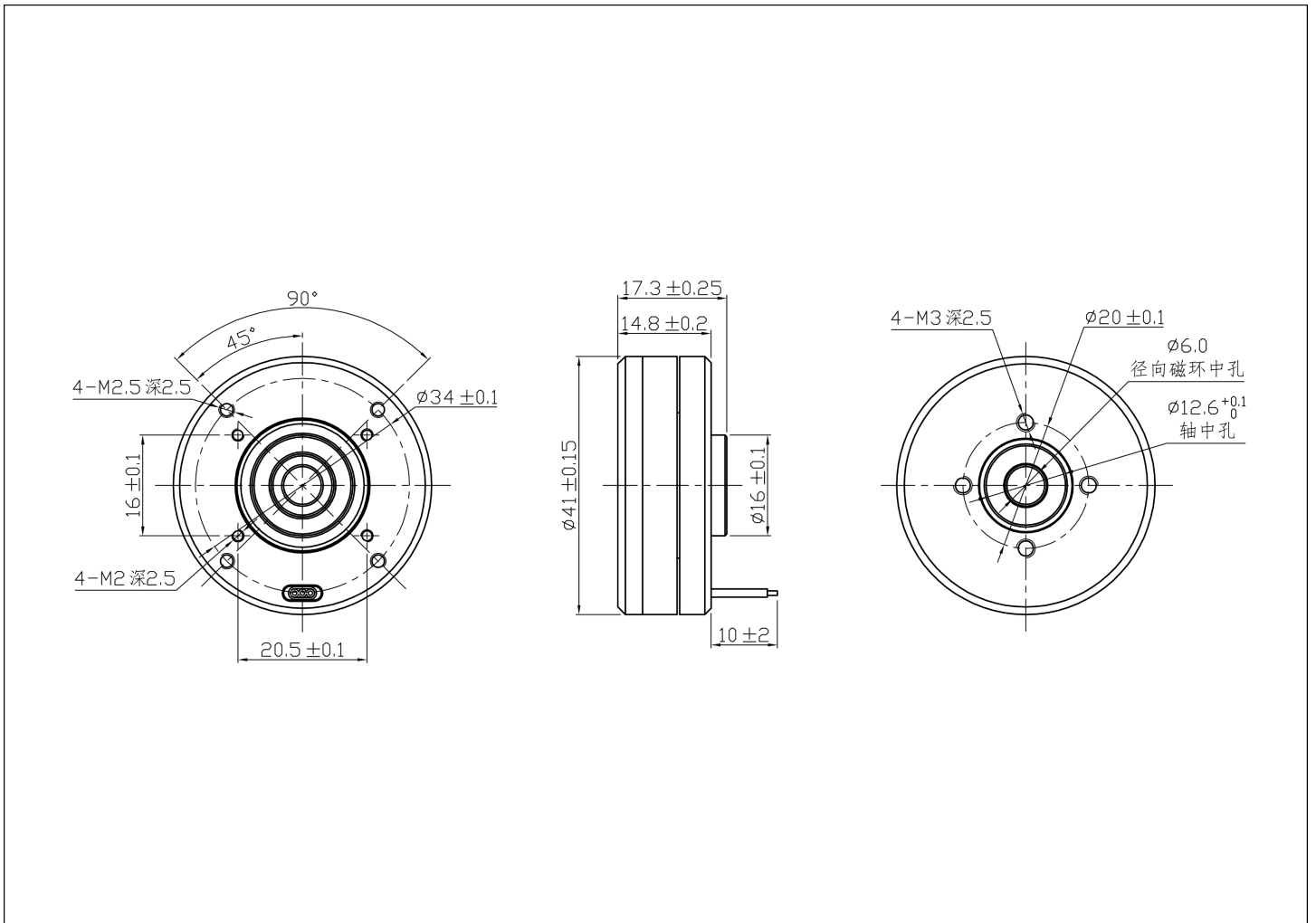

Datasheets

- [Angle Sensor TLI5012BE1000](#)
- [Motor Driver DRV8311HRRWR](#)

Softwares

Arduino

- [Unit Roller485 Arduino Library](#)

Internal Firmware

- [Unit Roller485 Internal Firmware](#)

Communication Protocols

- I2C Protocol
- [Unit Roller485 I2C Protocol](#)
- [Unit Roller485 I2C User Manual](#)
- RS485 Protocol
- [Unit Roller485 RS485 Protocol](#)

- [Unit Roller485 RS485 User Manual](#)

| UiFlow2

- [Unit Roller485 UiFlow2 Docs](#)

| Video

- [Unit Roller485 Product Introduction and Case Demonstration](#)

[3e5ec07a60735d6943fa7659b7978182.mp4](#)

- [UIFlow Use](#)