

Unit LoRaWAN-EU868

SKU: U184-EU868

UNIT
LoRaWAN
EU868

M5STACK

EU868
STM32WLE5

UART
INTERFACE

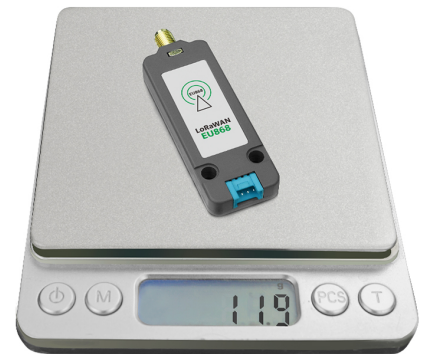

Description

Unit LoRaWAN-EU868 is a LoRaWAN communication module based on LoRa technology, specifically designed for the EU868 frequency band, suitable for Europe and other regions using the EU868 frequency band. The module adopts the **STM32WLE5** solution, supporting long-distance communication with low power consumption and high sensitivity. The module comes with a built-in LoRaWAN protocol stack, supporting **Class A, Class B, and Class C** operation modes. It also supports point-to-point (P2P) communication mode and uses a UART communication interface (controlled via AT commands) for flexible configuration. Additionally, the product features a high-performance **rubber duck antenna**, with an optimized antenna structure design, providing more stable signal coverage and longer communication distances, suitable for various complex environments. This module can be used as a collection node to connect to gateways for data collection and management, or for direct communication between devices in scenarios without gateways. It is used in long-distance, low-power IoT communication scenarios such as smart agriculture, industrial monitoring, and environmental monitoring node deployment.

Features

- Compliant with LoRaWAN® 1.0.3 protocol
- Supports EU868 frequency band
- Supports LoRa® P2P (Point-to-Point) communication
- LoRaWAN activation modes: OTAA, ABP
- Serial communication (AT commands)
- High-sensitivity rubber duck antenna
- Low power consumption
- Compatible with LEGO holes
- Development platforms:
 - UiFlow1
 - UiFlow2
 - Arduino IDE

Includes

- 1 x Unit LoRaWAN-EU868
- 1 x HY2.0-4P Grove cable (20cm)
- 1 x Rubber duck antenna (@2.8dBi, total length 195mm, SMA male connector)

Applications

- Smart agriculture
- Industrial monitoring
- Environmental monitoring node deployment

Specifications

Specification	Parameter
LoRa Solution	STM32WLE5 @256 KB Flash, 64 KB RAM
Supported Frequency Band	EU868 (868-870 MHz)
Protocol Support	LoRaWAN® 1.0.3 protocol (Class A, Class B, Class C)
Receiver Sensitivity	-137 dBm
LoRaWAN Activation Modes	OTAA, ABP
Communication Modes	LoRaWAN and Point-to-Point (P2P)
Communication Range (P2P)	2300m (125Kbps), 1300m (500Kbps)
Interface Type	UART serial port @ default baud rate 115200, supports AT commands
Antenna Type	High-performance rubber duck antenna, 50 ohms impedance @2.8dBi, total length 195mm, SMA male connector
Standby Power Consumption	Idle state: DC 5V/7.23mA
	Sleep state: DC 5V/28.61uA
Operating Current	(500Kbps) Data reception: DC 5V/9.20mA Data transmission: DC 5V/11.36mA (125Kbps) Data reception: DC 5V/8.43mA Data transmission: DC 5V/117.16mA
Operating Temperature	0 ~ 40°C
Product Size	71.4 x 24.0 x 8.0mm
Product Weight	11.9g
Package Size	243.0 x 93.0 x 9.0mm
Gross Weight	38.6g

Learn

Mode	Downlink Real-time Performance	Power Consumption	Application Scenarios
Class A	Lowest	Lowest	Periodic data upload, low-power sensors
Class B	Medium	Medium	Timed control devices
Class C	Highest	Highest	Real-time control devices, such as industrial automation

Certifications

- o [RAK3172 Module Certification Information](#)

Schematics

- o [Unit LoRaWAN-EU868 Schematic PDF](#)

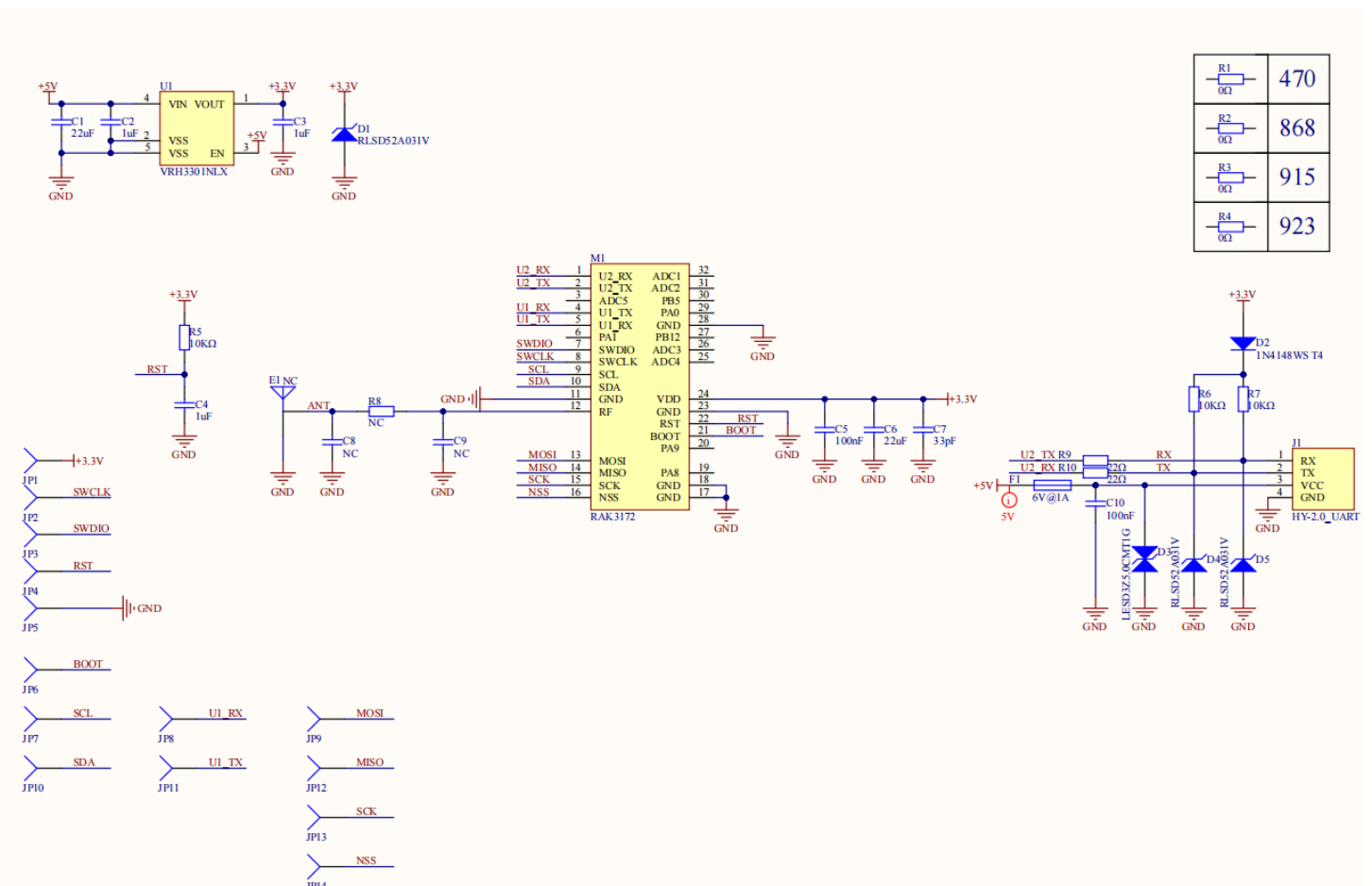

PinMap

Unit LoRaWAN-EU868

HY2.0-4P	Black	Red	Yellow	White
PORT.C	GND	5V	UART_RX	UART_TX

Model Size

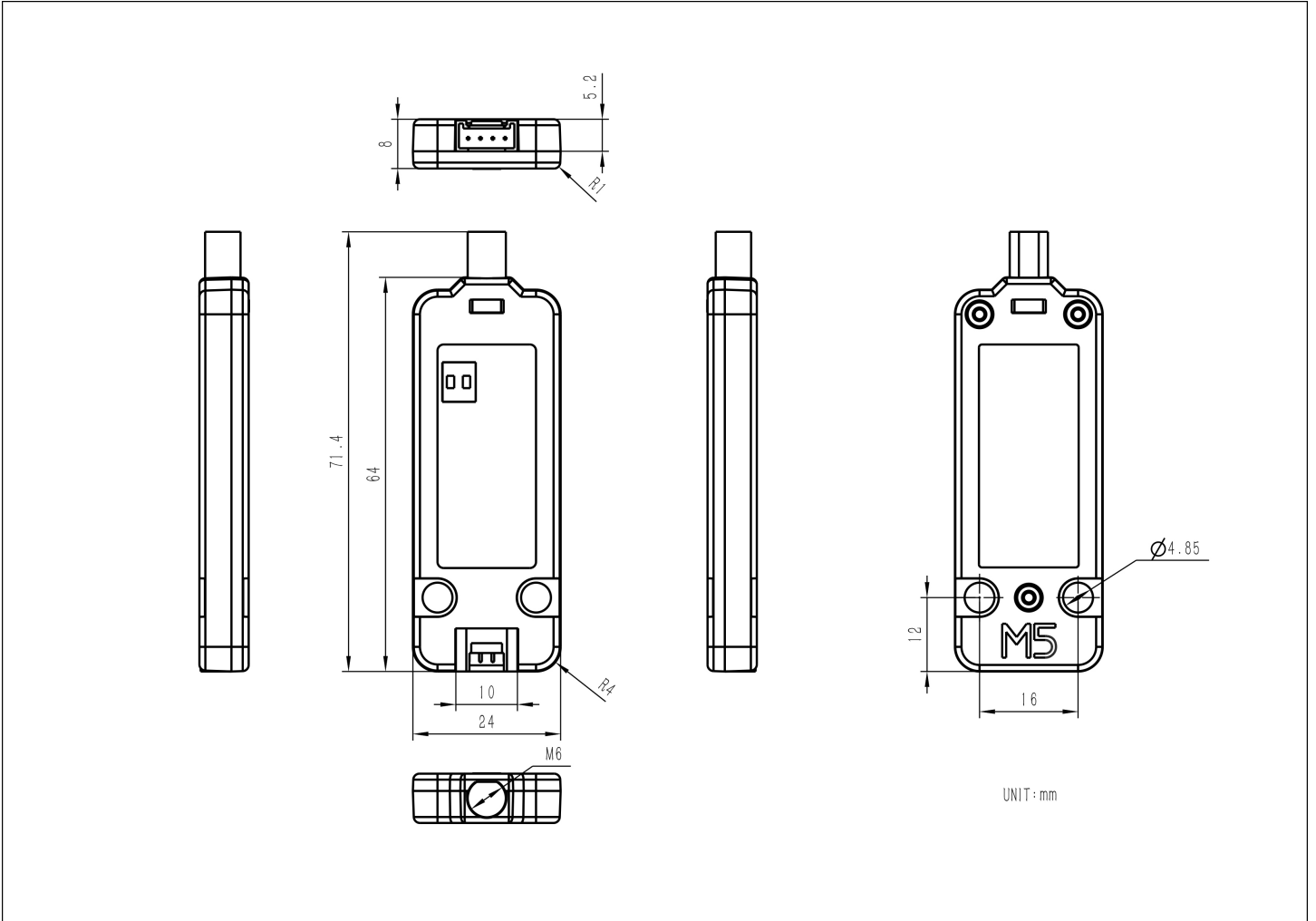

Datasheets

- [Unit LoRaWAN-EU868 Datasheet](#)

Softwares

Arduino

- [Unit LoRaWAN-EU868 Arduino Library](#)

UiFlow1

coming soon...

UiFlow2

coming soon...

Protocol

- [Unit LoRaWAN-EU868 AT Command Manual](#)

Video

- [Unit LoRaWAN-EU868 Product Introduction and Case Demonstration](#)

[LoRaWAN Video.mp4](#)

Product Comparison

Product Comparison



Unit LoRaWAN-EU868



Unit LoRaWAN 868MHz

	Unit LoRaWAN-EU868	Unit LoRaWAN 868MHz
Chip Module	STM32WLE5	ASR6501
Receiver Sensitivity	Minimum -137 dBm	Minimum -137 dBm
Interface Type	UART @ default baud rate: 115200	UART @ default baud rate: 115200
LoRaWAN Protocol Version	LoRaWAN 1.0.3, supports Class A/B/C	LoRaWAN 1.0.1, supports Class A/C
Transmit Power	Maximum 22 dBm	Maximum 21 dBm
Protocol Stack Support	Built-in LoRaWAN protocol stack	Built-in LoRaWAN protocol stack
Communication Modes	LoRaWAN and Point-to-Point (P2P)	LoRaWAN