

Unit Glass2

SKU:U158-B

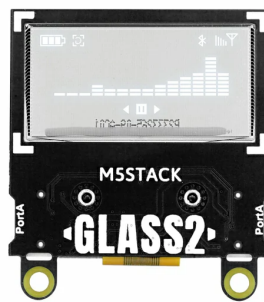
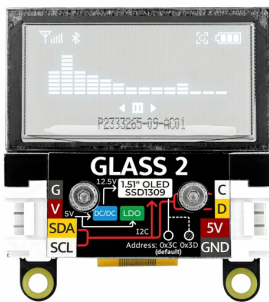
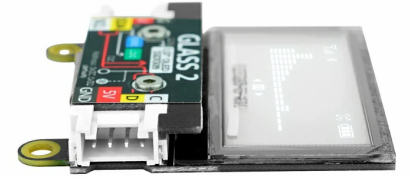
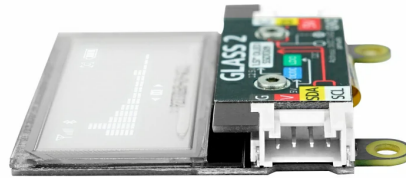
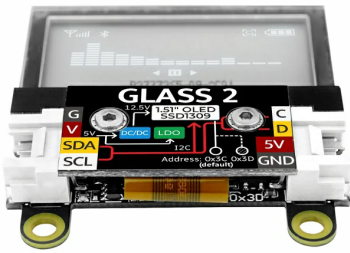

Description

Unit Glass2 is a 1.51-inch transparent OLED display expansion unit. It uses the SSD1309 driver and supports I2C communication (default address is 0x3C, which can be changed to 0x3D via the reserved solder pads). The screen offers excellent brightness and contrast, performing well under various lighting conditions. It is suitable for information display, status indication, or user interface integration, making it ideal for embedding into smart home products or control devices to enable user interaction.

Features

- 128x64 total pixels
- Display area: 35.05 x 18 mm
- Glass dimensions: 42.04 x 27.22 mm
- 1-bit color depth
- I2C communication (default address 0x3C, configurable to 0x3D)
- Supported programming platforms: Arduino, UiFlow

Includes

- 1 x Unit Glass2
- 1 x HY2.0-4P Grove cable (20 cm)

Applications

- Smart home products
- Control devices
- Display panels

Specifications

Specification	Parameter
Display	1.51-inch transparent OLED screen
Resolution	128 x 64
Display Color	Blue
Display Area	35.05 x 18 mm
Panel Size	42.04 x 27.22 x 1.25 mm
Viewing Angle	Full viewing angle
Operating Temp.	0 ~ 40°C
Logic Voltage	3.3V
Communication Interface	Default I2C Communication @0x3C, can be switched to 0x3D via solder pads
Product Size	53.0 x 42.0 x 6.0 mm
Product Weight	8.5 g
Package Size	138.0 x 93.0 x 7.0 mm
Gross Weight	14.3 g

Instructions

The two HY2.0-4P Grove ports on the left and right are interconnected and can be used interchangeably to connect other I2C devices. The default I2C address is **0x3C**, and it can be changed to **0x3D** via the reserved solder pads.



As shown in the image above, use a hex wrench to remove the two screws, then lift the top cover upward. Gently push the display's FPC cable aside to reveal two semicircular solder pads inside the circle. Apply solder to bridge the two pads to change the I2C address to **0x3D**. To revert to **0x3C**, simply remove the solder.

If the I2C address is changed to **0x3D**, make sure to update the corresponding configuration in your program as well.

Schematics

- [Unit Glass2 Schematics PDF](#)

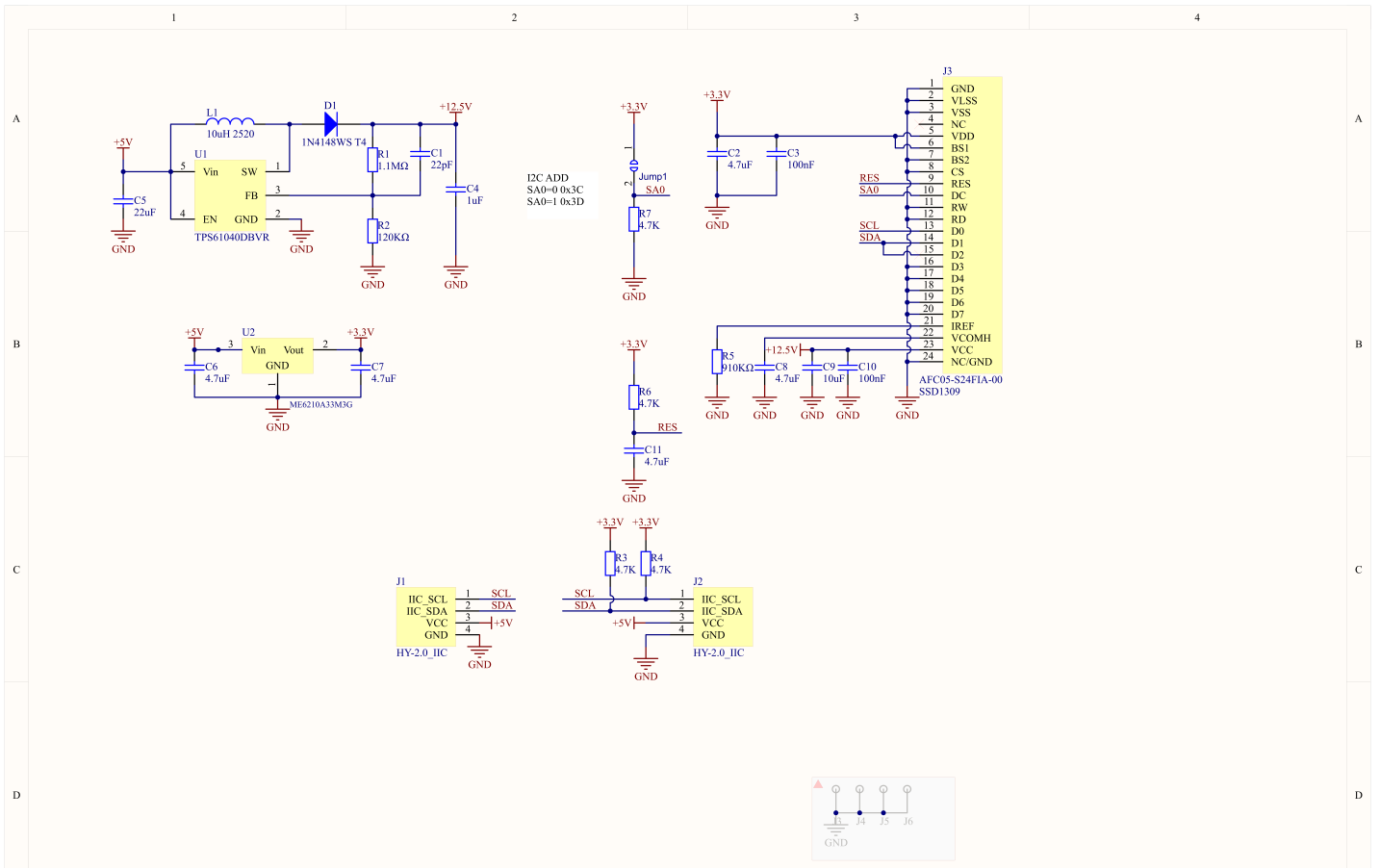

PinMap

Unit Glass2

HY2.0-4P	Black	Red	Yellow	White
PORT.A	GND	5V	SDA	SCL

Model Size

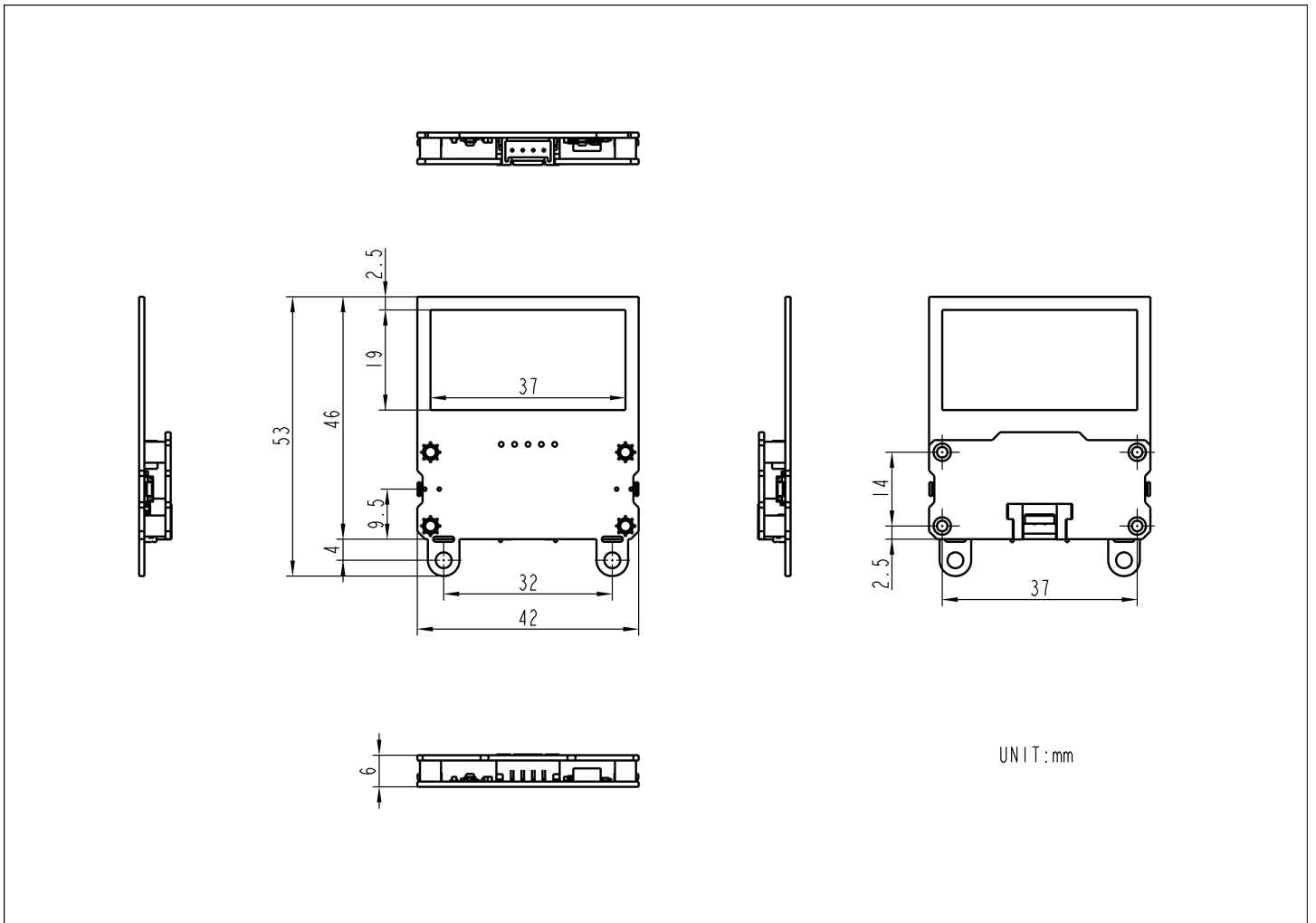

Datasheets

- [SSD1309](#)
- [128*64 Transparent OLED](#)

Softwares

Arduino

- [Unit Glass2 Arduino Tutorial](#)

UiFlow1

- [Unit Glass2 UiFlow1 Docs](#)

UiFlow2

- [Unit Glass2 UiFlow2 Docs](#)

Video

- [Unit Glass2 display example](#)

Product Comparison

Product Compare



Unit Glass2



Unit Glass

Chip Solution	STM32 + SSD1309	SSD1309
Hardware Interface	2 x HY2.0-4P Grove ports, no buttons or buzzer	1 x HY2.0-4P Grove port, 2 buttons, 1 buzzer
I2C Address	Fixed at 0x3D	0x3C / 0x3D (configurable via solder pads)