

AtomS3R-M12

SKU:C126-M12





Description

AtomS3R-M12 is an IoT programmable controller integrated with an **M12 camera**, equipped with a 3-megapixel **OV3660 wide-angle** camera, supporting high-resolution image capture. It uses the **ESP32-S3-PICO-1-N8R8** as the main controller, integrating Wi-Fi functionality, 8MB on-chip **Flash**, and 8MB **PSRAM**. It features a 5V to 3.3V power management circuit and includes a three-axis **BMM150** geomagnetic sensor and a six-axis **BMI270** attitude sensor. The product comes with **UVC** (USB Video Class) firmware, allowing it to be used as a driver-free USB camera, enabling users to use the camera directly via USB without installing drivers, and it has infrared emission control functionality. Compared to previous ATOM series host products, the **3D antenna** of **AtomS3R-M12** is enhanced, providing better performance and higher stability. The product also includes a **USB Type-C** interface for power supply and firmware download, and features a **HY2.0-4P** expansion port. The bottom is designed with six **GPIO** and power pins for easy expansion. With dimensions of only **24.0 x 24.0 x 22.1mm**, it is suitable for embedded scenarios such as IoT device monitoring and educational development tools.

Tutorial



Arduino IDE

This tutorial will introduce you to programming and controlling the AtomS3R-M12 device using the Arduino IDE

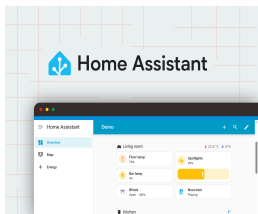

Home Assistant

This tutorial explains how to integrate AtomS3R-M12 into Home Assistant.

Features

- Integrated ESP32-S3-PICO-1-N8R8 main controller
- 3-megapixel OV3660 camera
- Nine-axis sensor system (BMI270 six-axis + BMM150 three-axis geomagnetic sensor)
- 8MB Flash and 8MB PSRAM
- Supports infrared emission control functionality
- Expandable pins and interfaces

- Development Platform
 - Arduino IDE
 - ESP-IDF
 - PlatformIO

Learn

BMM150 Magnetic Field Interference

Products with magnets may interfere with the BMM150 magnetic field sensor, causing abnormal readings. When used with an M5 master control device containing a magnet, the magnet needs to be removed, and at the same time, the BMM150 sensor should be kept away from strong magnetic fields.

Includes

- 1 x AtomS3R-M12

Applications

- Driver-free USB camera
- Motion detection and orientation awareness
- Smart device control
- IoT applications

Specifications

Specification	Parameter
SoC	ESP32-S3-PICO-1-N8R8@Dual-core Xtensa LX7, up to 240MHz
USB	USB OTG, USB Serial/JTAG
Flash	8MB
PSRAM	8MB
Wi-Fi	2.4 GHz Wi-Fi
Six-axis attitude sensor (BMI270)	Accuracy: 0.05% (acceleration), 0.05°/s (angular velocity) I2C Address: 0x68
Three-axis geomagnetic sensor (BMM150)	Accuracy: 0.3 μ T Mounted on BMI270, magnetometer data obtained through BMI270
Camera	Sensor Chip: OV3660 Max Frame Rate: 30 fps Output Format: RAW RGB, RGB565/555/444, CCIR656, YCbCr422, and compression Aperture: F2.4 Resolution: 3MP (3 megapixels) Focal Length: 1.8 \pm 5%mm Field of View: FOV 120°
Infrared IR	Infrared emission distance at \angle 180°: 12.46m (In the absence of obstruction)
Sleep Current	GPIO-5V Power: DC 5V@11.63 μ A Grove-5V Power: DC 5V@10.75 μ A USB-5V Power: DC 5V@92.50 μ A (including PD resistor loss)
Reserved GPIO at Bottom	G5/G6/G7/G8/G38/G39
Operating Temperature	0 ~ 40°C
Product Size	26.4 x 24.0 x 22.5mm
Product Weight	10.8g
Package Size	48.0 x 46.4 x 28.5mm
Gross Weight	17.3g

Learn

Download Mode

To flash firmware, press and hold the reset button (about 2 seconds) until the internal green LED lights up, then release. The device is now in download mode, ready for flashing.

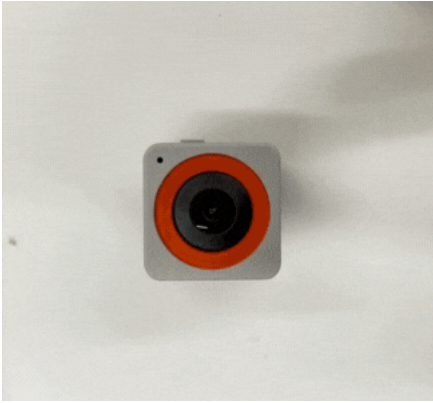

Schematics

- [AtomS3R-M12 main board Schematics PDF](#)
- [AtomS3R-M12 ext board Schematics PDF](#)

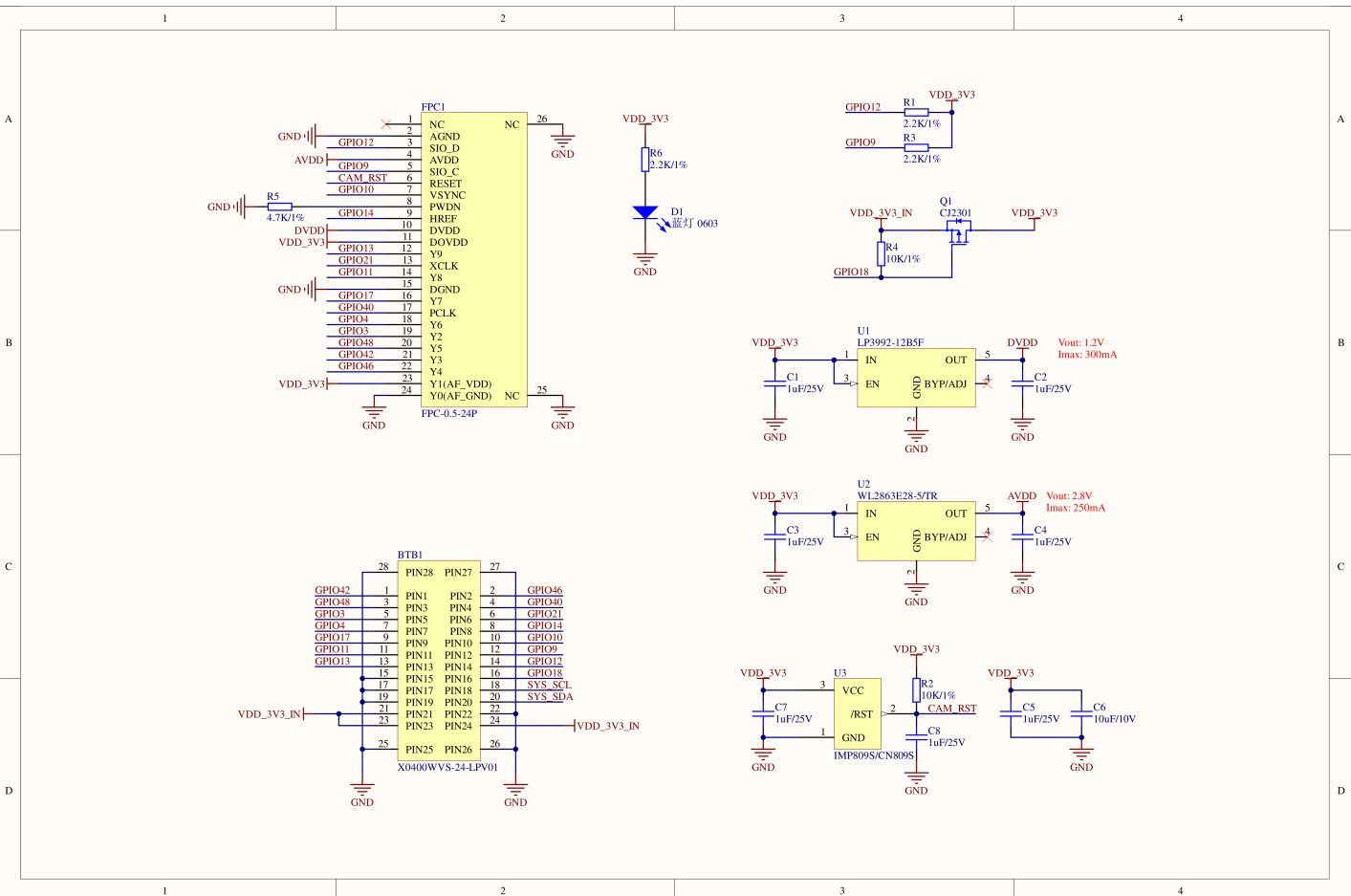
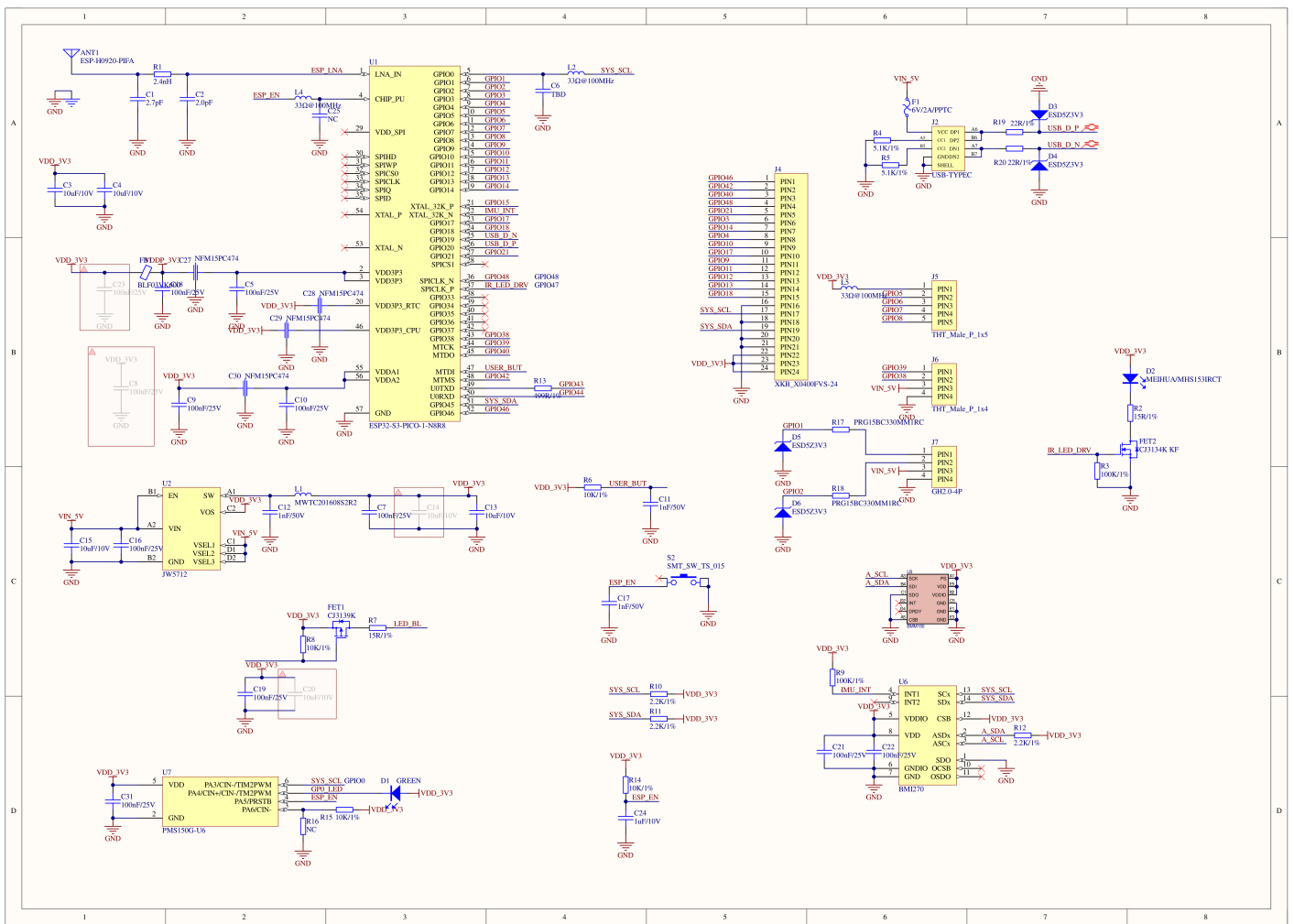

PinMap

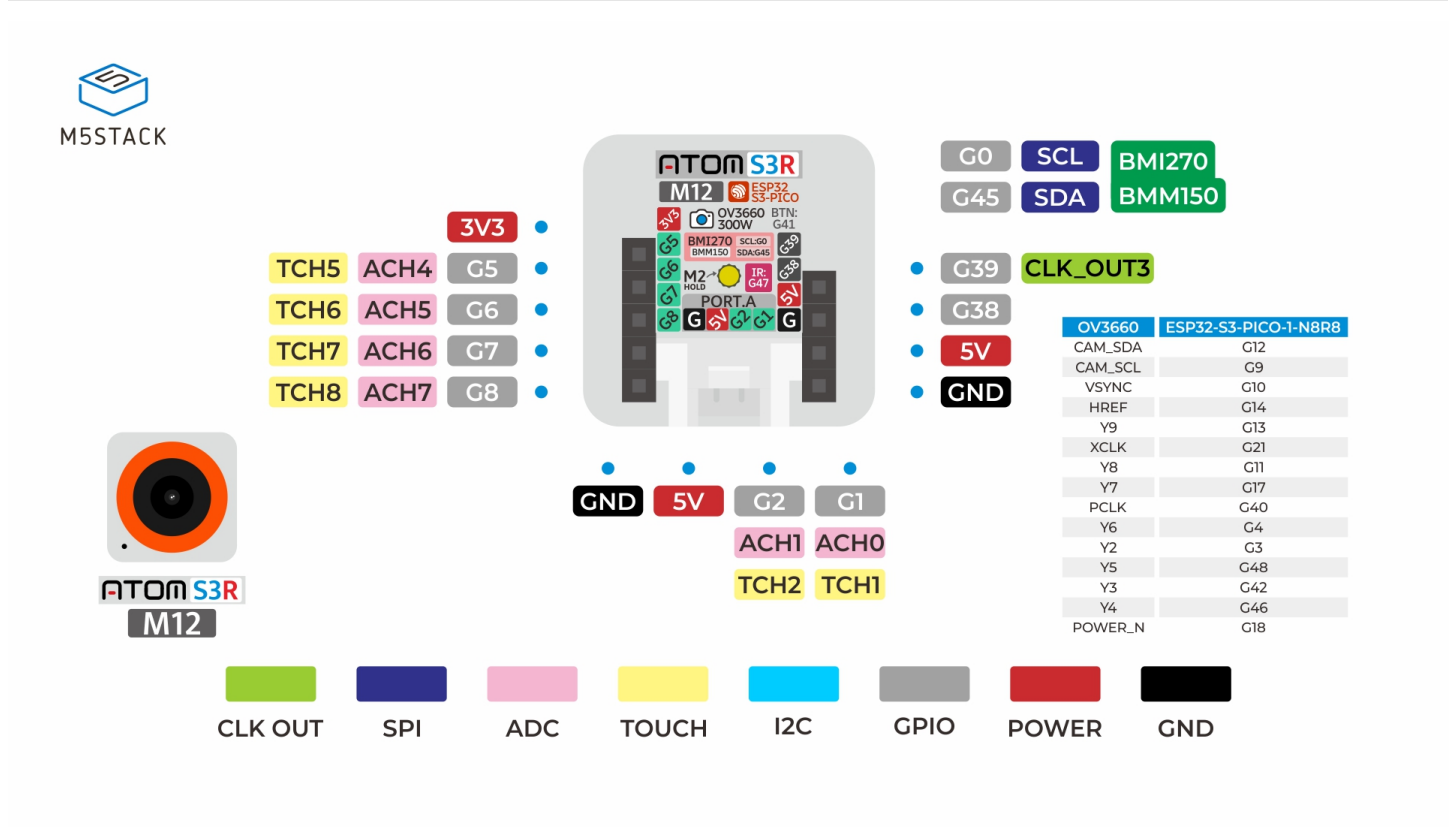

BMI270 & IR

ESP32-S3-PICO-1-N8R8	G0	G45	G47
BMI270	SYS_SCL	SYS_SDA	
IR			IR_LED_DRV

BMM150

BMI270	BMI270_ASDx	BMI270_ASCx
BMM150	A_SDA	A_SCL

BMM150 Mounted on BMI270

Integrating BMM150 via BMI270's Sensor Hub auxiliary I2C interface for unified 9-axis sensor data collection

OV3660(M12)

OV3360(M12)	ESP32-S3-PICO-1-N8R8
CAM_SDA	G12
CAM_SCL	G9
VSYNC	G10
HREF	G14
Y9	G13
XCLK	G21
Y8	G11
Y7	G17
PCLK	G40
Y6	G4
Y2	G3
Y5	G48
Y3	G42
Y4	G46
POWER_N	G18

HY2.0-4P

HY2.0-4P	Black	Red	Yellow	White
PORT.CUSTOM	GND	5V	G2	G1

Model Size

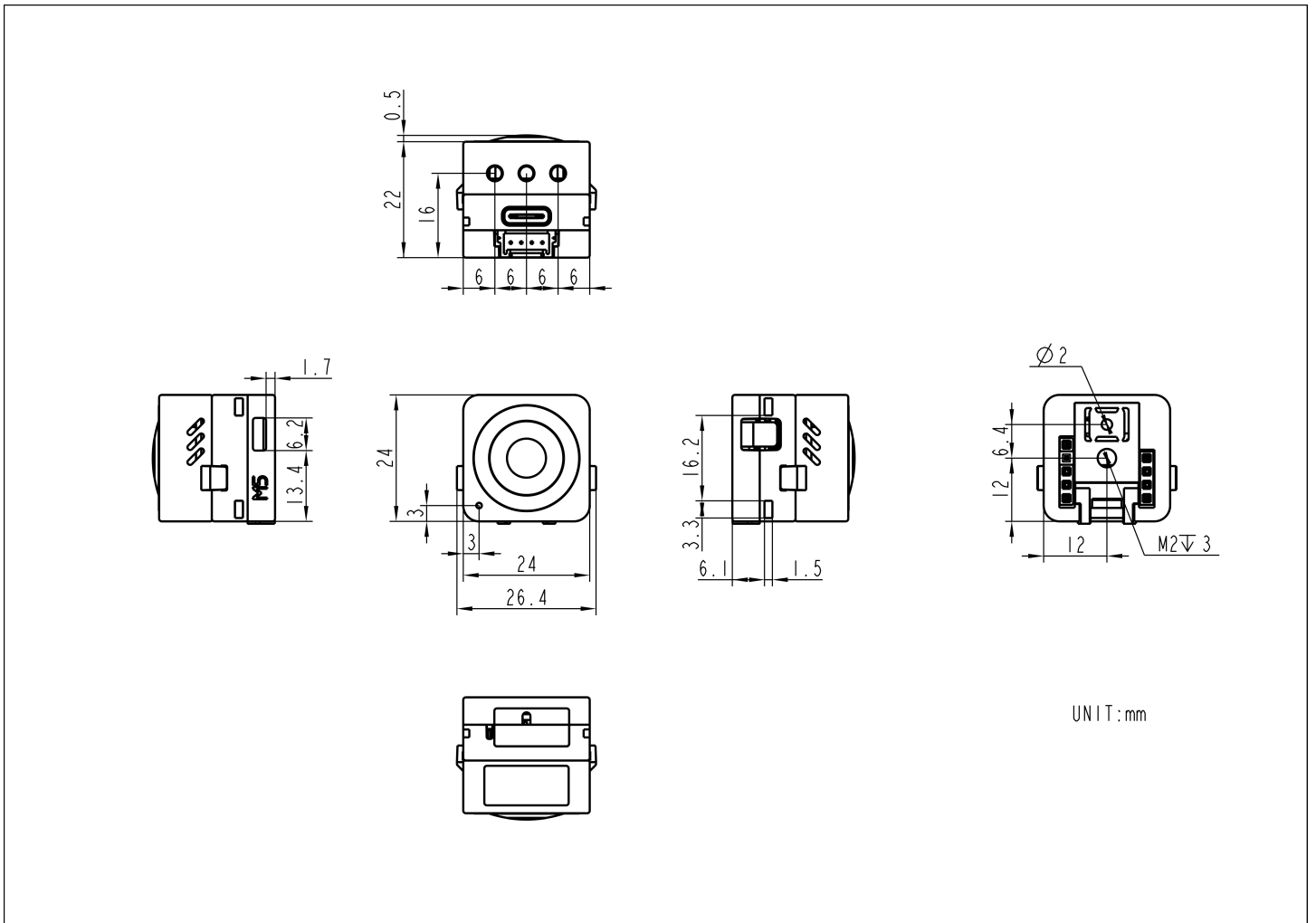

Datasheets

- [ESP32-S3-PICO-1-N8R8](#)
- [OV3660](#)
- [BMI270](#)
- [BMM150](#)

Softwares

Arduino

- [AtomS3R-M12 Arduino Quick Start](#)
- [AtomS3R-M12 Web Camera Example](#)

Home Assistant

- [Home Assistant Integration](#)

PlatformIO

```
[env:m5stack-atoms3r]
platform = espressif32@6.7.0
board = esp32-s3-devkitc-1
framework = arduino
board_build.arduino.memory_type = qio_opi
build_flags =
  -DESP32S3
  -DBOARD_HAS_PSRAM
  -mfix-esp32-psram-cache-issue
  -DCORE_DEBUG_LEVEL=5
  -DARDUINO_USB_CDC_ON_BOOT=1
  -DARDUINO_USB_MODE=1
lib_deps =
  M5Unified=https://github.com/m5stack/M5Unified
```

ESP-IDF

- [AtomS3R-M12 Factory Firmware](#)

Factory Firmware Functionality

The factory firmware provides **UVC** functionality and **Wi-Fi image transmission**.

UVC functionality allows direct USB connection to a computer, where you can preview images using a PC camera application.

For Wi-Fi image transmission, connect to the device's AP: AtomS3R-M12-WiFi, then enter 192.168.4.1 in a browser to access the image transmission preview page.

Easyloader

Easyloader	Download Link	Note
AtomS3R-M12 User Demo Easyloader	download	/

Video

- [AtomS3R-M12 Product Introduction and Case Demonstration](#)

[AtomS3R-M12-VIDEO.mp4](#)

Product Comparison

Product

Comparison



AtomS3R-M12

AtomS3R-Cam

Camera	<p>Image Sensor: OV3660</p> <p>Max Frame Rate: 30 fps</p> <p>Output Format: RAW RGB, RGB565/555/444, CCIR656, YCbCr422, and compression</p> <p>Aperture: F2.4</p> <p>Resolution: 3MP (3 megapixels)</p> <p>Focal Length: 1.8 ± 5% mm</p> <p>Field of View (FOV): 120°</p>	<p>Image Sensor: GC0308</p> <p>Max Frame Rate: 30 fps</p> <p>Output Format: YCbCr4:2:2, RGB565, Raw Bayer</p> <p>Aperture: F2.6</p> <p>Resolution: 0.3MP</p> <p>Sensor Size (Camera Diagonal Length): 1/6.5"</p> <p>Focal Length: 2.43mm</p> <p>Field of View (FOV): 57.6°</p>
	Resolution	3MP
Communication	Supports UVC and Wi-Fi communication methods	Supports UVC and Wi-Fi communication methods
SoC	ESP32-S3-PICO-1-N8R8	ESP32-S3-PICO-1-N8R8
Memory	8MB Flash + 8MB PSRAM	8MB Flash + 8MB PSRAM
Sensors	BMI270 + BMM150	BMI270 + BMM150
Antenna	Enhanced 3D antenna	Enhanced 3D antenna

To compare information on the Atom series products, you can visit the [Product Selection Table](#), check the target products, and get the comparison results. The selection table covers key information such as core parameters and functional features, and supports comparison of multiple products simultaneously.