

Chopper-Stabilized, Precision Hall-Effect Latches for Automotive, Consumer, and Industrial Applications

FEATURES AND BENEFITS

- Symmetrical switch points
- Resistant to physical stress
- Superior temperature stability
- Output short-circuit protection
- Operation from unregulated supply
- Reverse battery protection
- Solid-state reliability
- Small package size
- AEC-Q100 automotive qualified

APPLICATIONS

- Industrial motor/encoders
- Commutation/index sensing
- BLDC motors
- Fan motors
- Power tools
- Home applications
- Industrial equipment

PACKAGES:

Not to scale

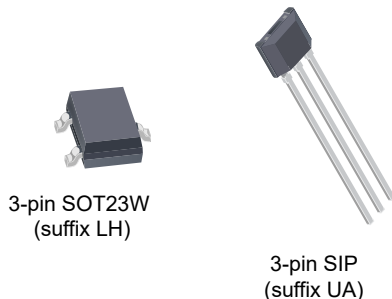

DESCRIPTION

The APS12202 and APS12212 Hall-effect latches are extremely temperature-stable and stress-resistant sensor ICs, especially suited for operation over extended temperature ranges (up to 150°C). Superior high-temperature performance is made possible through dynamic offset cancellation, which reduces the residual offset voltage normally caused by device package overmolding, temperature dependencies, and thermal stress. The two devices are identical except for their magnetic switch points.

Both devices include, on a single silicon chip, a voltage regulator, a Hall voltage generator, a small-signal amplifier, chopper stabilization, a Schmitt trigger, and a short-circuit protected open-drain output to sink up to 25 mA. A south polarity magnetic field of sufficient strength is required to turn the output on. A north polarity field of sufficient strength is necessary to turn the output off. An onboard regulator permits operation with supply voltages in the range of 3 to 24 V.

Two package styles provide a magnetically optimized package for most applications: type LH is a miniature SOT23W low-profile surface-mount package, and type UA is a three-pin ultramini SIP for through-hole mounting. Both packages are lead (Pb) free with 100% matte-tin leadframe plating.

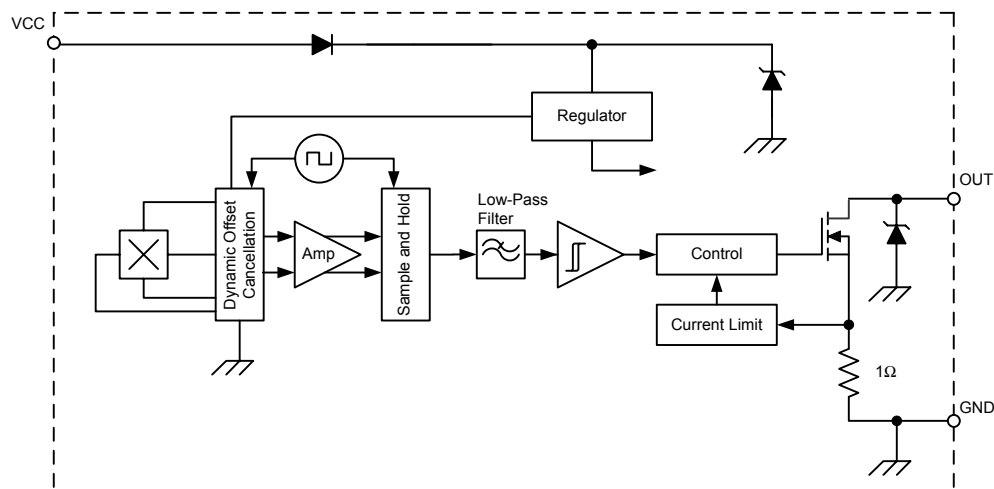

Functional Block Diagram

APS12202 and APS12212

Chopper-Stabilized, Precision Hall-Effect Latches for Automotive, Consumer, and Industrial Applications

SPECIFICATIONS

SELECTION GUIDE

Part Number	B _{OP} (typ)	B _{RP} (typ)	Ambient Temperature, T _A	Packaging	Branding	Packing
APS12202LLHALX	25 G	-25 G	-40°C to 150°C	3-Pin Surface-Mount SOT23W	AA6	13-in. reel, 10000 pieces/reel
APS12202LLHALT	25 G	-25 G	-40°C to 150°C	3-Pin Surface-Mount SOT23W	AA6	7-in. reel, 3000 pieces/reel
APS12202LUAA	25 G	-25 G	-40°C to 150°C	3-Pin Through-Hole SIP	AA5	Bulk, 500 pieces/bag
APS12212LLHALX	50 G	-50 G	-40°C to 150°C	3-Pin Surface-Mount SOT23W	AA7	13-in. reel, 10000 pieces/reel
APS12212LLHALT	50 G	-50 G	-40°C to 150°C	3-Pin Surface-Mount SOT23W	AA7	7-in. reel, 3000 pieces/reel
APS12212LUAA	50 G	-50 G	-40°C to 150°C	3-Pin Through-Hole SIP	AA3	Bulk, 500 pieces/bag



ABSOLUTE MAXIMUM RATINGS

Characteristic	Symbol	Notes	Rating	Units
Supply Voltage	V _{CC}		26.5	V
Reverse Battery Voltage	V _{RCC}		-20	V
Output Off Voltage	V _{OUT}		26	V
Continuous Output Current	I _{OUT}	Device provides internal current limiting to help protect itself from output short circuits	25	mA
Reverse Output Current	I _{ROUT}		-50	mA
Magnetic Flux Density	B		Unlimited	G
Operating Ambient Temperature	T _A	Range L	-40 to 150	°C
Maximum Junction Temperature	T _{J(max)}		165	°C
Storage Temperature	T _{stg}		-65 to 170	°C

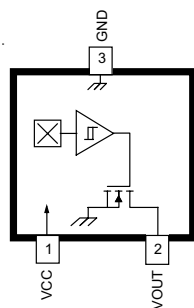

**Package LH,
3-Pin SOT23W Pinout
Diagram**

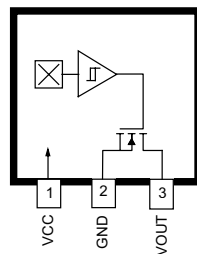

**Package UA,
3-Pin SIP Pinout
Diagram**

Terminal List

Name	Number		Function
	LH	UA	
VCC	1	1	Power supply
OUT	2	3	Output
GND	3	2	Ground

ELECTRICAL CHARACTERISTICS [1]: Over operating temperature range, unless otherwise noted

Characteristic	Symbol	Test Conditions	Min.	Typ. [2]	Max	Units
Supply Voltage Range [3]	V_{CC}	Operating, $T_J < 165^\circ\text{C}$	3.0	–	24	V
Output Leakage Current	I_{OFF}	$V_{OUT} = 24\text{ V}$, $B < B_{RP}$	–	–	10	μA
Output Saturation Voltage	$V_{OUT(SAT)}$	$I_{OUT} = 20\text{ mA}$, $B > B_{OP}$	–	185	500	mV
Output Current Limit	I_{ON}	$B > B_{OP}$	30	–	60	mA
Power-On Time	t_{PO}	$V_{CC} > 3.0\text{ V}$	–	–	25	μs
Chopping Frequency	f_C		–	800	–	kHz
Output Rise Time	t_R	$R_{LOAD} = 820\ \Omega$, $C_{LOAD} = 20\text{ pF}$	–	0.2	2.0	μs
Output Fall Time	t_F	$R_{LOAD} = 820\ \Omega$, $C_{LOAD} = 20\text{ pF}$	–	0.1	2.0	μs
Supply Current	I_{CC}	$B < B_{RP}$, $V_{CC} = 12\text{ V}$	–	2.0	3.0	mA
		$B > B_{OP}$, $V_{CC} = 12\text{ V}$	–	2.0	3.0	mA
Reverse Battery Current	I_{RCC}	$V_{RCC} = -20\text{ V}$	–	–	-5.0	mA
Zener Voltage	$V_Z + V_D$	$I_{CC} = 15\text{ mA}$, $T_A = 25^\circ\text{C}$	28	–	–	V
Zener Impedance	$Z_Z + Z_D$	$I_{CC} = 15\text{ mA}$, $T_A = 25^\circ\text{C}$	–	50	–	Ω

[1] Specifications guaranteed by design and verified by characterization. Not tested in production.

[2] Typical data at $T_A = 25^\circ\text{C}$, 12 V.

[3] Maximum V_{CC} must be derated for power dissipation and junction temperature. See application information.

MAGNETIC CHARACTERISTICS [4] [5]: Over V_{CC} range, unless otherwise noted

Characteristic	Symbol	Test Conditions		Min.	Typ.	Max.	Units
Operate Point [6]	B_{OP}	APS12202	$T_A = -40^\circ\text{C}$, 25°C , $T_{A(max)}$	5	25	50	G
		APS12212	$T_A = -40^\circ\text{C}$, 25°C , $T_{A(max)}$	15	50	90	G
Release Point [7]	B_{RP}	APS12202	$T_A = -40^\circ\text{C}$, 25°C , $T_{A(max)}$	-50	-25	-5	G
		APS12212	$T_A = -40^\circ\text{C}$, 25°C , $T_{A(max)}$	-90	-50	-15	G
Hysteresis ($B_{OP} - B_{RP}$)	B_{HYS}	APS12202	$T_A = 25^\circ\text{C}$ and $T_{A(max)}$	10	50	100	G
			$T_A = -40^\circ\text{C}$	–	–	100	G
		APS12212	$T_A = 25^\circ\text{C}$ and $T_{A(max)}$	30	100	180	G
			$T_A = -40^\circ\text{C}$	–	–	180	G

[4] The positive polarity symbol (+) indicates south magnetic field, and the negative polarity symbol (-) indicates north magnetic field.

[5] Specifications guaranteed by design and verified by characterization. Not tested in production.

[6] Required polarity observed and transition of magnetic gradient through B_{OP} . See "Functional Description".

[7] Required polarity observed and transition of magnetic gradient through B_{RP} after B_{OP} . See "Functional Description".

THERMAL CHARACTERISTICS: May require derating at maximum conditions; see application information

Characteristic	Symbol	Test Conditions [1]	Value	Units
Package Thermal Resistance	$R_{\theta JA}$	Package LH, 1-layer PCB with copper limited to solder pads	228	$^{\circ}\text{C}/\text{W}$
		Package LH, 2-layer PCB with 0.463 in. ² of copper area each side connected by thermal vias	110	$^{\circ}\text{C}/\text{W}$
		Package UA, 1-layer PCB with copper limited to solder pads	165	$^{\circ}\text{C}/\text{W}$

[1] Additional thermal information available on Allegro website.

Power Derating Curve

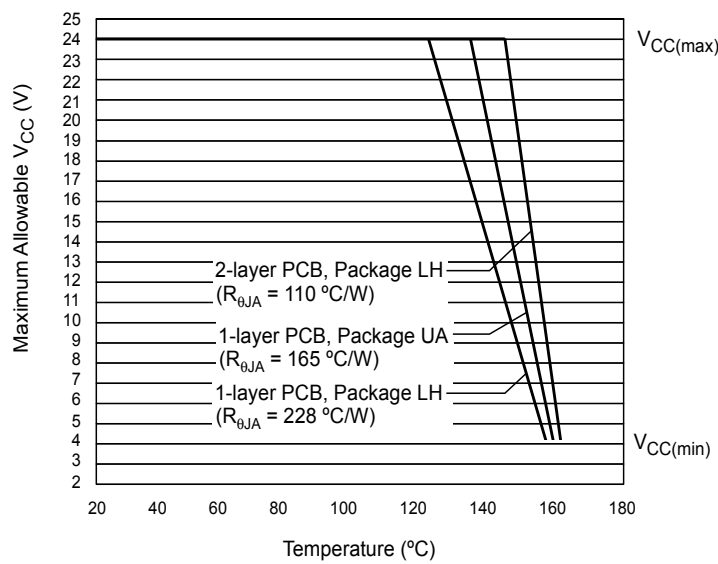

Power Dissipation versus Ambient Temperature

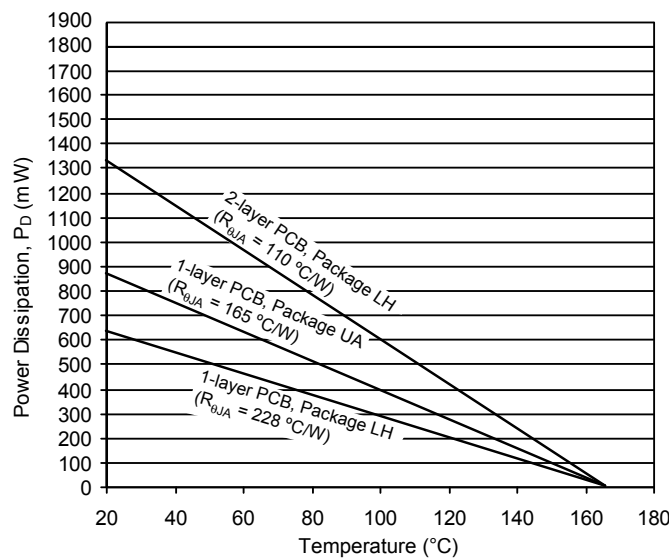

CHARACTERIZATION PLOTS

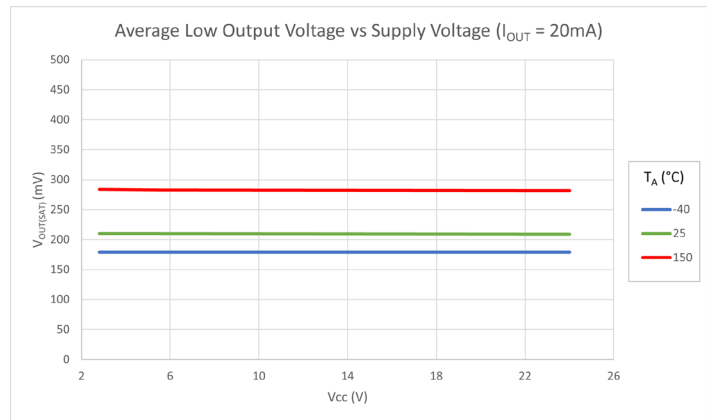
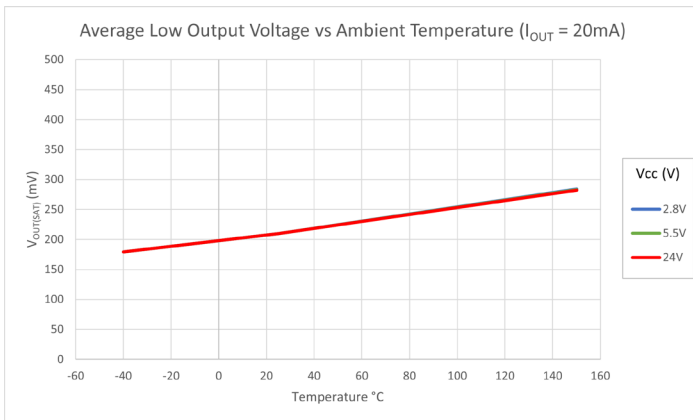
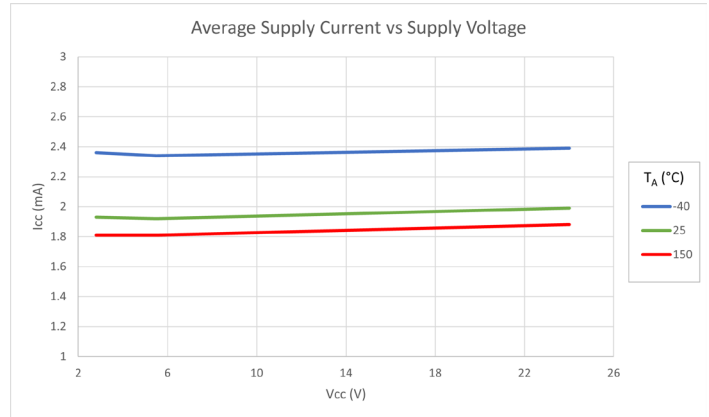
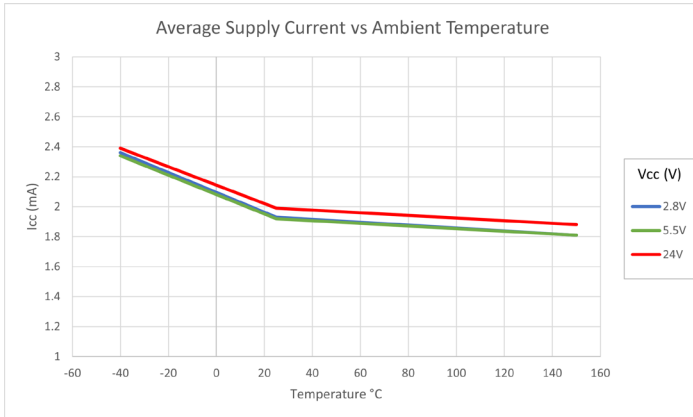

**CHARACTERIZATION PLOTS (Continued)
APS12202**

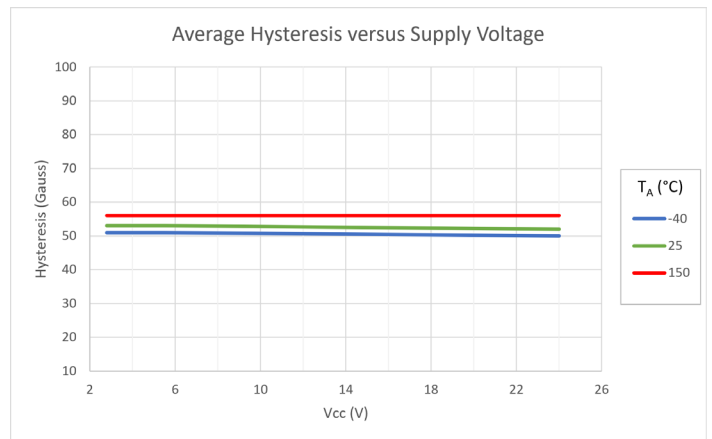
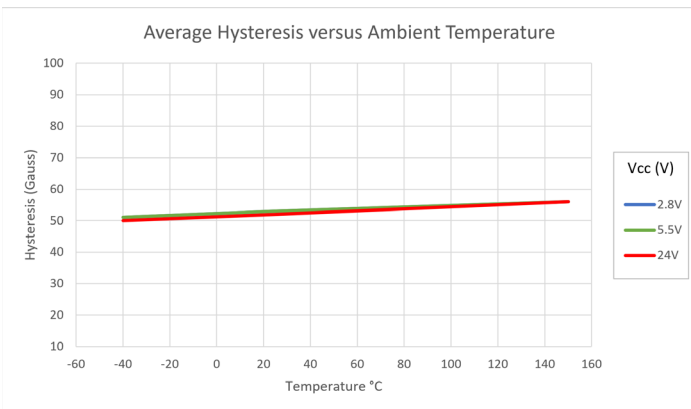
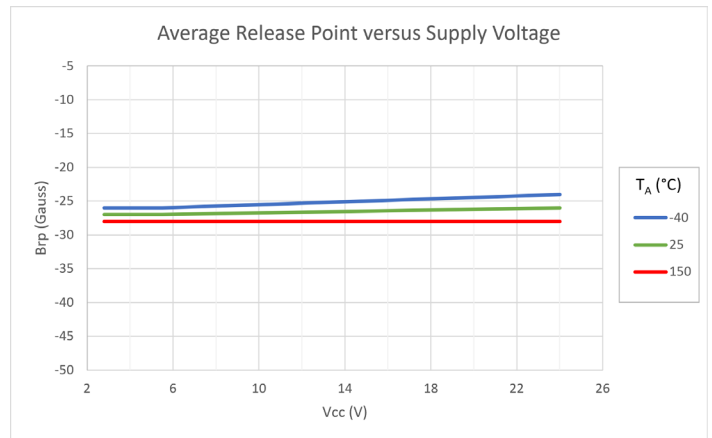
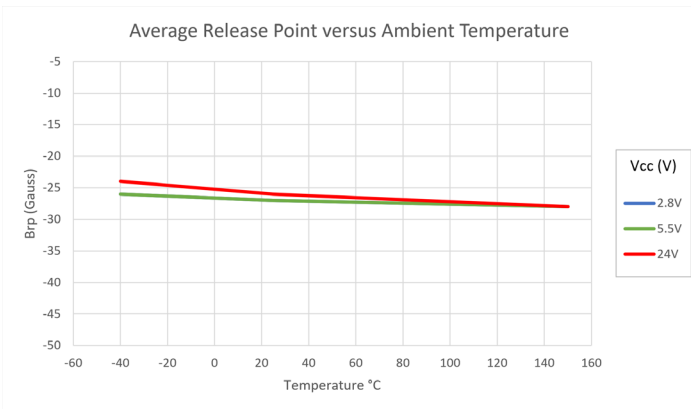
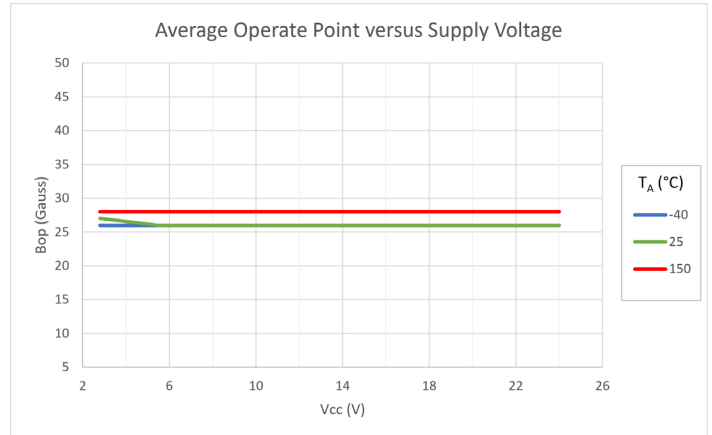
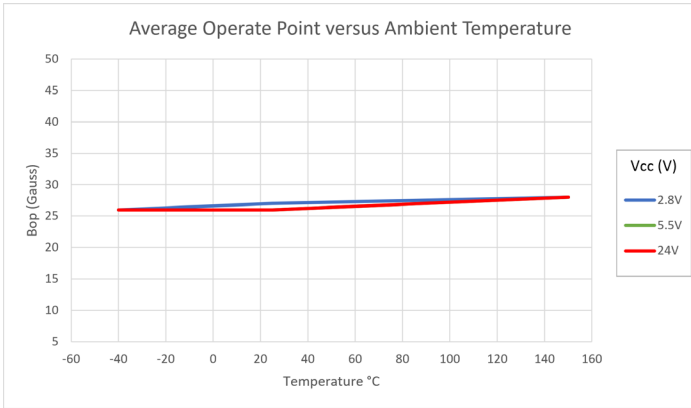

**CHARACTERIZATION PLOTS (Continued)
APS12212**

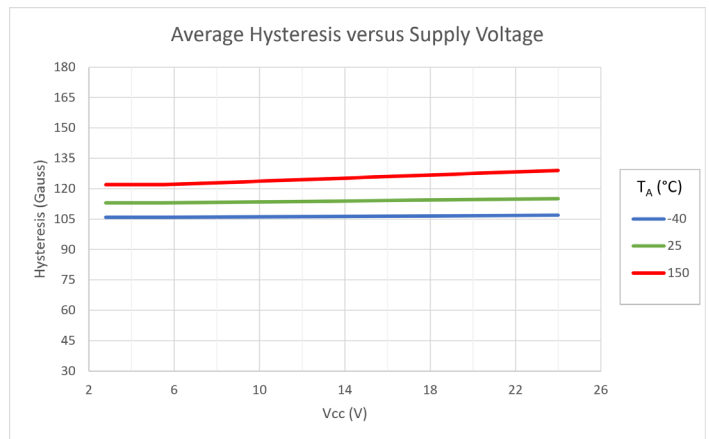
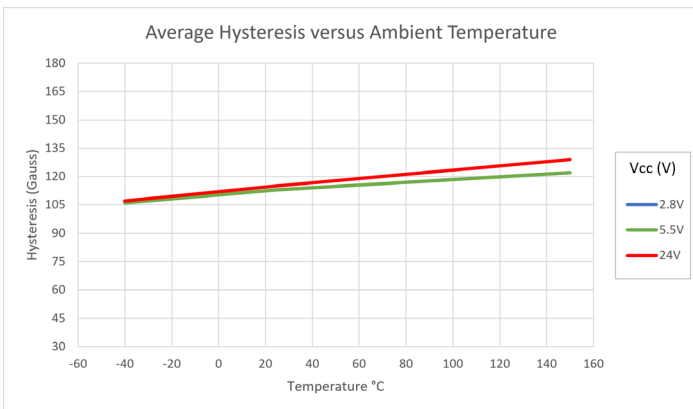
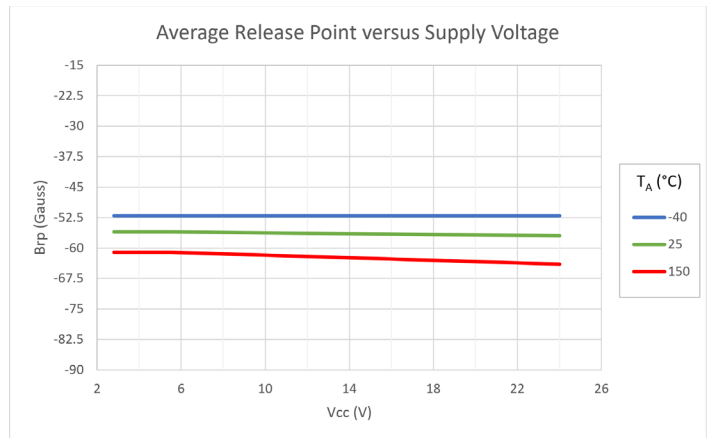
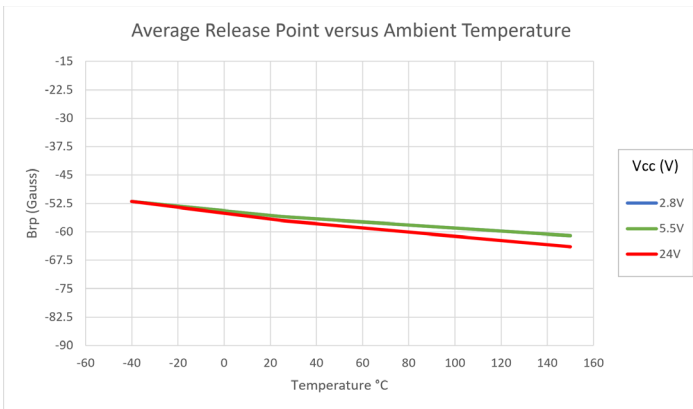
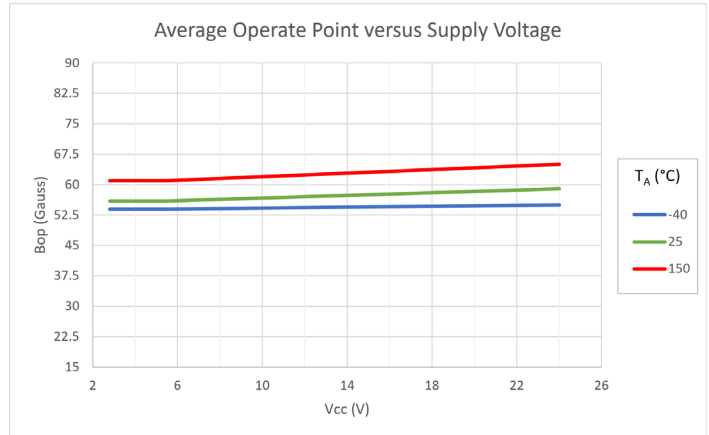
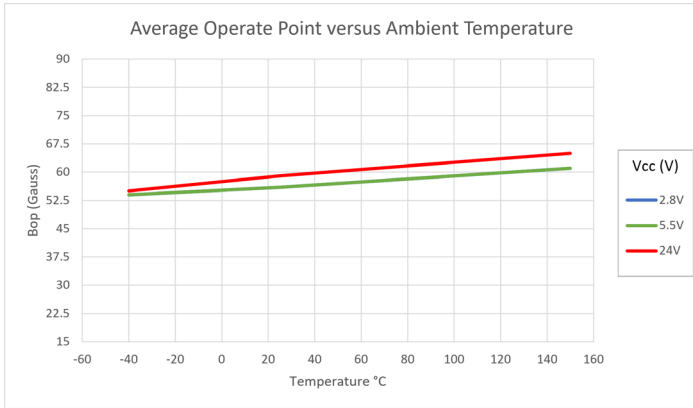

FUNCTIONAL DESCRIPTION

Chopper-Stabilized Technique

The Hall element can be considered as a resistor array similar to a Wheatstone bridge. A basic circuit is shown in Figure 1, demonstrating the effect of the magnetic field flux density (B) impinging on the Hall element. When using Hall-effect technology, a limiting factor for switch point accuracy is the small signal voltage (V_{HALL}) developed across the Hall element. This voltage is disproportionately small relative to the offset that can be produced at the output of the Hall device, caused by device overmolding, temperature dependencies, and thermal stress.

A large portion of the offset is a result of the mismatching of these resistors. The APS12202 and APS12212 use a dynamic offset cancellation technique, with an internal high-frequency clock, to reduce the residual offset. The chopper-stabilizing technique cancels the mismatching of the resistor circuit by changing the direction of the current flowing through the Hall element (refer to Figure 2). To do so, CMOS switches and Hall voltage measurement taps are used, while maintaining V_{HALL} signal that is induced by the external magnetic flux.

The signal is then captured by a sample-and-hold circuit and further processed using low-offset bipolar circuitry. This technique produces devices that have an extremely stable quiescent Hall output voltage, are immune to thermal stress, and have precise

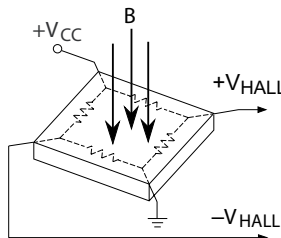
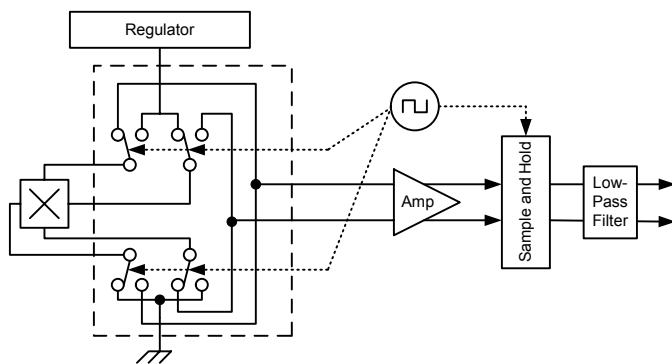

Figure 1: Hall Element, Basic Circuit Operation



**Figure 2: Chopper Stabilization Circuit
(Dynamic Quadrature Offset Cancellation)**

recoverability after temperature cycling. This technique will also slightly degrade the device output repeatability. A relatively high sampling frequency is used in order to process faster signals.

More detailed descriptions of the circuit operation can be found on the Allegro website, including: Technical Paper STP 97-10, *Mono-lithic Magnetic Hall Sensing Using Dynamic Quadrature Offset Cancellation*, and Technical Paper STP 99-1, *Chopper-Stabilized Amplifiers with a Track-and-Hold Signal Demodulator*.

Operation

The outputs of the APS12202 and APS12212 switch low (turn on) when a magnetic field perpendicular to the Hall element transitions through and exceeds the Operate Point threshold (B_{OP}). This is illustrated in Figure 3. After turn-on, the output is capable of sinking 25 mA, and the output voltage reaches $V_{OUT(SAT)}$.

Note that these devices latch; that is, after a south (+) polarity magnetic field of sufficient strength impinging on the branded face of the device turns on the device, the device remains on until the magnetic field is reduced below the Release Point threshold (B_{RP}). At that transition, the device output goes high (turns off). The difference in the magnetic operate and release points is the hysteresis (B_{HYS}) of the device. This built-in hysteresis allows clean switching of the output, even in the presence of external mechanical vibration and electrical noise.

When the devices are powered on, if the ambient magnetic field has an intensity that is between B_{OP} and B_{RP} , the initial output state is indeterminate. The first time that the level of B either rises through B_{OP} , or falls through B_{RP} , however, the correct output state is obtained.

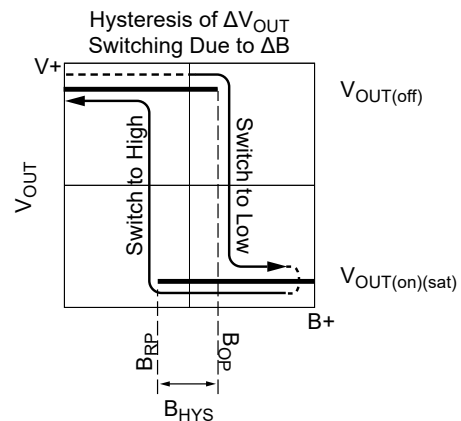

**Figure 3: Output Voltage Responds to
Sensed Magnetic Flux Density**

APPLICATION INFORMATION

It is strongly recommended that an external bypass capacitor be connected (in close proximity to the Hall element) between the supply and ground of the device to reduce both external noise and noise generated by the chopper stabilization technique. This configuration is shown in Figure 4.

The simplest form of magnet that will operate these devices is a ring magnet. Other methods of operation, such as linear magnets, are possible.

The device must be operated below the maximum junction temperature of the device ($T_{J(max)}$). Under certain combinations of peak conditions, reliable operation may require derating supplied power or improving the heat dissipation properties of the application. The Package Thermal Resistance ($R_{\theta JA}$) is a figure of merit summarizing the ability of the application and the device

to dissipate heat from the junction (die), through all paths to the ambient air. Its primary component is the Effective Thermal Conductivity (K) of the printed circuit board, including adjacent devices and traces. Radiation from the die through the device case ($R_{\theta JC}$) is relatively small component of $R_{\theta JA}$. Ambient air temperature (T_A) and air motion are significant external factors, damped by overmolding. Sample power dissipation results are given in the Thermal Characteristics section. Additional thermal data is also available on the Allegro website.

Extensive applications information for Hall-effect devices is available in: *Hall-Effect IC Applications Guide*, Application Note 27701 and *Guidelines for Designing Subassemblies Using Hall-Effect Devices*, Application Note 27703.1.

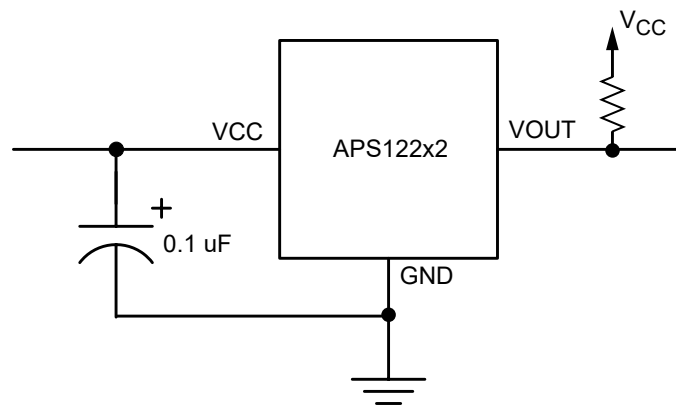

Figure 4: Typical Basic Application Circuit
A bypass capacitor is highly recommended.

PACKAGE OUTLINE DRAWINGS

For Reference Only – Not for Tooling Use

(Reference Allegro DWG-0000628, Rev. 1)

NOT TO SCALE

Dimensions in millimeters

Dimensions exclusive of mold flash, gate burrs, and dambar protrusions

Exact case and lead configuration at supplier discretion within limits shown

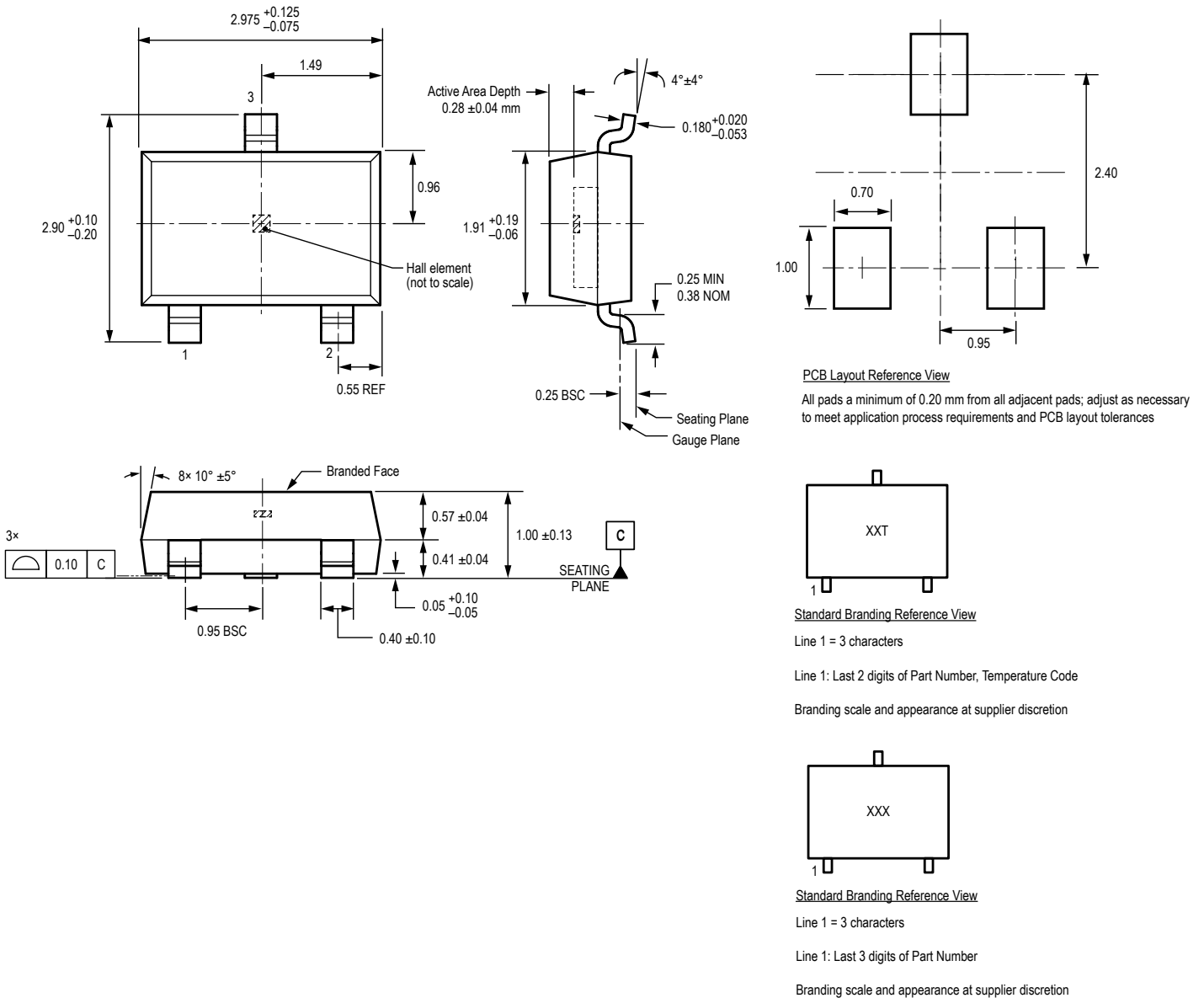
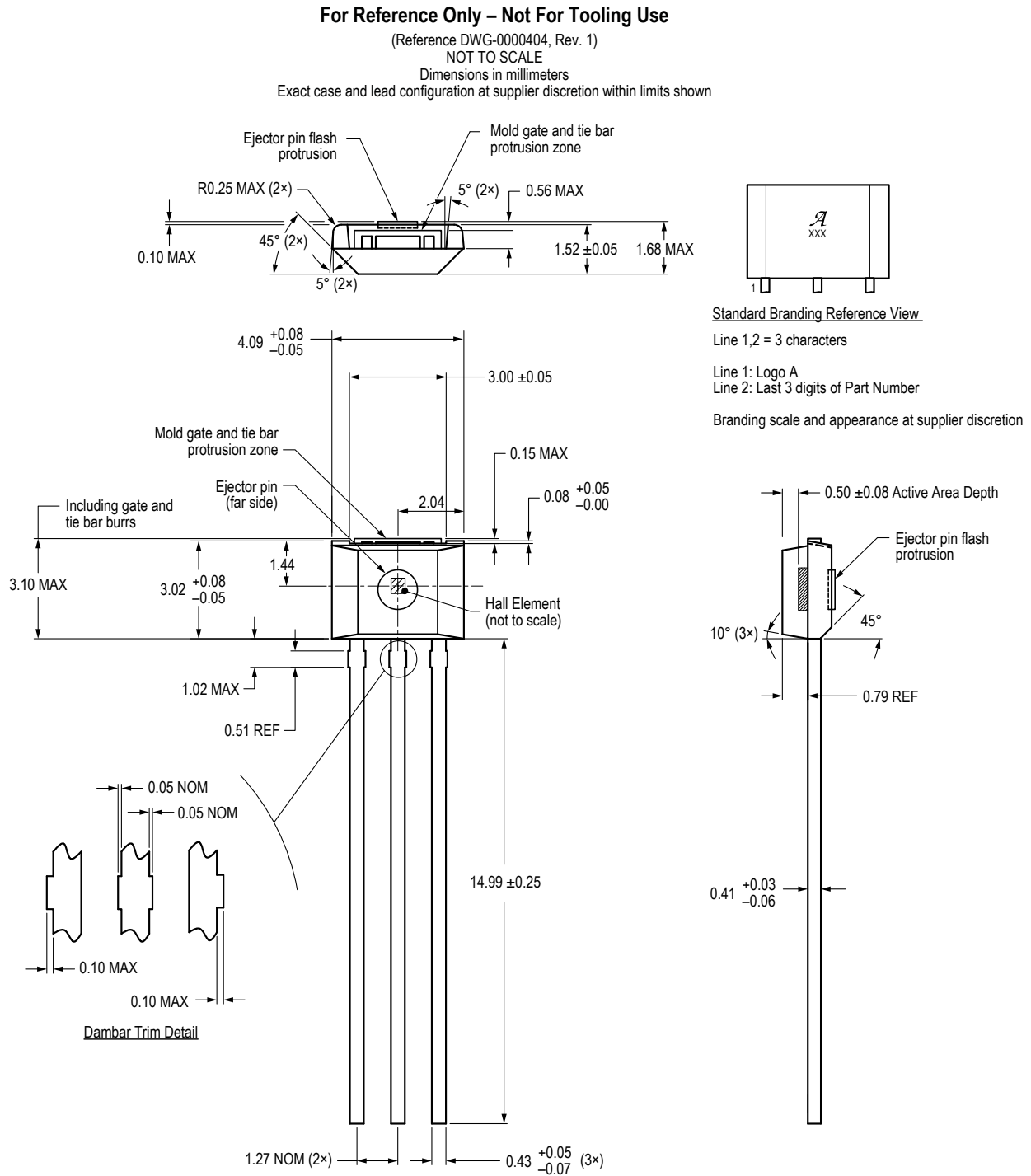

Figure 5: Package LH, 3-Pin SOT23W



Revision History

Number	Date	Description
–	March 15, 2023	Initial release
1	July 18, 2023	Added availability footnote to UA packages in selection guide (page 2)
2	June 17, 2024	Removed footnote from selection guide (page 2)
3	October 27, 2025	Corrected selection guide B_{OP}/B_{RP} values to match magnetic characteristics table typical values (page 2)

Copyright 2025, Allegro MicroSystems.

Allegro MicroSystems reserves the right to make, from time to time, such departures from the detail specifications as may be required to permit improvements in the performance, reliability, or manufacturability of its products. Before placing an order, the user is cautioned to verify that the information being relied upon is current.

Allegro's products are not to be used in any devices or systems, including but not limited to life support devices or systems, in which a failure of Allegro's product can reasonably be expected to cause bodily harm.

The information included herein is believed to be accurate and reliable. However, Allegro MicroSystems assumes no responsibility for its use; nor for any infringement of patents or other rights of third parties which may result from its use.

Copies of this document are considered uncontrolled documents.

For the latest version of this document, visit our website:

www.allegromicro.com