

## 3D Linear Hall-Effect Sensor with SPI, I<sup>2</sup>C Interfaces, and Advanced Low-Power Management

### FEATURES AND BENEFITS

- Flexible operating modes
  - Can measure input in any 1, 2, or 3 axes
  - 15-bit angle output from any selectable 2-axes plane
- Low RMS angle noise for high system resolution
- SPI and I<sup>2</sup>C interfaces for easy system integration
  - Up to 10 MHz SPI and 1 MHz I<sup>2</sup>C
- Ideal for battery-powered, low-voltage applications
  - 2.65 to 3.6 V analog supply operation
  - 1.8 to 3.6 V digital supply operation
  - Low leakage sleep I<sub>CC</sub>
  - Low-power duty cycle mode options for additional power savings
- Flexible multifunction pin for interrupt and sample-start functionality
  - Interrupt pin provides digital output when user-defined threshold has been exceeded
- On-chip EEPROM for storing factory and customer-configured settings
- Low-profile 3 mm × 3 mm DFN package for space-constrained applications
- -40°C to 85°C operation

### APPLICATIONS

- Camera gimbals
- Gamepad joysticks
- Motor control feedback
- RC autonomous vehicles
- Robotic position sensing
- Industrial motor control

### DESCRIPTION

The A31301 three-axis Hall-effect sensor IC is a flexible magnetic sensor capable of measuring the applied flux density in any 1, 2, or 3 axes as well as calculating the angle in up to any two user defined planes. The A31301 comes in three standard field configurations of ±600 G, ±1400 G, or ±2000 G. Additionally, the devices are available preconfigured for SPI or I<sup>2</sup>C. Magnetic temperature coefficient is customer-programmable, with a factory default trim for neodymium magnets.

The A31301 supports two different digital interfaces for ease of use: four-wire SPI or I<sup>2</sup>C. For high-speed applications, the SPI can operate up to 10 MHz, and the I<sup>2</sup>C interface can operate up to 1 MHz. The I<sup>2</sup>C address can be set by external resistors (16 unique addresses) or can be programmed into EEPROM via I<sup>2</sup>C (127 unique addresses), allowing for multiple devices on the same bus.

Power management of the A31301 is highly configurable, allowing for system-level optimization of supply current and performance. Low-leakage sleep current makes the A31301 well-suited for portable, battery-operated applications.

The A31301 is supplied in a 3 mm × 3 mm × 0.8 mm, 10-contact DFN package (suffix “EJ”). This small footprint package is lead (Pb) free, with 100 % matte-tin leadframe plating.

### PACKAGE: 10-Contact DFN (EJ)

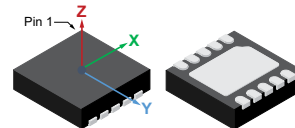

Not to scale

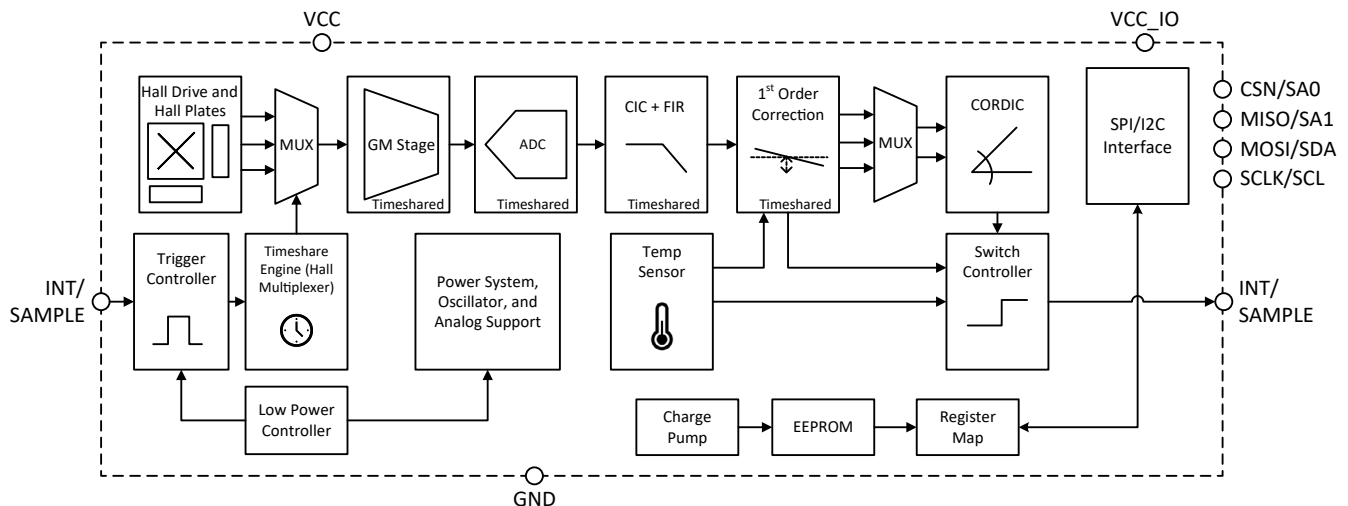

Figure 1: Functional Block Diagram

# A31301

## 3D Linear Hall-Effect Sensor with SPI, I<sup>2</sup>C Interfaces, and Advanced Low-Power Management

### SELECTION GUIDE

Part Number	Default Interface	Supported Field Range (G) (Typ.) <sup>[1]</sup>	Packing <sup>[2]</sup>
A31301EEJASR-XYZ-IC-06	I <sup>2</sup> C	±600	6000 pieces per 13-inch reel
A31301EEJASR-XYZ-IC-14		±1400	
A31301EEJASR-XYZ-IC-20		±2000	
A31301EEJASR-XYZ-SI-06	SPI	±600	
A31301EEJASR-XYZ-SI-14		±1400	
A31301EEJASR-XYZ-SI-20		±2000	

<sup>[1]</sup> 1 gauss (G) = 0.1 millitesla (mT).

<sup>[2]</sup> Contact Allegro™ for alternate packing options.

### NAMING SPECIFICATION

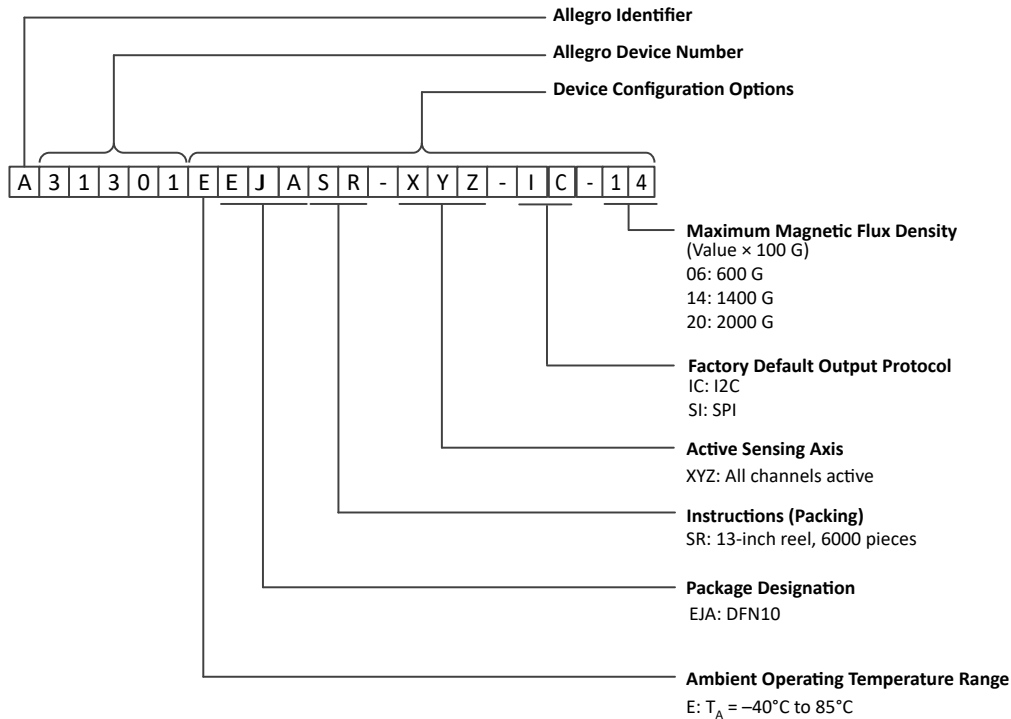

### ABSOLUTE MAXIMUM RATINGS

Characteristic	Symbol	Notes	Rating	Unit
Forward Supply Voltage	$V_{CC}$		3.6	V
Reverse Supply Voltage	$V_{RCC}$		-0.5	V
Forward IO Supply Voltage	$V_{CC(IO)}$		$V_{CC}$	V
Reverse IO Supply Voltage	$V_{RCC(IO)}$		-0.5	V
All Other Pins Forward Voltage	$V_{IN}$	Digital IO Pins, SDA, SCL, SA0, SA1, SCLK, MISO, MOSI, CSN	$V_{CC(IO)}$	V
All Other Pins Reverse Voltage	$V_R$		-0.5	V
Operating Ambient Temperature	$T_A$	Range E	-40 to 85	°C
Maximum Junction Temperature	$T_{J(MAX)}$		165	°C
Storage Temperature <sup>[1]</sup>	$T_{stg}$		-65 to 170	°C
EEPROM Write Count <sup>[2]</sup>	–	Number of times EEPROM can be written	100	writes

<sup>[1]</sup> Stresses beyond the absolute maximum ratings may result in permanent device damage. Exposure to absolute maximum rating conditions for extended periods of time may affect device reliability.

<sup>[2]</sup> EEPROM writes are not supported at temperatures above 85°C.

### THERMAL CHARACTERISTICS <sup>[1]</sup>

Characteristic	Symbol	Test Conditions	Value	Unit
Package Thermal Resistance <sup>[2]</sup>	$R_{\theta JA}$	Measured on 2-layer board with copper limited to the solder pads and 0.88 in. <sup>2</sup> of copper on each side	65	°C/W

<sup>[1]</sup> Thermal characteristics may require derating at maximum conditions. See application section for more information.

<sup>[2]</sup> Additional thermal information available on the Allegro website.

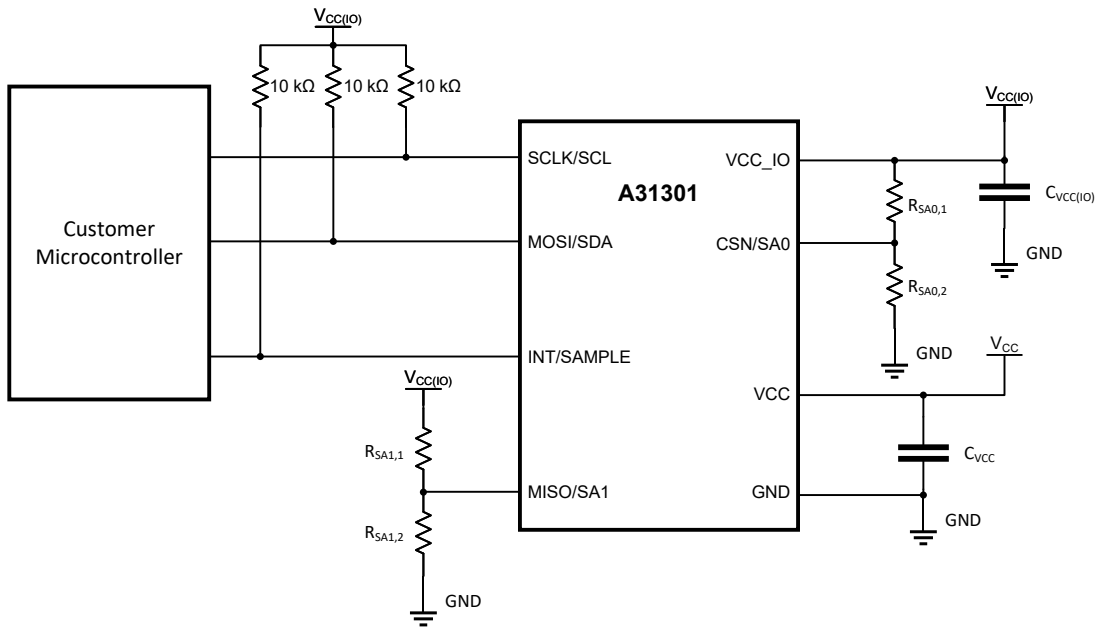

(a) I<sup>2</sup>C Interface

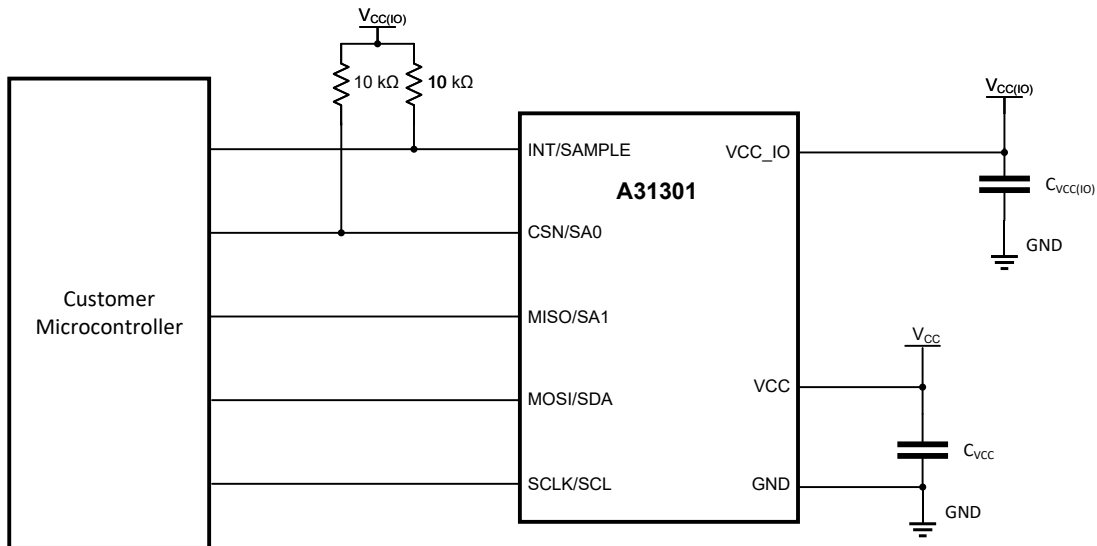

(b) SPI Interface

Figure 2: Typical Application Circuits

### PINOUT DIAGRAM AND TERMINAL LIST

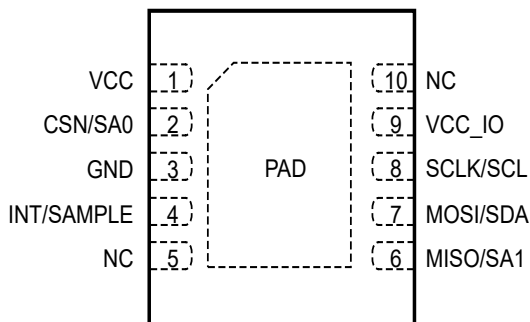

**Package EJ, 10-Contact DFN Pinout Diagram**

#### Terminal List Table

Number	Name	Function
1	VCC	Power supply input. Bypass VCC to GND with a 0.1 $\mu$ F capacitor.
2	CSN/SA0	CSN: SPI chip select, active low. SA0: I <sup>2</sup> C address Select 0. Connect a resistive divider to SA0 to select the device address. See Application Information section on addressing for more information.
3	GND	Ground signal terminal.
4	INT/ SAMPLE	INT: Interrupt output. See Application Information section on interrupt function for more information. SAMPLE: Sample trigger Input. See Application Information section on sample function for more information. When INT/SAMPLE features are unused and disabled, recommend to tie pin to GND.
5	NC	Not internally connected. Connect to GND.
6	MISO/SA1	MISO: SPI output (controller-in peripheral-out). SA1: I <sup>2</sup> C address select 1. Connect a resistive divider to SA1 to select the device's address. See Application Information section on addressing for more information.
7	MOSI/SDA	MOSI: SPI input (controller-out peripheral-in). SDA: I <sup>2</sup> C serial data input/output. Open-drain.
8	SCLK/SCL	SCLK: SPI serial clock input. SCL: I <sup>2</sup> C serial clock input.
9	VCC_IO	Voltage reference for digital IO pins.
10	NC	Not internally connected. Connect to GND.
–	PAD	Exposed pad. Not connected internally. Connect to GND

**ELECTRICAL CHARACTERISTICS:** Valid at  $T_A = 25^\circ\text{C}$ ,  $V_{CC} = V_{CC\_IO} = 3.0\text{ V}$ ,  $C_{VCC} = 0.1\ \mu\text{F}$ , unless otherwise specified

Characteristics	Symbol	Test Conditions	Min.	Typ.	Max.	Unit
<b>ELECTRICAL CHARACTERISTICS</b>						
Supply Voltage	$V_{CC}$	Normal operation	2.65	3.0	3.6	V
		EEPROM programming [1]	2.8	–	3.5	V
Supply Voltage Ramp [2]	$V_{CC\_RAMP}$	Ramp rate from 0 to 3.3 V	0.1	–	10000	$\mu\text{s}$
Digital Supply Voltage	$V_{CC\_IO}$	$V_{CC\_IO} \leq V_{CC}$	1.7	–	$V_{CC}$	V
Supply Current [3]	$I_{CC(\text{ACTIVE})}$	Active state	–	3.8	4.75	mA
	$I_{CC(\text{INACTIVE})}$	OP_MODE = 5, 6; inactive state	–	25	–	$\mu\text{A}$
	$I_{CC(\text{LPDCM})}$	Average current in LPDCM; OP_MODE = 6, SLEEP_CNT = 7, CIC_BW_SEL_LPM = 6	–	25	–	$\mu\text{A}$
		Average current in LPDCM; OP_MODE = 6, SLEEP_CNT = 0, CIC_BW_SEL_LPM = 0	–	2	–	mA
	$I_{CC(\text{SLEEP})}$	$V_{CC} = 3.0\text{ V}$ , OP_MODE = 3, 4 [4]	–	2.5	–	$\mu\text{A}$
	$I_{CC(\text{EE})}$	$V_{CC} = V_{CC(\text{MAX})}$ , EEPROM programming occurring [2]	–	6.2	–	mA
	$I_{CC\_IO}$	Current consumption on $V_{CC\_IO}$	–	25	–	$\mu\text{A}$
Power-On Reset	$V_{POR}$	Minimum $V_{CC}$ before turn-on	–	2.51	–	V
Power-On Delay Time [5]	$t_{POD}$	$T_A = 25^\circ\text{C}$ , after $V_{CC}$ reaches $V_{CC(\text{MIN})}$ , BW Select = 0	1	–	–	ms
EEPROM Write Delay Time	$t_{EEP}$	Wait after writing to EEPROM	–	50	–	ms
Linearity Sensitivity Error	$E_{LIN}$	Through full range of $B_{IN}$	–	$\pm 1.7$	–	%
Sensitivity Temperature Coefficient [2]	$TC_{SENS}$	NdFeB magnet	–	0.12	–	% / $^\circ\text{C}$
<b>INT PIN CHARACTERISTICS</b>						
INT Output On Resistance	$R_{ON}$		–	90	–	$\Omega$
INT Input Current	$I_{INT(\text{IN})}$	$V_{IN} = 0\text{ V to }V_{CC}$	–1	0	1	$\mu\text{A}$
INT Pull Up Resistance	$R_{INT(\text{PU})}$		2.4	10	–	k $\Omega$
INT Pull Up Voltage	$V_{INT(\text{PU})}$		–	3.0	3.6	V
<b>ADDRESS PIN CHARACTERISTICS [2]</b>						
Address Value 0 Reference	$V_{ADDR0}$	SA0, SA1	–	0	0.1	$\times V_{CC\_IO}$
Address Value 1 Reference	$V_{ADDR1}$	SA0, SA1	0.23	0.33	0.43	$\times V_{CC\_IO}$
Address Value 2 Reference	$V_{ADDR2}$	SA0, SA1	0.57	0.67	0.77	$\times V_{CC\_IO}$
Address Value 3 Reference	$V_{ADDR3}$	SA0, SA1	0.9	1	–	$\times V_{CC\_IO}$
Address Pin Input Resistance	$R_{ADD(\text{IN})}$	SA0, SA1	0.8	1	1.2	M $\Omega$

[1] Parameter is tested at wafer probe only.

[2] Parameter not measured at final test. Determined by design and characterization.

[3]  $I_{CC}$  varies based on lower power duty cycle settings. See Application Information section on power modes.

[4]  $I_{CC(\text{SLEEP})}$  in OP\_MODE = 4 is during the idle window. The device draws the same current as  $I_{CC(\text{ACTIVE})}$  when a conversion is requested. Average  $I_{CC}$  in this mode is dependent on the user set sampling rate.

[5] Minimum time to delay after power on before initiating communications. The device does not respond to I<sup>2</sup>C or SPI inputs until after the power-on delay time.  $t_{POD}$  varies based on BW Select code, with code 0 being the slowest.

**I<sup>2</sup>C INTERFACE CHARACTERISTICS [1]:** Valid at T<sub>A</sub> = 25°C, V<sub>CC</sub> = V<sub>CC\_IO</sub> = 3.0 V, C<sub>BYPASS</sub> = 0.1 μF, R<sub>PU</sub> = 10 kΩ, and I<sup>2</sup>C Clock Speed (FCLK) = 400 kHz, unless otherwise specified

Characteristics	Symbol	Test Conditions	Min.	Typ.	Max.	Unit
Bus Free Time Between Stop and Start	t <sub>BF</sub>	OP_MODE = 0, 1, 2	1.3	–	–	μs
		OP_MODE = 5, 6	25	–	–	μs
Hold Time Start Condition	t <sub>STA(H)</sub>		0.6	–	–	μs
Setup Time for Repeated Start Condition	t <sub>STA(S)</sub>		0.6	–	–	μs
SCL Low Time	t <sub>LOW</sub>		1.3	–	–	μs
SCL High Time	t <sub>HIGH</sub>		0.6	–	–	μs
Data Setup Time	t <sub>DAT(S)</sub>		100	–	–	ns
Data Hold Time	t <sub>DAT(H)</sub>		0	–	900	ns
Setup Time for Stop Condition	t <sub>STO(S)</sub>		0.6	–	–	μs
Logic Input Low Level (SDA, SCL Pins)	V <sub>I(L)</sub>	I2C_THRESH_SEL = 0; 3.0 V compatible mode	–	–	0.9	V
		I2C_THRESH_SEL = 1; 1.8 V compatible mode	–	–	0.54	V
Logic Input High Level (SDA, SCL Pins)	V <sub>I(H)</sub>	I2C_THRESH_SEL = 0; 3.0 V compatible mode	2.1	–	–	V
		I2C_THRESH_SEL = 1; 1.8 V compatible mode	1.26	–	–	V
Logic Input Current	I <sub>I2C(IN)</sub>	V <sub>IN</sub> = 0 V to V <sub>CC</sub> , R <sub>PU</sub> = 2.4 kΩ	–1	0	1	μA
Output Voltage (SDA Pin)	V <sub>O(L)</sub>	I <sub>LOAD</sub> = 1.5 mA	–	–	0.36	V
Clock Frequency (SCL Pin)	f <sub>CLK</sub>		–	400	1000	kHz
Output Fall Time (SDA Pin)	t <sub>f</sub>	R <sub>PU</sub> = 2.4 kΩ, C <sub>BUS</sub> = 100 pF	–	–	250	ns
I <sup>2</sup> C Pull-Up Resistance	R <sub>I2C(PU)</sub>		2.4	10	–	kΩ
I <sup>2</sup> C Pull-Up Voltage	V <sub>I2C(PU)</sub>		1.8	3.0	3.3	V
Total Capacitive Load for SDA and SCL Buses	C <sub>BUS</sub>		–	–	100	pF

[1] I<sup>2</sup>C interface characteristics are not measured at final test. Determined by design and characterization.

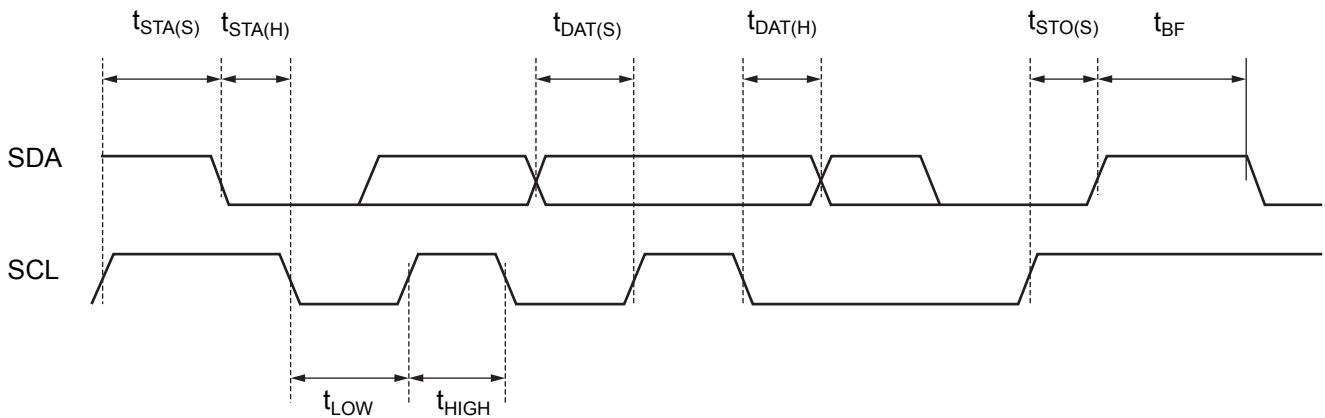

**Figure 3: I<sup>2</sup>C Interface Timing Diagram**

**SPI INTERFACE CHARACTERISTICS:** Valid at  $T_A = 25^\circ\text{C}$ ,  $C_{\text{BYPASS}} = 0.1 \mu\text{F}$ , unless otherwise noted

Characteristics	Symbol	Test Conditions	Min.	Typ.	Max.	Unit
<b>SPI INTERFACE SPECIFICATIONS</b>						
SPI Packet Size	$N_{\text{SPI}}$	Number of bits per SPI transaction, with and without CRC	16	–	20	bits
Digital Input High Voltage	$V_{\text{IH}}$	MOSI, SCLK, CSN pins	0.65	–	1	$\times V_{\text{CC\_IO}}$
Digital Input Low Voltage	$V_{\text{IL}}$	MOSI, SCLK, CSN pins	–	–	0.35	$\times V_{\text{CC\_IO}}$
SPI Output High Voltage	$V_{\text{OH}}$	MISO pins, $C_L = 10 \text{ pF}$				V
SPI Output Low Voltage	$V_{\text{OL}}$	MISO pins, $C_L = 10 \text{ pF}$				V
SPI Clock Frequency	$f_{\text{SPI}}$		0.1	–	10	MHz
SPI Duty Cycle	$D_{\text{ISCLK}}$	$\text{SPICK}_{\text{DC}}$	40	–	60	%
SPI Frame Rate	$t_{\text{SPI}}$		5.8	–	588	kHz
Chip Select to First SCK Edge	$t_{\text{CS}}$	Time from CSN going low to SCLK falling edge	50	–	–	ns
Chip Select Idle Time	$t_{\text{CS\_IDLE}}$	OP_MODE = 0, 1, 2	425	–	–	ns
		OP_MODE = 5, 6	37.5	–	–	$\mu\text{s}$
Data Out Valid Time	$t_{\text{DAV}}$	Data output valid after SCLK falling edge	–	30	–	ns
MOSI Setup Time	$t_{\text{SU}}$	Input setup time before SCLK rising edge	25	–	–	ns
MOSI Hold Time	$t_{\text{HD}}$	Input hold time after SCLK rising edge	50	–	–	ns
MISO Off Time	$t_{\text{off}}$	Time from CSN going high to MISO tri-stating	–	45	–	ns
SCLK to CS Hold Time	$t_{\text{CHD}}$	Hold SCLK high time before CS rising edge	5	–	–	ns
Load Capacitance	$C_L$	Loading on digital output (MISO) pin, $V_{\text{CC\_IO}} = 3.3 \text{ V}$	–	–	10	pF

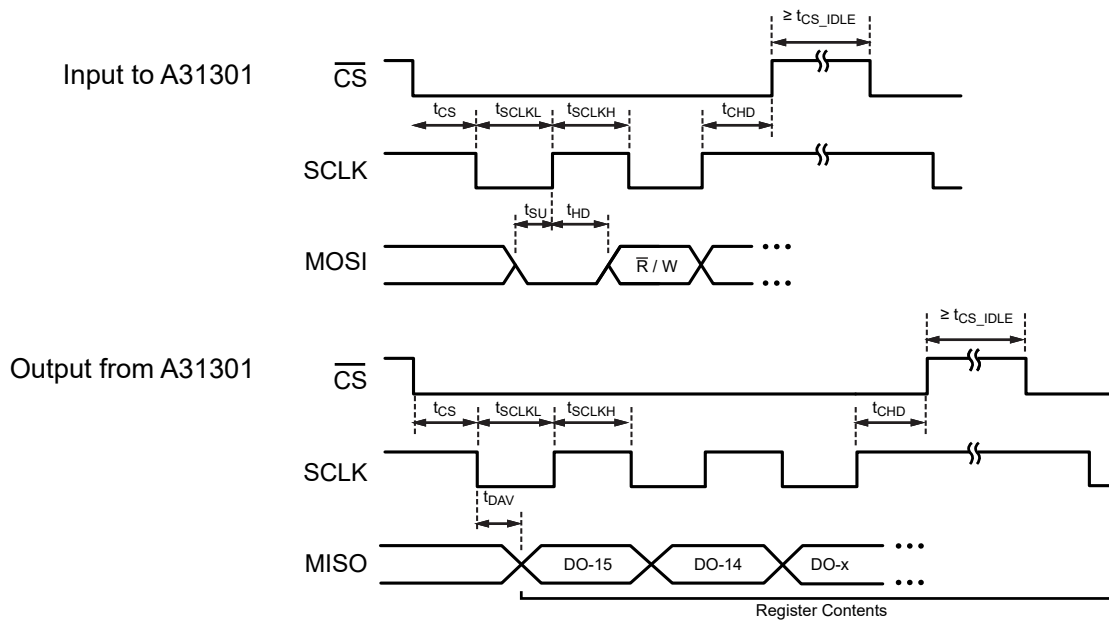

**Figure 4: SPI Interface Timings: (upper) input and (lower) register output**

**A31301EEJA-XYZ-06 PERFORMANCE CHARACTERISTICS:** Valid at  $T_A = 25^\circ\text{C}$ ,  $V_{CC} = 3.0\text{ V}$ , and  $C_{BYPASS} = 0.1\ \mu\text{F}$ , unless otherwise specified

Characteristics	Symbol	Test Conditions	Min.	Typ.	Max.	Unit [1]
<b>NOMINAL PERFORMANCE</b>						
Optimized Sensing Range	$B_{IN}$		–	±600	–	G
Sensitivity	SENS		–	26.8	–	LSB/G
Zero-Field Offset Code	QVO	$B_{IN} = 0\text{ G}$	–	0	–	LSB
<b>ACCURACY PERFORMANCE</b>						
Offset Error X/Y Axes	$E_{OFF(XY)}$	$B_{IN} = 0\text{ G}$	–6	–	6	G
Offset Error Z Axis	$E_{OFF(Z)}$	$B_{IN} = 0\text{ G}$	–6	–	6	G
Sensitivity Error X/Y Axes	$E_{SENS(XY)}$	$B_{IN} = B_{IN(MAX)}$	–2.5	–	2.5	%
Sensitivity Error Z Axis	$E_{SENS(Z)}$	$B_{IN} = B_{IN(MAX)}$	–3.5	–	3.5	%
Sensitivity Mismatch Error X Axis to Y Axis [5]	$E_{MATCH(XY)}$	$B_{IN} = B_{IN(MAX)}$	–	±1.1	–	%
Sensitivity Mismatch Error X/Y Axes to Z Axis [5]	$E_{MATCH(XYZ)}$	$B_{IN} = B_{IN(MAX)}$	–	±3	–	%
Magnetic Temperature Coefficient Sensitivity [2]	$SENS_{TC}$	$25^\circ\text{C} < T_A < 85^\circ\text{C}$	0.08	0.12	0.16	% / °C
		$-40^\circ\text{C} < T_A < 25^\circ\text{C}$	0.04	0.12	0.2	% / °C
Angle Error X-Z, Y-Z Plane [2]	$E_{ANG(XZ)}$	$B_{IN} \geq 500\text{ G}$	–	±2.0	–	°
Angle Error X-Y Plane [2]	$E_{ANG(XY)}$	$B_{IN} \geq 500\text{ G}$	–	±1.5	–	°
<b>NOISE CHARACTERISTICS</b>						
RMS Noise X/Y Channels [2][3]	$N_{RMS(XY)}$	BW Select = 0	–	0.100	–	G
		BW Select = 6	–	0.800	–	G
RMS Noise Z Channel [2][3]	$N_{RMS(Z)}$	BW Select = 0	–	0.052	–	G
		BW Select = 6	–	0.414	–	G
RMS Angle Noise [2][3]	$N_{RMS(\theta XY)}$	BW Select = 0, $B_{IN} = 300\text{ G}$	–	0.020	–	°
<b>LIFETIME DRIFT CHARACTERISTICS</b>						
Offset Error Lifetime Drift [4]	$E_{OFF\_DRIFT}$		–2	–	2	G
Sensitivity Error Lifetime Drift [4]	$E_{SENS\_DRIFT}$		–3.5	–	3.5	%

[1] 1 G (gauss) = 0.1 mT (millitesla)

[2] Parameter not measured at final test. Determined by design and characterization.

[3] RMS noise equivalent to 1 standard deviation (sigma) distribution.

[4] Lifetime drift characteristics are based on worst-case error or drift seen during device qualification.

[5] Typical values are ±3 sigma values.

**A31301EEJA-XYZ-14 PERFORMANCE CHARACTERISTICS:** Valid at  $T_A = 25^\circ\text{C}$ ,  $V_{CC} = 3.0\text{ V}$ , and  $C_{BYPASS} = 0.1\ \mu\text{F}$ , unless otherwise specified

Characteristics	Symbol	Test Conditions	Min.	Typ.	Max.	Unit [1]
<b>NOMINAL PERFORMANCE</b>						
Optimized Sensing Range	$B_{IN}$		–	±1400	–	G
Sensitivity	SENS		–	11.47	–	LSB/G
Zero-Field Offset Code	QVO	$B_{IN} = 0\text{ G}$	–	0	–	LSB
<b>ACCURACY PERFORMANCE</b>						
Offset Error X/Y Axes	$E_{OFF(XY)}$	$B_{IN} = 0\text{ G}$	–6	–	6	G
Offset Error Z Axis	$E_{OFF(Z)}$	$B_{IN} = 0\text{ G}$	–6	–	6	G
Sensitivity Error X/Y Axes	$E_{SENS(XY)}$	$B_{IN} = B_{IN(MAX)}$	–2.5	–	2.5	%
Sensitivity Error Z Axis	$E_{SENS(Z)}$	$B_{IN} = B_{IN(MAX)}$	–3.5	–	3.5	%
Sensitivity Mismatch Error X Axis to Y Axis [5]	$E_{MATCH(XY)}$	$B_{IN} = B_{IN(MAX)}$	–	±1.1	–	%
Sensitivity Mismatch Error X/Y Axes to Z Axis [5]	$E_{MATCH(XYZ)}$	$B_{IN} = B_{IN(MAX)}$	–	±3	–	%
Magnetic Temperature Coefficient Sensitivity [2]	$SENS_{TC}$	$25^\circ\text{C} < T_A < 85^\circ\text{C}$	0.08	0.12	0.16	% / °C
		$-40^\circ\text{C} < T_A < 25^\circ\text{C}$	0.04	0.12	0.2	% / °C
Angle Error X-Z, Y-Z Plane [2]	$E_{ANG(XZ)}$	$B_{IN} \geq 500\text{ G}$	–	±2.0	–	°
Angle Error X-Y Plane [2]	$E_{ANG(XY)}$	$B_{IN} \geq 500\text{ G}$	–	±1.5	–	°
<b>NOISE CHARACTERISTICS</b>						
RMS Noise X/Y Channels [2] [3]	$N_{RMS(XY)}$	BW Select = 0	–	0.13	–	G
		BW Select = 6	–	1.03	–	G
RMS Noise Z Channel [2] [3]	$N_{RMS(Z)}$	BW Select = 0	–	0.10	–	G
		BW Select = 6	–	0.83	–	G
RMS Angle Noise [2] [3]	$N_{RMS(\theta XY)}$	BW Select = 0, $B_{IN} = 700\text{ G}$	–	0.01	–	°
<b>LIFETIME DRIFT CHARACTERISTICS</b>						
Offset Error Lifetime Drift [4]	$E_{OFF\_DRIFT}$		–2	–	2	G
Sensitivity Error Lifetime Drift [4]	$E_{SENS\_DRIFT}$		–3.5	–	3.5	%

[1] 1 G (gauss) = 0.1 mT (millitesla)

[2] Parameter not measured at final test. Determined by design and characterization.

[3] RMS noise equivalent to 1 standard deviation (sigma) distribution.

[4] Lifetime drift characteristics are based on worst-case error or drift seen during device qualification.

[5] Typical values are ±3 sigma values.

**A31301EEJA-XYZ-20 PERFORMANCE CHARACTERISTICS:** Valid at  $T_A = 25^\circ\text{C}$ ,  $V_{CC} = 3.0\text{ V}$ , and  $C_{BYPASS} = 0.1\ \mu\text{F}$ , unless otherwise specified

Characteristics	Symbol	Test Conditions	Min.	Typ.	Max.	Unit [1]
<b>NOMINAL PERFORMANCE</b>						
Optimized Sensing Range	$B_{IN}$		–	±2000	–	G
Sensitivity	SENS		–	8.03	–	LSB/G
Zero-Field Offset Code	QVO	$B_{IN} = 0\text{ G}$	–	0	–	LSB
<b>ACCURACY PERFORMANCE</b>						
Offset Error X/Y Axes	$E_{OFF(XY)}$	$B_{IN} = 0\text{ G}$	–6	–	6	G
Offset Error Z Axis	$E_{OFF(Z)}$	$B_{IN} = 0\text{ G}$	–6	–	6	G
Sensitivity Error X/Y Axes	$E_{SENS(XY)}$	$B_{IN} = B_{IN(MAX)}$	–2.5	–	2.5	%
Sensitivity Error Z Axis	$E_{SENS(Z)}$	$B_{IN} = B_{IN(MAX)}$	–3.5	–	3.5	%
Sensitivity Mismatch Error X Axis to Y Axis [5]	$E_{MATCH(XY)}$	$B_{IN} = B_{IN(MAX)}$	–	±1.1	–	%
Sensitivity Mismatch Error X/Y Axes to Z Axis [5]	$E_{MATCH(XYZ)}$	$B_{IN} = B_{IN(MAX)}$	–	±3	–	%
Magnetic Temperature Coefficient Sensitivity [2]	$SENS_{TC}$	$25^\circ\text{C} < T_A < 85^\circ\text{C}$	0.08	0.12	0.16	%/°C
		$-40^\circ\text{C} < T_A < 25^\circ\text{C}$	0.04	0.12	0.2	%/°C
Angle Error X-Z, Y-Z Plane [2]	$E_{ANG(XZ)}$	$B_{IN} \geq 500\text{ G}$	–	±2.0	–	°
Angle Error X-Y Plane [2]	$E_{ANG(XY)}$	$B_{IN} \geq 500\text{ G}$	–	±1.5	–	°
<b>NOISE CHARACTERISTICS</b>						
RMS Noise X/Y Channels [2] [3]	$N_{RMS(XY)}$	BW Select = 0	–	0.14	–	G
		BW Select = 6	–	1.12	–	G
RMS Noise Z Channel [2] [3]	$N_{RMS(Z)}$	BW Select = 0	–	0.16	–	G
		BW Select = 6	–	1.24	–	G
RMS Angle Noise [2] [3]	$N_{RMS(\theta XY)}$	BW Select = 0, $B_{IN} = 1000\text{ G}$	–	0.01	–	°
<b>LIFETIME DRIFT CHARACTERISTICS</b>						
Offset Error Lifetime Drift [4]	$E_{OFF\_DRIFT}$		–2	–	2	G
Sensitivity Error Lifetime Drift [4]	$E_{SENS\_DRIFT}$		–3.5	–	3.5	%

[1] 1 G (gauss) = 0.1 mT (millitesla)

[2] Parameter not measured at final test. Determined by design and characterization.

[3] RMS noise equivalent to 1 standard deviation (sigma) distribution.

[4] Lifetime drift characteristics are based on worst-case error or drift seen during device qualification.

[5] Typical values are ±3 sigma values.

### APPLICATION INFORMATION

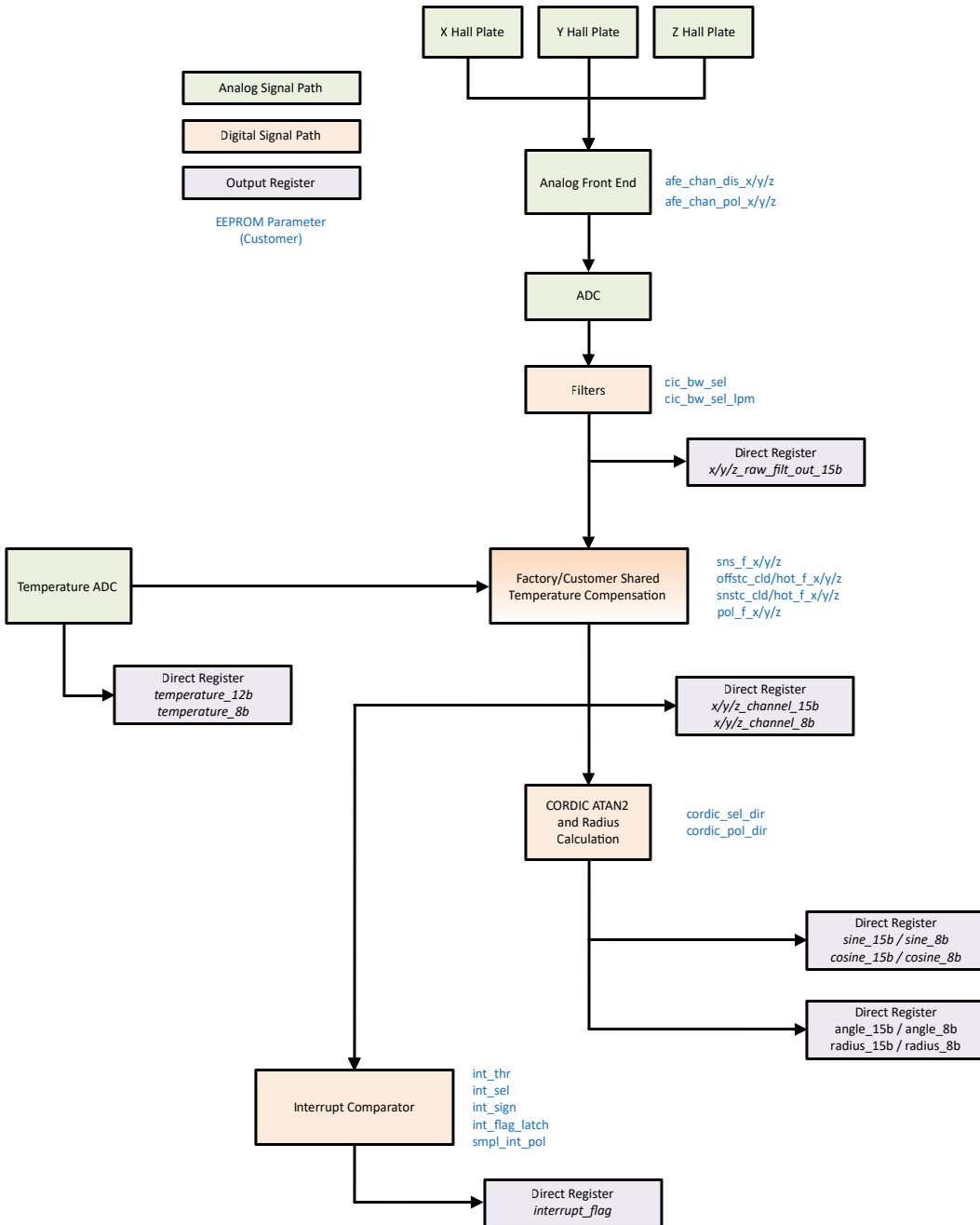

Figure 5: A31301 Signal Path

### Magnetic Sensor(s) Output

The A31301 provides 8-bit and 15-bit digital output value options that are proportional to the magnetic field applied normally to any of the Hall elements as the X, Y, and Z channels. Each channel is factory-trimmed for sensitivity and offset accuracy at room temperature as well as with a target temperature compensation. The room temperature sensitivity and sensitivity and offset temperature compensation parameters are accessible by the customer for additional adjustment in application. This allows the A31301 to be used in both rotary and linear position applications in any mounting orientation relative to the sensing magnet and to provide high accuracy and matching as the device and magnetic system changes over temperature. Starting with the raw filter output, which can be read in registers X/Y/Z\_RAW\_FILT\_OUT\_15B, the single dimension magnetic data is corrected through the following steps:

$$A = X/Y/Z\_RAW\_FILT\_OUT\_15B + \text{Factory Offset Correction}$$

$$B = A \times SENS\_F\_X/_Y/_Z \times -1^{(POL\_F\_X/Y/Z)}$$

$$C = B + (OFFSTC\_HOT/CLD\_F\_X/Y/Z \times \text{Temperature})$$

$$X/Y/Z\_CHANNEL\_15B = C \times (SENSTC\_HOT/CLD\_F\_X/Y/Z \times \text{Temperature})$$

The A31301 features an internal ATAN calculation on any two of the three user-selectable axes, X, Y, or Z. One of the channels is designated the sine channel, and the other designated as the cosine channel. This is done with the indirect extended space EEPROM parameter CORDIC\_SEL or the volatile direct primary space parameter CORDIC\_SEL\_DIR.

**Table 1: CORDIC\_SEL Decode**

CORDIC_SEL	COSINE Channel	SINE Channel
0	X	Y
1	X	Z
2	Y	Z
3	Y	X
4	Z	X
5	Z	Y
6	X	Y
7	X	Y

The sine channel is stored in the direct primary space registers SIN\_8B and SINE\_15B while the cosine channel is stored in the direct primary space registers COS\_8B and COSINE\_15B.

The angle between the magnetic vectors selected by the sine and cosine channels is taken as the ATAN, following the equation:

$$\theta = \tan^{-1} \frac{\sin \theta}{\cos \theta}$$

This angle can have an inverted polarity, decreasing code output with increasing input angle using the CORDIC\_POL parameter.

$$Angle_{out} = \begin{cases} Angle_{in} & \text{for } CORDIC\_POL = 0 \\ 360^\circ - Angle_{in} & \text{for } CORDIC\_POL = 1 \end{cases}$$

The polarity can also be adjusted after power on in the volatile direct primary space register CORDIC\_POL\_DIR. The angle output is stored in the direct space registers ANGLE\_8B and ANGLE\_15B.

While calculating the angle, the digital processing also tracks the magnitude of the angle vector from the sine and cosine channels as the radius squared following the equation:

$$radius^2 = cosine^2 + sine^2$$

This radius squared value is stored in the direct space registers RADIUS\_SQ\_8B and RADIUS\_15B.

### Temperature Sensor Output

The A31301 provides a 12-bit digital output that is proportional to the junction temperature of the IC. Temperature can be calculated by:

$$Temp [^\circ C] = \frac{TEMPERATURE\_12B}{8.052} + 25$$

### Special Function Pin; INT/SAMPLE

The A31301 has a special function pin, INT/SAMPLE that can be set as either an output as an interrupt pin, or an input as a sample request pin depending on the configured power mode.

#### SAMPLE MODE

While in sample mode, the special function pin acts as an input and can trigger a request to start a new conversation of the magnetic signal. This allows the host/user to synchronize the acquisition of the magnetic data. The device is in a standby mode (no data acquisition) until either the INT/SAMPLE pin is brought high or the direct register START\_SAMPLE bit is set by the host. When this pin transitions active (defined by SAMPLE\_INT\_POLARITY\_DIR) or the START\_SAMPLE bit is set, a sample is triggered. The front end acquires data and the output registers is updated with the new data, the output registers are set, the STATUS\_READY flag is asserted, and the device returns to standby.

This mode is particularly useful for signal processing applications which are sensitive to time/speed considerations (such as feedback and control applications) where deterministic sampling is critical for loop stability.

Subsequent sample signals are ignored if the device is in the process of acquiring new data from an initial sample request. Data registers are updated only once per INT/SAMPLE pin or START\_SAMPLE write trigger. If DATA\_LATCH = 1, the STATUS\_READY bit must be cleared by the host writing a one to the bit once the reading of the stored data has been completed, in order to allow a new acquisition to happen.

### INTERRUPT MODE

When the pin is in interrupt mode, the special function pin is an output and is used to indicate when a certain internal threshold has been passed. The threshold of interest is set by the direct space INTERRUPT\_SEL\_DIR register or the indirect space INT\_SEL parameter and is compared to the programmed threshold in INTERRUPT\_THR\_MSB/LSB\_DIR in the direct space, loaded from INT\_THR in the indirect space. When the selected threshold condition is met, the interrupt flag is set in the direct space register INTERRUPT\_FLAG and through the INT/SAMPLE pin. The INTERRUPT\_FLAG direct space bit always remains asserted once set and must be cleared after the interrupt condition is removed by writing to 1. If the parameter INTERRUPT\_FLAG\_LATCH\_DIR is set, the INT pin status also is latched until the INTERRUPT\_FLAG bit is written to a 1. In low-power mode, the flag takes 20  $\mu$ s to clear after the write.

**Table 2: Interrupt Selection Options, THR set by INTERRUPT\_THR\_MSB/LSB\_DIR in the direct space**

INTERRUPT_SEL_DIR/INT_SEL	Condition (INTERRUPT_SIGN_DIR = 0)	Threshold Register	Description
0	THR > X	SIGNED	Threshold register is compared to the trimmed X output
1	THR > Y	SIGNED	Threshold register is compared to the trimmed Y output
2	THR > Z	SIGNED	Threshold register is compared to the trimmed Z output
3	THR > ABS(X)	UNSIGNED	Threshold register is compared to the absolute value of the trimmed X output
4	THR > ABS(Y)	UNSIGNED	Threshold register is compared to the absolute value of the trimmed Y output
5	THR > ABS(Z)	UNSIGNED	Threshold register is compared to the absolute value of the trimmed Z output
6	THR > TEMP	SIGNED	Threshold register is compared to the temperature output
7	THR > ANGLE	UNSIGNED	Threshold register is compared to the angle output
8	THR > RADIUS	UNSIGNED	Threshold register is compared to the radius output
9	THR == New Sample	N/A	No comparison, pin provides one 10 $\mu$ s pulse that occurs when data is valid

### Operation Modes

Power management on the A31301 is user-selectable and highly configurable, allowing for system-level optimization of current consumption and performance. The A31301 supports three different power modes: active mode, sleep mode, and low-power duty cycle mode (LPDCM), each with various subconfigurations using the special function pin INT/SAMPLE. The operating mode of the A31301 is determined by the value in OP\_MODE, Direct space address 0x32:0x33, bits 3:1, described in Table 3.

#### ACTIVE MODE

In active mode, the A31301 continuously updates the channel and angle outputs at an interval defined by the bandwidth selection. This mode requires the most power but provides output register updates at the highest frequency. In addition to the standard output of active mode, the OP\_MODE register can be configured to set the device in active mode with the interrupt output enabled.

#### SLEEP MODE

In sleep mode, the A31301 enters a near powered-off state where it consumes the minimum amount of current. In this mode, the device still responds to I<sup>2</sup>C or SPI commands, but does not update magnetic or temperature data. In OP\_MODE = 4, sleep mode with sample wake, the device operates similarly as in full sleep mode but also monitors the INT/SAMPLE pin or START\_SAMPLE bit for a trigger to start a conversion. This allows the host to set a conversion frequency to best balance power and response time in their system. Sleep mode is valuable in applications where the supply voltage cannot be disabled but minimal power consumption is required. The time it takes to exit sleep mode is equivalent to power-on delay time ( $t_{POD}$ ).

#### LOW-POWER DUTY CYCLE MODE (LPDCM)

In low-power duty cycle mode (LPDCM), the A31301 toggles between active and inactive states, reducing overall current consumption. The average I<sub>CC</sub> for the A31301 during low-power duty cycle mode varies based on the device configuration. The diagram in Figure 6 shows the profile of I<sub>CC</sub> as the A31301 toggles between active and inactive states during low-power duty cycle mode.

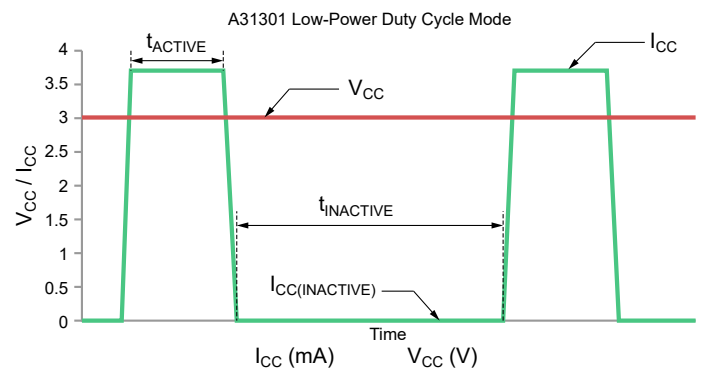

**Figure 6: I<sub>CC</sub> in Low-Power Duty Cycle Mode**

The inactive time is determined by the value set in SLEEP\_CNT Address 0x32:0x33, bits 6:4. The A31301 offers eight discrete time frames, explained in Table 4.

**Table 3: OP\_MODE Control**

Address	Bits	Value	Operating Mode	INT/SAMPLE Pin Function
Direct: 0x32:0x33	3:1	0	Active Mode	None
		1	Active Mode – Interrupt	Interrupt Output
		2	Active Mode – Sample	Sample Input
		3	Sleep Mode	None
		4	Sleep Mode with Sample Wake	Sample/Wake Input
		5	Low Power Duty Cycle Mode (LPDCM) With Interrupt	Interrupt Output
		6	Low Power Duty Cycle Mode (LPDCM)	None
		7	Active Mode	None

**Table 4: SLEEP\_CNT Decode; LPDCM Inactive Time ( $t_{INACTIVE}$ )**

Address	Bits	Value	$t_{INACTIVE}$ (typ) (ms)
Direct: 0x32:0x33	6:4	0	0.68
		1	1.36
		2	6.82
		3	13.64
		4	68.18
		5	136.36
		6	681.82
		7	1363.64

The active time is determined by a combination of the value in BW Select and the number of magnetic sensing channels enabled.

### Bandwidth Selection

The A31301 has two parameters to control the device Bandwidth and update rate in active mode and low power mode. CIC\_BW\_SEL, indirect address 0x14, bits 2:0, controls filtering modes on the A31301 for the X, Y, and Z magnetic channels in active mode while CIC\_BW\_SEL\_LPM in indirect address 0x14 bits 5:3 controls the filtering modes of the channels in low power mode

duty cycle mode. This setting impacts the resolution of sampled magnetic data, device update rate, and overall bandwidth.

A lower value for CIC\_BW\_SEL/LPM offers increased measurement resolution with a longer measurement duration. A higher value for CIC\_BW\_SEL/LPM offers faster measurement time at the expense of reduced resolution. This setting is valuable for controlling active time during low-power duty cycle mode or increasing response time. Typical noise versus CIC\_BW\_SEL/LPM are listed in Table 5.

Update rate (typical) versus CIC\_BW\_SEL/LPM and active channels is shown in Table 5. While the A31301 does update at high bandwidths internally, throughput may be limited by the communication protocol clocking frequency at the application level.

Magnetic sensing channels on the A31301 may be enabled independently with AFE\_CHAN\_DIS\_X, AFE\_CHAN\_DIS\_Y, and AFE\_CHAN\_DIS\_Z bits in the indirect space, or the equivalent AFE\_CHAN\_DIS\_X\_DIR, AFE\_CHAN\_DIS\_Y\_DIR, and AFE\_CHAN\_DIS\_Z\_DIR in the direct space.

Note: When updating the CIC\_BW\_SEL or CIC\_BW\_SEL\_LPM, the device must be reset for the change to correctly take effect.

**Table 5: Bandwidth Select, Filtering Modes, and Input Referred Noise (600 G Device Only)**

BW Select Value	Approximate Bandwidth (Hz)	Approximate Update Rate, 1 Channel ( $\mu$ s)	Approximate Update Rate, 2 Channel ( $\mu$ s)	Approximate Update Rate, 3 Channel ( $\mu$ s)	Z Channel RMS Noise (G)	X/Y Channel RMS Noise (G)
0	195.5	1024	6156	9234	0.052	0.100
1	391	512	3084	4626	0.073	0.141
2	782	256	1548	2322	0.103	0.200
3	1564	128	780	1170	0.146	0.283
4	3128	64	396	594	0.207	0.400
5	6256	32	204	306	0.293	0.566
6	12512	16	108	162	0.414	0.800
7	Not Supported					

### INTERFACE INFORMATION

#### I<sup>2</sup>C Interface

I<sup>2</sup>C is a synchronous, 2-wire serial communication protocol which provides a full-duplex interface between two or more devices. The bus specifies two logic signals:

1. Serial clock line (SCL) output by the controller.
2. Serial data line (SDA) output by either the controller or the peripheral.

The A31301 may only operate as a peripheral device. Therefore, it cannot initiate any transactions on the I<sup>2</sup>C bus.

#### Data Transmission and Timing Considerations

I<sup>2</sup>C communication is composed of several steps outlined in the following sequence.

1. Start Condition: Defined by a falling edge of the SDA line, initiated by the controller, while SCL is high.
2. Address Cycle: 7-bit Peripheral address, plus 1 bit to indicate write (0) or read (1), followed by an acknowledge bit.
3. Data Cycles: Reading or writing 8 bits of data, followed by an acknowledge bit. This cycle can be repeated for multiple bytes of data transfer. The first data byte on a write can be the register address. See the following sections for further information.
4. Stop Condition: Defined by a rising edge on the SDA line, while SCL is high.

Except to indicate start or stop conditions, SDA must remain stable while the clock signal is high. SDA may only change states while SCL is low. It is acceptable for a start or stop condition to occur at any time during the data transfer. The A31301 always responds to a read or write request by resetting the data transfer sequence.

The state of the read/write bit is set to 0 to indicate a write cycle and set to 1 to indicate a read cycle.

The controller monitors for an Acknowledge bit to confirm the Peripheral device (A31301) is responding to the address byte. When the A31301 decodes the 7-bit peripheral address as valid, it responds by pulling SDA low during the ninth clock cycle.

When a data write is requested by the controller, the A31301 pulls SDA low during the clock cycle following the data byte to indicate that the data has been successfully received.

After sending either an address byte or a data byte, the controller must release the SDA line before the ninth clock cycle, allowing the handshake process to occur.

#### I<sup>2</sup>C Write Cycle Overview

The write cycle to access registers on the A31301 are outlined in the sequence below.

1. Controller initiates start condition
2. Controller sends 7-bit peripheral address and the write bit (0)
3. Controller waits for ACK from A31301
4. Controller sends 8-bit register address
5. Controller waits for ACK from A31301
6. Controller sends 15:8 bits of data
7. Controller waits for ACK from A31301
8. Controller sends 7:0 bits of data
9. Controller waits for ACK from A31301
10. Controller initiates stop condition

The I<sup>2</sup>C write sequence is further illustrated in the timing diagrams below in Figure 7.

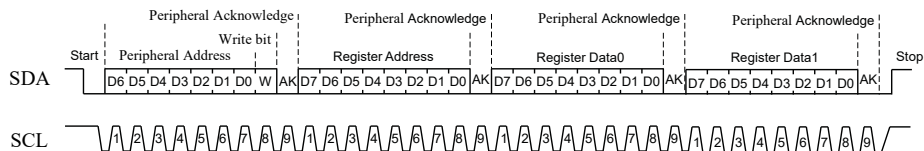

Figure 7: I<sup>2</sup>C Write Timing Diagram

### Read Cycle Overview

The read cycle to access registers on A31301 is outlined in the sequence below.

1. Controller initiates start condition
2. Controller sends 7-bit peripheral address and the write bit (0)
3. Controller waits for ACK from A31301
4. Controller sends 8-bit register address
5. Controller waits for ACK from A31301
6. Controller initiates a start condition; this time it is referred to as a restart condition
7. Controller sends 7-bit peripheral address and the read bit (1)
8. Controller waits for ACK from A31301
9. Controller receives 15:8 bits of data
10. Controller sends ACK to A31301
11. Controller receives 7:0 bits of data
12. Controller sends NACK to A31301
13. Controller initiates stop condition

The I<sup>2</sup>C read sequence is further illustrated in the timing diagrams in Figure 8.

The timing diagram in Figure 8 shows the entire contents (bits 31:0) of a single register location being transmitted. Optionally, the I<sup>2</sup>C controller may choose to replace the NACK with an ACK instead, which allows the read sequence to continue. This case results in the transfer of contents (bits 31:24) from the following register, address + 1. The controller can then continue acknowledging, issue the not-acknowledge (NACK), or stop after any byte to stop receiving data.

Note that only the initial register address is required for reads, allowing for faster data retrieval. However, this restricts data retrieval to sequential registers when using a single read command. When the controller provides a non-acknowledge bit and stop bit, the A31301 stops sending data. If nonsequential registers are to be read, separate read commands must be sent.

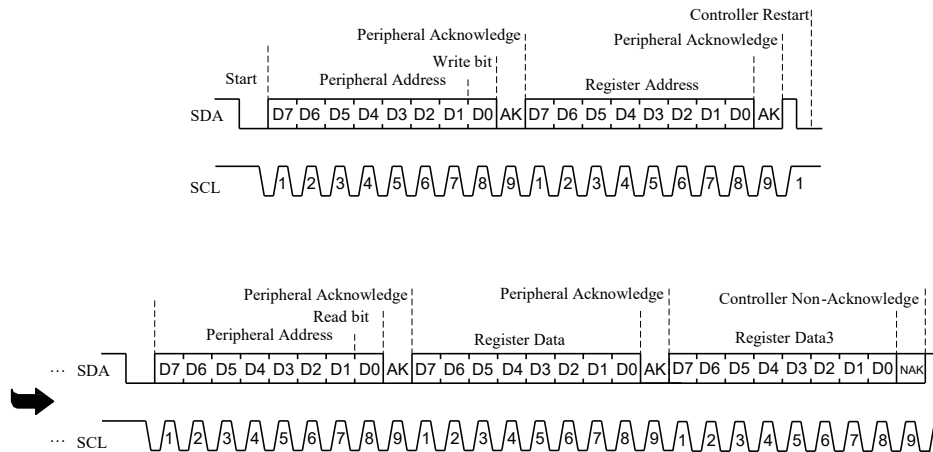

**Figure 8: I<sup>2</sup>C Read Timing Diagram**

### I<sup>2</sup>C CRC Byte

The A31301 CRC feature is enabled by setting the I2C\_CRC\_EN bit, indirect address 0x15, bit 18. When enabled, the A31301 read transaction returns one extra byte corresponding the CRC calculation of that read. The bytes of the I<sup>2</sup>C read sequence used for CRC calculation are:

1. 8-bit register address
2. The 7-bit peripheral address + read bit (1'b1)
3. The two data bytes (16 bits, MSB first)

The code is 8 bits in length and is generated using the CRC8-ATM (0x83) polynomial:

$$p(x) = x^8 + x^2 + x + 1$$

### I<sup>2</sup>C Readback Modes

The A31301 supports three different readback modes over the I<sup>2</sup>C interface, including single, continuous, and loopback modes. These modes simplify the process of repeatedly polling the A31301 for magnetic X, Y, Z, and temperature data.

#### SINGLE MODE

A single write or read command to any register—this is the default mode and is best suited for setting fields and reading static registers. If desired, this mode can be used to read data in a typical serial fashion, but fast or full loop read modes are recommended for high-speed data retrieval. After each single read is complete, the controller shall issue a NACK to complete the transaction.

#### CONTINUOUS MODE

Instead of issuing a NACK after a read request, the controller can keep issuing an ACK. When this is done, the A31301 continues transmitting data from the next address, address +2. This can be

useful for reading data from successive registers, without needing to send a read command for each register.

#### LOOPBACK MODE

Loopback mode on the A31301 is described in Table 6. The desired data to be returned serially in the loopback output register, I2C\_LOOPBACK\_16B, may be enabled by setting the appropriate bit(s) for I2C\_LOOPBACK\_CH\_SEL, direct address 0x34:0x35, bits 7:0. In this mode, the desired data is loaded into the same read address sequentially, allowing continuous polling of a single register to obtain all of the necessary data. If a NACK is sent before the loopback sequence is complete, the loop restarts upon the next request.

**Table 6: A31301 Looping Read Modes**

I2C_LOOPBACK_CH_SEL	Enabled Data in Loop
0	X_CHANNEL_15B
1	Y_CHANNEL_15B
2	Z_CHANNEL_15B
3	TEMPERATURE_12B
4	SINE_15B
5	COSINE_15B
6	RADIUS_15B
7	ANGLE_15B

### I<sup>2</sup>C Addressing

Table 7 outlines the different addresses available to the A31301. In the special case where AD0 and AD1 are both tied to VCC, the device responds to the peripheral address stored in register I2C\_SLV\_ADDR in indirect space address 0x15 (bits 16:10). From the factory, this is set to 111, with the bit following the address indicating a read or write per the I<sup>2</sup>C specification. Note: Different values for the three MSBs of the address bits (A6, A5, and A4) are available for factory programming if a conflict with other units occurs in the application design.

**Table 7: I<sup>2</sup>C Peripheral Address Decoding**

Voltage on AD1, V <sub>A1</sub> (× V <sub>CC_IO</sub> )	Voltage on AD0, V <sub>A0</sub> (× V <sub>CC_IO</sub> )	4-Bit Code from ADR1 and ADR0 Voltages				Peripheral Address Bits							Peripheral Address
		E3	E2	E1	E0	A6	A5	A4	A3	A2	A1	A0	
0	0	0	0	0	0	1	1	0	0	0	0	0	96
	0.33	0	0	0	1	1	1	0	0	0	0	1	97
	0.67	0	0	1	0	1	1	0	0	0	1	0	98
	1	0	0	1	1	1	1	0	0	0	1	1	99
0.33	0	0	1	0	0	1	1	0	0	1	0	0	100
	0.33	0	1	0	1	1	1	0	0	1	0	1	101
	0.67	0	1	1	0	1	1	0	0	1	1	0	102
	1	0	1	1	1	1	1	0	0	1	1	1	103
0.67	0	1	0	0	0	1	1	0	1	0	0	0	104
	0.33	1	0	0	1	1	1	0	1	0	0	1	105
	0.67	1	0	1	0	1	1	0	1	0	1	0	106
	1	1	0	1	1	1	1	0	1	0	1	1	107
1	0	1	1	0	0	1	1	0	1	1	0	0	108
	0.33	1	1	0	1	1	1	0	1	1	0	1	109
	0.67	1	1	1	0	1	1	0	1	1	1	0	110
	1	1	1	1	1	I2C_SLV_ADDR						Programmed to 111 at the factory	

### SPI Protocol

The A31301 provides a full-duplex 4-pin SPI interface. The sensor responds to commands received on the corresponding MOSI (controller-out peripheral-in), SCLK (serial clock), and  $\overline{CS}$  (chip select) pins, and outputs data on the MISO (controller-in peripheral-out) pin. The A31301 supports SPI mode 3 (CPOL = 1 and CPHA = 1).

### SPI Interface Timing

The SPI interface operates in pure peripheral mode, with the controller governing the SCLK, MOSI, and  $\overline{CS}$  lines. Clock frequencies up to 10 MHz are supported. Figure 4 shows timings of the write and read cycles.

### SPI Message Frame Size

An SPI transaction is a minimum of 16 bits in length. An extended 20-bit SPI packet allows 4 bits of CRC to accompany every data packet. The 4-bit CRC is automatically generated and placed on the MISO line during clocks pulses 17 through 20. The A31301 contains 16-bit primary access registers that are byte-addressable to match the SPI frame size. To access the 32-bit EEPROM, an extended access scheme is implemented, consisting of two 16-bit

registers containing the memory contents for a write, two 16-bit registers containing the memory contents for a read, and registers containing the memory locations for the write and read and execution control to begin and monitor the write/read.

### SPI Error Checking

The SPI CRC algorithm is based on the polynomial in the equation below, initialized with 0xF.

$$g(x) = x^4 + x + 1$$

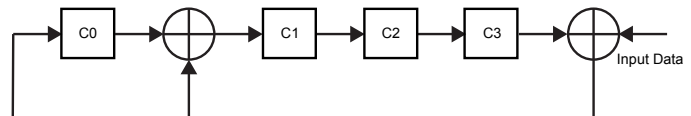

**Figure 9: SPI CRC**

For the A31301 to accept the CRC on the MOSI line, the EEPROM parameter, SPI\_CRC\_EN, must be set to 1. If the incoming SPI message is greater than 16 bits and SPI\_CRC\_EN = 0, the message is ignored.

When enabled, the 4-bit CRC is expected. If the CRC is incorrect, the SPI packet is discarded. The MISO packet on the next message is the previous read data.

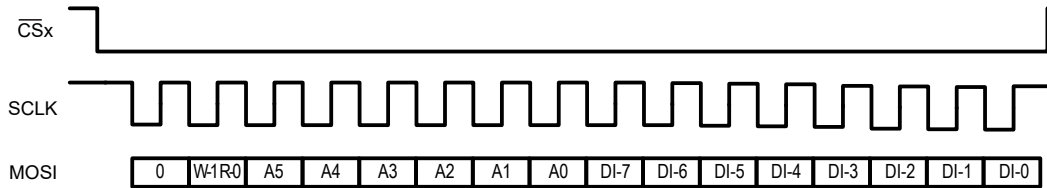

Figure 10: Sixteen-Bit SPI Message

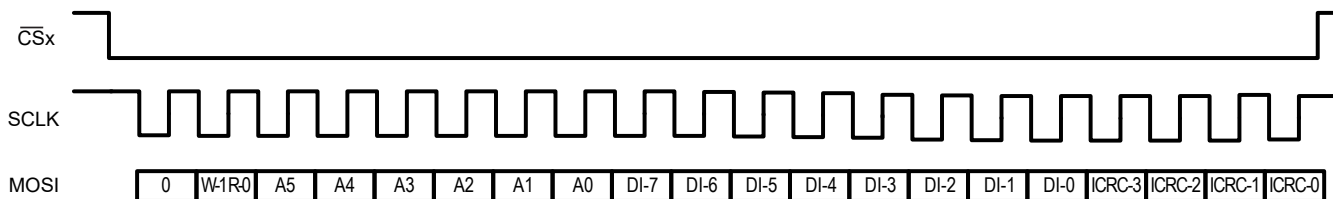

Figure 11: Twenty-Bit SPI Message

### Write Cycle Overview

Write cycles consist of 1 sync bit (low), 1 read/write bit (R/W) asserted high, 6 address bits (corresponding to the primary serial register), 8 data bits, and 4 optional CRC bits. To write a full 16-bit serial register, two write commands are required (even and odd byte addresses). MOSI bits are clocked in on the rising edge of the controller-generated SCLK signal. The complete SPI packet is latched on the rising edge of the controller-generated  $\overline{CS}$  signal.

The simultaneous MISO signal output represents the contents of the corresponding die SPI read packet, including 16 data bits and 4 optional CRC bits. The data bits correspond to the register contents selected during the previous read command. In the case where no previous read command was issued (for instance, a write command), the MISO line transmits all zeros as a return.

### Read Cycle Overview

Read cycles have two stages: a read command, selecting a serial register address, followed by another SPI command; it is during this second SPI command that data, from the selected register, is transmitted from the part to the host. Both commands consist of a 1-bit sync (low), a 1-bit R/W asserted low for a read,

6 address bits identifying the target register, and 8 data bits (these are immaterial because no data is being written), followed by 4 optional CRC bits.

In the first stage, as with the write command, read command MOSI bits are clocked-in on the rising edge of the controller generated SCLK signal, and data are latched on the rising edge of the  $\overline{CS}$  signal. During the first read stage, the simultaneous MISO signal output is either the contents of the SPI read data from a previous read command cycle, or the contents of the angle register, if the previous command was a write.

In the second stage, the read command continues on the next falling edge of the controller-generated  $\overline{CS}$  signal. The MISO bits are the contents of the register selected during the first stage, read 16 bits at a time. The MISO bits transmit on the falling edges of the SCLK signal, such that the controller can sample them on the SCLK rising edges.

Because an SPI read command can transmit 16 data bits at one time, and the primary serial registers are built from one even and one odd byte, the entire 16-bit contents of one serial register may be transmitted with one SPI frame.

Figure 12 shows examples of both an SPI write and an SPI read request, using a 16-bit SPI message frame.

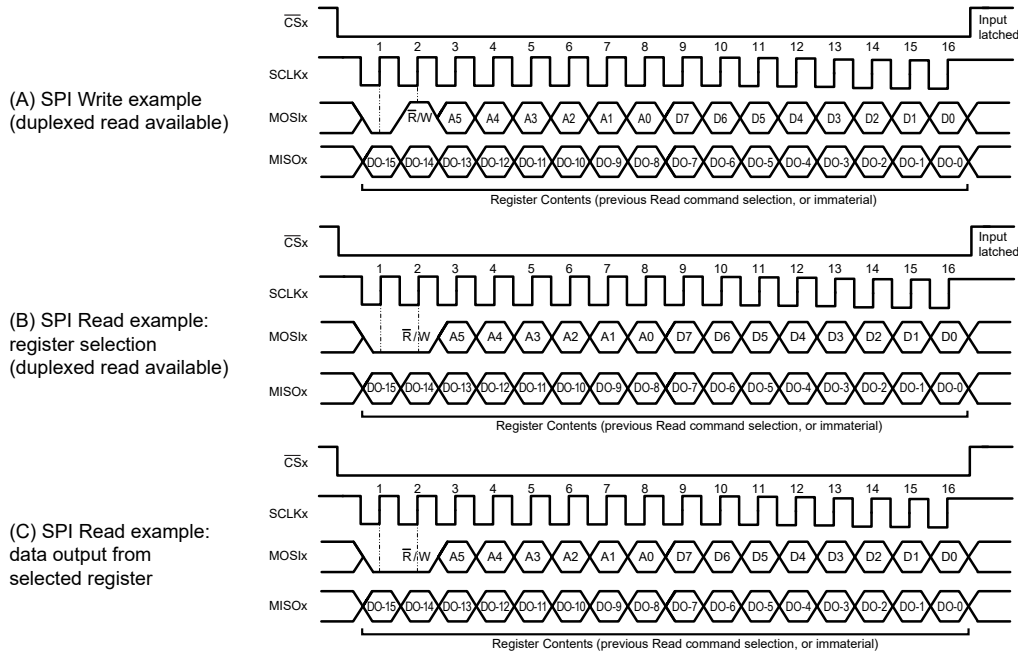

**Figure 12: SPI Read and Write Pulse Sequences**

### EEPROM Margin Checking

The A31301 contains a test mode known as EEPROM margining to check the logic levels of the EEPROM bit cells. Due to non-idealities in transistors, current slowly leaks into or out of EEPROM cells and can, over time, cause small changes in the stored voltage level. Variances in voltage levels of the charge pump can result in a variety of stored EEPROM cell voltages when programming. If this value is marginally close to the threshold, the small drift over lifetime can cause this value to move across the threshold. This results in a corrupted EEPROM value. Because this drift happens slowly over time, if there is an issue, it may not appear for years. For this reason, it is important to perform margin testing (margining) to verify the internal voltage levels of EEPROM cells after programming and ensure there will be no issue in the future.

This test should be run after writing to the EEPROM to ensure the bit cell thresholds are within the specification for reliable EEPROM operation.

To perform the test, set the volatile MARGIN\_START bit. Once set, the device enters the test mode where all bit cells within the EEPROM array are checked. The EEPROM margining is selectable to check all logic 1 thresholds (can be disabled by MARGIN\_NO\_MAX), logic 0 thresholds (can be disabled by MARGIN\_NO\_MIN), or both thresholds.

**Table 8: Margin Status Return Decoding**

MARGIN_STATUS	Meaning
0	Reset condition (no result from margin testing)
1	Pass, no failure detected during margin testing
2	Fail, failure detected during margin testing
3	Running, margin test is still running

The EEPROM margin test takes 1 ms (typ). After the EEPROM margin test has completed, the status can be read out via the MARGIN\_STATUS bit in the volatile space. The best practice is to perform EEPROM margin checking after end-of-line programming.

### MEMORY ACCESS

The A31301 uses a primary and extended memory structure. The device uses EEPROM to permanently store configuration parameters for operation. EEPROM is user-programmable and permanently stores operation parameter values or customer information. The operation parameters are downloaded to shadow (volatile) memory at power-up. Shadow fields are initially loaded from corresponding fields in EEPROM, but can be overwritten, either by performing an extended write to the shadow addresses, or by reprogramming the corresponding EEPROM fields and power-cycling the IC. Use of shadow memory is substantially faster than accessing EEPROM. In situations where many parameters need to be tested quickly, shadow memory is recommended for trying parameter values before permanently programming them into EEPROM. The shadow memory registers have the same format as the EEPROM and are accessed at extended addresses 0x20 higher than the equivalent EEPROM address. Unused bits in the EEPROM do not exist in the related shadow register and returns 0 when read. Shadow registers do not contain the ECC bits. The serial interface primary access registers can be read or written to without the customer access code. The mapping of bits from register addresses in EEPROM to their corresponding register addresses in shadow is shown in the EEPROM tables in the indirect memory section. The access register is used to unlock the device. The access code must be written to ACCESS\_KEY [15:0] one byte at a time. Once unlocked, EEPROM and shadow registers may be written.

Extended access is provided to additional memory space via the primary registers. This access includes the EEPROM, shadow registers, and registers for additional status and diagnostics. All extended registers are 32 bits wide.

#### Customer Access Modes

The device memory contains nonvolatile EEPROM and volatile registers that are accessible via the serial interface through SPI or I<sup>2</sup>C communication mode. The memory address space is divided into three areas: factory, customer, and general access.

Customer access is controlled by an access code shown in Table 9. The access codes contain 32 bits.

To send the access codes shown in Table 9, the user writes to the Access register with four consecutive 8-bit writes.

When the customer access code is received, factory registers are addressable but are read-only.

**Table 9: 32-bit Customer Access Code**

	Byte 1	Byte 2	Byte 3	Byte 4
Customer (Read access to fact)	0x43	0x55	0x53	0x54

#### SENDING ACCESS CODE, I<sup>2</sup>C

Sending the access code to the A31301 using the I<sup>2</sup>C interface is outlined in the sequence below.

1. Controller initiates start condition
2. Controller sends 7-bit peripheral address and the write bit (0)
3. Controller waits for ACK from A31301
4. Controller sends 6-bit register address for the access key (0x3E)
5. Controller waits for ACK from A31301
6. Controller sends Byte 1 of the access code (0x43)
7. Controller waits for ACK from A31301
8. Controller sends Byte 2 of the access code (0x55)
9. Controller waits for ACK from A31301
10. Controller initiates stop condition
11. Controller initiates start condition
12. Controller sends 7-bit peripheral address and the write bit (0)
13. Controller waits for ACK from A31301
14. Controller sends 6-bit register address for the access key (0x3E)
15. Controller waits for ACK from A31301
16. Controller sends Byte 3 of the access code (0x53)
17. Controller waits for ACK from A31301
18. Controller sends Byte 4 of the access code (0x54)
19. Controller waits for ACK from A31301
20. Controller initiates stop condition

#### SENDING ACCESS CODE, SPI

Sending the access code to the A31301 using the SPI interface is outlined in the sequence below.

1. Controller sends a write command to the 6-bit register address for the access key (0x3E) with the data byte 1 of the access code (0x43)

2. Controller sends a write command to the 6-bit register address for the access key (0x3E) with the data byte 2 of the access code (0x55)
3. Controller sends a write command to the 6-bit register address for the access key (0x3E) with the data byte 3 of the access code (0x53)
4. Controller sends a write command to the 6-bit register address for the access key (0x3E) with the data byte 4 of the access code (0x54)

## Read Transaction from EEPROM (or Shadow Memory)

Invoking an extended read access is a three-step process:

1. Load the INDIRECT\_RD\_ADDR parameter with the target extended address. INDIRECT\_RD\_ADDR is the 8-bit extended address that determines which extended memory address is accessed.
2. Invoke the extended access by writing the primary INDIRECT\_RD\_STATUS register EXR bit with 1. The INDIRECT\_RD\_ADDR address is then read, and the data is loaded into the INDIRECT\_RD\_DATA\_MSB and INDIRECT\_RD\_DATA\_LSB registers.
3. Read the INDIRECT\_RD\_DATA\_MSB and INDIRECT\_RD\_DATA\_LSB registers to get the extended data. This takes multiple packets to obtain all 32 bits.

The RDN bit in the INDIRECT\_RD\_STATUS register can be polled to determine if the read access is complete before reading the data. Shadow register reads complete in one system clock cycle after synchronization. Do not attempt to read the INDIRECT\_RD\_DATA\_MSB and INDIRECT\_RD\_DATA\_LSB registers if the read access is potentially in process, because it could change during serial access and the data would be inconsistent. It is also possible that an SPI CRC error would be detected if the data were to change during the serial read via the SPI interface.

For example, to read location 0x1F in the EEPROM:

- Write 0x1F to the lower 8 bits of INDIRECT\_RD\_ADDR (0x1F to Address 0x0B)
- Write 0x80 to INDIRECT\_RD\_STATUS
- Read INDIRECT\_RD\_STATUS until bit 0 (RDN) is set (or wait enough time)
- Read INDIRECT\_RD\_DATA\_MSB (upper 16 bits of read data)
- Read INDIRECT\_RD\_DATA\_LSB (lower 16 bits of read data)

## Write Transaction to EEPROM (or Shadow Memory)

Invoking an extended write access is a three-step process:

1. Load the INDIRECT\_WR\_ADDR parameter with the target extended address.
2. Load the INDIRECT\_WR\_DATA\_MSB and INDIRECT\_WR\_DATA\_LSB registers with the data to be written to the target. This takes multiple writes to load all 32 bits of data.
3. Invoke the extended access by writing the primary INDIRECT\_WR\_STATUS register EXW bit with 1.

The INDIRECT\_WR\_ADDR address is then written with the 32-bit INDIRECT\_WR\_DATA\_MSB and INDIRECT\_WR\_DATA\_LSB data. The WDN bit in the INDIRECT\_WR\_STATUS register can be polled to determine when the write completes.

## Shadow Memory Read and Write Transactions

Shadow memory read and write transactions are identical to those for EEPROM. Instead of addressing to the EEPROM addresses, one must address to the shadow extended addresses, which are located at an offset of 0x20 above the EEPROM.

## Shared Factory and Customer Trim Registers

The memory contents in addresses 0x07 through 0x12 contain registers used to factory-trim the devices for highest sensing accuracy in any application where the input vectors match in amplitude. If the application requires additional end-of-line adjustment of the device trim these registers can be adjusted by the customer.

NOTE: It is up to the customer to ensure accuracy of the device after end-of-line programming.

## Memory Access in Low-Power Modes

When in sleep mode or low-power duty cycle mode, OP\_MODE = 3-6, Read/Write access is limited to critical registers to help conserve power. Only a subset of the direct space registers are available that are necessary to use the part in normal operation. Writes are only possible to direct space addresses 0x32-0x33, which contains device configuration parameters. For reads, direct space address 0x12-0x2B and 0x32-0x33 are available in the I<sup>2</sup>C interface and 0x1C-0x2A and 0x32-0x33 for the SPI interface. See the MEMORY MAP section for more information on the contents of these registers.

### MEMORY MAP

The A31301 uses a primary and extended memory structure designated as direct (primary) and indirect (extended) space.

#### Direct Primary Space

Table 10: Direct Memory Map

MSByte Address	LSByte Address	Register Name	MSByte								LSByte							
			15	14	13	12	11	10	9	8	7	6	5	4	3	2	1	0
0x0	0x1	NOP Register	0	0	0	0	0	0	0	0	0	0	0	0	0	0	0	0
0x2 to 0x8	0x3 to 0x9	Indirect Write Registers	Indirect Write Registers															
0xA to 0x10	0xB to 0x11	Indirect Read Registers	Indirect Read Registers															
0x12 to 0x1A	0x13 to 0x1B	I2C Only Registers	I2C Only Registers															
0x1C to 0x30	0x1D to 0x31	Output Registers	Output Registers															
0x32	0x33	Control Register 1	Control Register 1															
0x34	0x35	I2C Loopback Register	I2C Loopback Register															
0x36	0x37	Control Register 2	Control Register 2															
0x38	0x39	Control Register 3	Control Register 3															
0x3A	0x3B	Control Register 4	Control Register 4															
0x3C	0x3D	Reserved Register	Reserved Register															
0x3E	0x3F	Access Key Register	Access Key Register															

The direct register map is the main access point to the information of the device. During normal operation, the host requests information from the device by reading the direct register. This is output/status information, or volatile configuration parameters. Non-volatile configuration of the device, and certain volatile test features are accessible by using the indirect write/read registers

Table 11: NOP Register

MSByte Address	LSByte Address	Register Name	MSByte								LSByte							
			15	14	13	12	11	10	9	8	7	6	5	4	3	2	1	0
0x0	0x1	volatile	0	0	0	0	0	0	0	0	0	0	0	0	0	0	0	0

**Table 12: Indirect Write Registers**

MSByte Address	LSByte Address	Register Name	MSByte								LSByte								
			15	14	13	12	11	10	9	8	7	6	5	4	3	2	1	0	
0x2	0x3	INDIRECT_WR_ADDRESS	0	0	0	0	0	0	0	0	INDIRECT_WR_ADDR								
0x4	0x5	INDIRECT_WR_DATA_MSB	INDIRECT_WR_DATA_3								INDIRECT_WR_DATA_2								
0x6	0x7	INDIRECT_WR_DATA_LSB	INDIRECT_WR_DATA_1								INDIRECT_WR_DATA_0								
0x8	0x9	INDIRECT_WR_STATUS	EXW	0	0	0	0	0	0	0	WIP	0	0	0	0	0	0	0	WDN

### INDIRECT\_WR\_ADDR (0x02:0x03 [7:0])

Address to be used for an extended write.

### INDIRECT\_WR\_DATA\_3 (0x04:0x05 [15:8])

Most significant 8 bits of data to be written to the extended space (Bits [31:24]).

### INDIRECT\_WR\_DATA\_2 (0x04:0x05 [7:0])

Next 8 bits of data to be written to the extended space (Bits [23:16]).

### INDIRECT\_WR\_DATA\_1 (0x06:0x07 [15:8])

Next 8 bits of data to be written to the extended space (Bits [15:8]).

### INDIRECT\_WR\_DATA\_0 (0x06:0x07 [7:0])

Least Significant 8 bits of data to be written to the extended space (Bits [7:0]).

### EXW (0x08:0x09 [15])

Initiate extended write by writing with 1. Sets WIP, clears WDN, always reads back 0.

### WIP (0x08:0x09 [8])

Extended write in progress when 1.

### WDN (0x08:0x09 [0])

Extended write done when 1.

**Table 13: Indirect Read Registers**

MSByte Address	LSByte Address	Register Name	MSByte								LSByte							
			15	14	13	12	11	10	9	8	7	6	5	4	3	2	1	0
0xA	0xB	INDIRECT_RD_ADDRESS	0	0	0	0	0	0	0	0	INDIRECT_RD_ADDR							
0xC	0xD	INDIRECT_RD_STATUS	EXR	0	0	0	0	0	0	RIP	0	0	0	0	0	0	0	RDN
0xE	0xF	INDIRECT_RD_DATA_MSB	INDIRECT_RD_DATA_3								INDIRECT_RD_DATA_2							
0x10	0x11	INDIRECT_RD_DATA_LSB	INDIRECT_RD_DATA_1								INDIRECT_RD_DATA_0							

### INDIRECT\_RD\_ADDR (0x0A:0x0B [7:0])

Address to be used for an extended read.

### EXR (0x0C:0x0D [15])

Initiate extended read by writing with 1. Sets RIP, clears RDN, always reads back 0.

### RIP (0x0C:0x0D [8])

Extended read in progress when 1.

### RDN (0x08:0x09 [0])

Extended read done when 1.

### INDIRECT\_RD\_DATA\_3 (0x0E:0x0F [15:8])

Most significant 8 bits of data returned from the extended space (Bits [31:24]).

### INDIRECT\_RD\_DATA\_2 (0x0E:0x0F [7:0])

Next 8 bits of data returned from the extended space (Bits [23:16]).

### INDIRECT\_RD\_DATA\_1 (0x10:0x11 [15:8])

Next 8 bits of data returned from the extended space (Bits [15:8]).

### INDIRECT\_RD\_DATA\_0 (0x10:0x11 [7:0])

Least Significant 8 bits of data returned from the extended space (Bits [7:0]).

**Table 14: I<sup>2</sup>C Only Registers**

MSByte Address	LSByte Address	Register Name	MSByte								LSByte							
			15	14	13	12	11	10	9	8	7	6	5	4	3	2	1	0
0x12	0x13	I2C_LOOP_BACK	I2C_LOOP_BACK_16B															
0x14	0x15	I2C_X_Y_8B	Y_CHANNEL_8B								X_CHANNEL_8B							
0x16	0x17	I2C_T_Z_8B	TEMPERATURE_8B								Z_CHANNEL_8B							
0x18	0x19	I2C_ANGLE_RADIUSSQ_8B	ANGLE_8B								RADIUS_SQ_8B							
0x1A	0x1B	I2C_SIN_COS_8B	SIN_8B								COS_8B							
0x34	0x35	I2C_LOOPBACK_CONF	0	0	0	0	0	0	0	0	I2C_LOOPBACK_CH_SEL							

Note: The registers listed here are exclusively for use in I<sup>2</sup>C device modes. In SPI mode, these registers are to be considered “do not read,” and any results read in from these registers is considered invalid. The digital ports (I<sup>2</sup>C/SPI) differ in their interfacing to the internal registers to accommodate different data speeds and other configurations. For SPI modes, please see the SPI section which follows.

### I2C\_LOOP\_BACK\_16B (0x12:0x13 [15:0])

This register provides the 16-bit result of the last channel read per the loop-back configuration register (See I2C\_LOOPBACK\_CH\_SEL).

### Y\_CHANNEL\_8B (0x14:0x15 [15:8])

This register provides a fast, partial, result of the Y-axis channel data. The upper 8 bits of the 15-bit register, (Y\_CHANNEL\_15B) is provided for the user, providing values of up to  $\pm 127$  counts for the channel data.

### X\_CHANNEL\_8B (0x14:0x15 [7:0])

This register provides a fast, partial, result of the X-axis channel data. The upper 8 bits of the 15-bit register, (X\_CHANNEL\_15B) is provided for the user, providing values of up to  $\pm 127$  counts for the channel data.

### TEMPERATURE\_8B (0x16:0x17 [15:8])

This register provides a fast, partial, result of the temperature sensor output data. The upper 8 bits of the 12-bit register, (TEMPERATURE\_12B) is provided for the user.

### Z\_CHANNEL\_8B (0x16:0x17 [7:0])

This register provides a fast, partial, result of the Z-axis channel data. The upper 8 bits of the 15-bit register, (Z\_CHANNEL\_15B) is provided for the user, providing values of up to  $\pm 127$  counts for the channel data.

### ANGLE\_8B (0x18:0x19 [15:8])

This register provides a fast, partial result of the Angle output register. The upper 8-bits of unsigned data are stored here from the 15-bit unsigned register (ANGLE\_15B). The angle register provides an output of 0-255 counts to represent either true angle (1.41176 degrees-per-LSB) or linear position (0.39215% per LSB).

### RADIUS\_SQ\_8B (0x18:0x19 [7:0])

This register provides a fast, partial result of the magnitude output register. The upper 8-bits of unsigned data are stored here from the 15-bit unsigned register (RADIUS\_15B). The radius-squared register provides a magnitude of sensed field, granting the user the capability of producing angle-vectors numerically without additional computational requirements on the host microcontroller.

### SIN\_8B (0x1A:0x1B [15:8])

This register provides a fast, signed output for the SINE channel input to the angle calculation. The upper 8-bits of unsigned data is stored here from the 15-bit signed register (SINE\_15B)

### COS\_8B (0x1A:0x1B [7:0])

This register provides a fast, signed output for the COSINE channel input to the angle calculation. The upper 8-bits of unsigned data is stored here from the 15-bit signed register (COSINE\_15B)

### I2C\_LOOPBACK\_CH\_SEL (0x34:0x35 [7:0])

This register serves to configure the power saving options of the A31301. Here, the operational mode (active, low-power duty-cycling, sleep) is configured, and any subsequent options pertaining to those modes are set.

**Table 15: Output Registers**

MSByte Address	LSByte Address	Register Name	MSByte								LSByte							
			15	14	13	12	11	10	9	8	7	6	5	4	3	2	1	0
0x1C	0x1D	TEMPERATURE	0	0	0	0	TEMPERATURE_12B											
0x1E	0x1F	X_CHANNEL	0	X_CHANNEL_15B														
0x20	0x21	Y_CHANNEL	0	Y_CHANNEL_15B														
0x22	0x23	Z_CHANNEL	0	Z_CHANNEL_15B														
0x24	0x25	ANGLE	0	ANGLE_15B														
0x26	0x27	RADIUS	0	RADIUS_15B														
0x28	0x29	SINE	0	SINE_15B														
0x2A	0x2B	COSINE	0	COSINE_15B														
0x2C	0x2D	X_RAW_FILT_OUT	0	X_RAW_FILT_OUT_15B														
0x2E	0x2F	Y_RAW_FILT_OUT	0	Y_RAW_FILT_OUT_15B														
0x30	0x31	Z_RAW_FILT_OUT	0	Z_RAW_FILT_OUT_15B														

### TEMPERATURE\_12B (0x1C:0x1D[11:0])

This register holds the 12-bit signed temperature sensor output.

### X\_CHANNEL\_15B (0x1E:0x1F[14:0])

This register holds the 15-bit signed output of the X-axis sensor output.

### Y\_CHANNEL\_15B (0x20:0x21[14:0])

This register holds the 15-bit signed output of the Y-axis sensor output.

### Z\_CHANNEL\_15B (0x22:0x23[14:0])

This register holds the 15-bit signed output of the Z-axis sensor output.

### ANGLE\_15B (0x24:0x25[14:0])

This register holds the unsigned output of the calculated angle. When handled as an angle, the register output is 0.0109863°/LSB. When used as a linear position output, each bit holds a value of 0.0030518%/LSB.

### RADIUS\_15B (0x26:0x27 [14:0])

This register provides a magnitude (squared) of sensed field, granting the user the capability of producing angle vectors numerically without additional computational requirements on the host microcontroller.

### SINE\_15B (0x28:0x29 [14:0])

This register provides a signed output for the SINE channel input to the angle calculation set by CORDIC\_SEL.

### COSINE\_15B (0x2A:0x2B[14:0])

This register provides a signed output for the COSINE channel input to the angle calculation set by CORDIC\_SEL.

### X\_RAW\_FILT\_OUT\_15B (0x2C:0x2D[14:0])

This register provides the raw output of the X-channel before any trim is applied. This can be useful for debugging issues with expected output in the X\_CHANNEL\_15B output.

### Y\_RAW\_FILT\_OUT\_15B (0x2E:0x2F[14:0])

This register provides the raw output of the Y-channel before any trim is applied. This can be useful for debugging issues with expected output in the Y\_CHANNEL\_15B output.

### Z\_RAW\_FILT\_OUT\_15B (0x30:0x31[14:0])

This register provides the raw output of the Z-channel before any trim is applied. This can be useful for debugging issues with expected output in the Z\_CHANNEL\_15B output.

**Table 16: Control Registers**

MSByte Address	LSByte Address	Register Name	MSByte								LSByte							
			15	14	13	12	11	10	9	8	7	6	5	4	3	2	1	0
0x32	0x33	OP_MODE_CONF	0	0	0	START_SAMPLE	INTERRUPT_FLAG	STATUS_READY	0	0	0	SLEEP_CNT			OP_MODE			0
0x36	0x37	INT_THR_CONF_DIR	0	0	0	0	INTERRUPT_THR_MSB_DIR			INTERRUPT_THR_LSB_DIR								
0x38	0x39	INT_XYZ_CONF_DIR	0	0	AFE_CHAN_DIS_Z_DIR	AFE_CHAN_DIS_Y_DIR	AFE_CHAN_DIS_X_DIR	POL_F_Z_DIR	POL_F_Y_DIR	POL_F_X_DIR	0	INTERRUPT_SEL_DIR			INTERRUPT_SIGN_DIR	INTERRUPT_FLAG_LATCH_DIR	SAMPLE_INT_POLARITY_DIR	
0x3A	0x3B	CIC_CORDIC_CONF_DIR	0	0	0	0	0	CIC_BW_SEL_LPM_DIR			0	CIC_BW_SEL_DIR		CORDIC_POL_DIR	CORDIC_SEL_DIR			

### START\_SAMPLE (0x32:0x33[12])

If STATUS\_READY parameter is cleared, the START\_SAMPLE parameter triggers an internal conversion to begin. Device is in standby mode until this parameter is set, or the INT/SAMPLE pin is pulled to active state.

### INTERRUPT\_FLAG (0x32:0x33[11])

This is a latched bit that asserts to 1 when an interrupt occurs. The interrupt functionality is set by INTERRUPT\_SEL\_DIR in the direct space or INT\_SEL in the indirect space. This bit must be set to 0 by a write from the host.

### STATUS\_READY (0x32:0x33[10])

This is a latched bit that indicates a new sample is ready after the START\_SAMPLE bit is set to start a new conversion. This bit must be set to 0 by a write from the host.

### SLEEP\_CNT (0x32:0x33[6:4])

The SLEEP\_CNT parameter controls the low power duty cycle mode inactive time. See Operation Modes section for decode.

### OP\_MODE (0x32:0x33[3:1])

OP\_MODE sets the operation configuration of the A31301 with regards to power use. The different options are described in the Operation Modes section.

### INTERRUPT\_THR\_MSB\_DIR (0x36:0x37[11:8])

This parameter sets the MSBs of the programmable threshold for the interrupt functionality. See Interrupt Mode in the Special Function Pin section for more information.

### INTERRUPT\_THR\_LSB\_DIR (0x36:0x37[7:0])

This parameter sets the LSBs of the programmable threshold for the interrupt functionality. See Interrupt Mode in the Special Function Pin section for more information.

### AFE\_CHAN\_DIS\_Z\_DIR (0x38:0x39[13])

This is a direct space copy of the AFE\_CHAN\_DIS\_Z bit from indirect space. Z-channel disable, shuts off the Z-channel to reduce power and processing time if unused.

### AFE\_CHAN\_DIS\_Y\_DIR (0x38:0x39[12])

This is a direct space copy of the AFE\_CHAN\_DIS\_Y bit from indirect space. Y-channel disable, shuts off the Y-channel to reduce power and processing time if unused.

### AFE\_CHAN\_DIS\_X\_DIR (0x38:0x39[11])

This is a direct space copy of the AFE\_CHAN\_DIS\_X bit from indirect space. X-channel disable, shuts off the X-channel to reduce power and processing time if unused.

### POL\_F\_Z\_DIR (0x38:0x39[10])

This is a direct space copy of the POL\_F\_Z bit from indirect space which flips the polarity of the Z-channel output.

### POL\_F\_Y\_DIR (0x38:0x39[9])

This is a direct space copy of the POL\_F\_Y bit from indirect space which flips the polarity of the Y-channel output.

### POL\_F\_X\_DIR (0x38:0x39[8])

This is a direct space copy of the POL\_F\_X bit from indirect space which flips the polarity of the X-channel output.

### INTERRUPT\_SEL\_DIR (0x38:0x39[6:3])

This is a direct space copy of the INT\_SEL parameter from indirect space. This selects the signal to compare against the programmed threshold in INTERRUPT\_THR\_MSB/LSB\_DIR as shown in the table in the Interrupt Mode in the Special Function Pin section.

### INTERRUPT\_SIGN\_DIR (0x38:0x39[2])

This is a direct space copy of the INT\_SIGN parameter from indirect space. This selects the sign of the comparison to the threshold to set the interrupt from signal less than the programmed threshold (0, default) to signal greater than the programmed threshold (1). See the Interrupt Mode in the Special Function Pin section for more information.

### INTERRUPT\_FLAG\_LATCH\_DIR (0x38:0x39[1])

This is a direct space copy of the INT\_FLAG\_LATCH parameter from indirect space. This sets whether the INT/SAMPLE pin latches asserted when the condition is removed. The default, 0,

case is the INT/SAMPLE pin output does not stay asserted. See the Interrupt Mode in the Special Function Pin section for more information.

### SAMPLE\_INT\_POLARITY\_DIR (0x38:0x39[0])

This is a direct space copy of SMPL\_INT\_POL. Controls polarity of the special function bin to be active low (0, default) or active high (1).

### CORDIC\_BW\_SEL\_LPM\_DIR (0x3A:0x3B[10:8])

This is a direct space copy of the CIC\_BW\_SEL\_LPM parameter in indirect space. Sets the BW in low-power mode (OP\_MODE = 3,4). Sets the amount of time the part is awake making conversions for each active channel before returning to sleep. See Bandwidth Selection and Low Power Duty Cycle Mode (LPDCM) sections for more information.

### CORDIC\_BW\_SEL\_DIR (0x3A:0x3B[6:4])

This is a direct space copy of the CIC\_BW\_SEL parameter in indirect space. Sets the BW in active mode (OP\_MODE = 0,1, or 2). See Bandwidth Selection section for more information.

### CORDIC\_POL\_DIR (0x3A:0x3B[3])

This is a direct space copy of the CORIC\_POL parameter in indirect space. This sets the output to be increasing in code or decreasing in code for an increasing magnetic angle input. See Magnetic Sensor(s) Output for more information.

### CORDIC\_SEL\_DIR (0x3A:0x3B[2:0])

This is a direct space copy of the CORIC\_SEL parameter in indirect space. This sets the two channels used for the ATAN angle calculation. See Magnetic Sensor(s) Output for more information.

**Table 17: Reserved Register**

MSByte Address	LSByte Address	Register Name	MSByte								LSByte							
			15	14	13	12	11	10	9	8	7	6	5	4	3	2	1	0
0x3C	0x3D	RESERVED	RESERVED															

### RESERVED (0x3C:0x3D[15:0])

This register is reserved for factory use and should be left as zero for device functionality to be maintained.

**Table 18: Access Register**

MSByte Address	LSByte Address	Register Name	MSByte								LSByte							
			15	14	13	12	11	10	9	8	7	6	5	4	3	2	1	0
0x3E	0x3F	ACCESS	ACCESS_KEY															

### ACCESS\_KEY (0x3E:0x3F[15:0])

Location for sending the access code to the device. See Memory Access on page 23 section for instruction.

### Indirect Extended Space

ECC\_\* parameters contain ECC error flags in the event of a single- or multi-bit error being detected in a row.

UNUSED\_\* parameters are empty space in the memory that have no function.

**Table 19: EEPROM/Shadow Memory: ID Parameters**

EEPROM Address	Shadow Address	Bit																											
		31 to 26	25	24	23	22	21	20	19	18	17	16	15	14	13	12	11	10	9	8	7	6	5	4	3	2	1	0	
0x0	N/A	ECC_0	FACTORY_ID_0				Y_DIE_LOC								X_DIE_LOC								EEPROM_REV						
0x1	N/A	ECC_1	FACTORY_ID_1				FACTORY_LOT																FACTORY_WAFER						

### FACTORY\_ID\_0 (EEPROM: 0x00, Shadow: None [25:22])

Factory-use identification parameter.

### Y\_DIE\_LOC (EEPROM: 0x00, Shadow: None [21:14])

Die location on wafer in Y dimension.

### X\_DIE\_LOC (EEPROM: 0x00, Shadow: None [13:6])

Die location on wafer in X dimension.

### EEPROM\_REV (EEPROM: 0x00, Shadow: None [5:0])

EEPROM revision.

### FACTORY\_ID\_1 (EEPROM: 0x01, Shadow: None [25:22])

Factory-use identification parameter.

### FACTORY\_LOT (EEPROM: 0x01, Shadow: None [21:6])

Factory lot number.

### FACTORY\_WAFER (EEPROM: 0x01, Shadow: None [5:0])

Factory wafer number in lot.

**Table 20: EEPROM/Shadow Memory: Trim Parameters**

EEPROM Address	Shadow Address	Bit																											
		31 to 26	25	24	23	22	21	20	19	18	17	16	15	14	13	12	11	10	9	8	7	6	5	4	3	2	1	0	
0x7	0x27	ECC_7				UNUSED_07								POL_F_X	AFE_CHAN_DIS_X	SENS_F_X													
0x8	0x28	ECC_8				UNUSED_08								POL_F_Y	AFE_CHAN_DIS_Y	SENS_F_Y													
0x9	0x29	ECC_9				UNUSED_09								POL_F_Z	AFE_CHAN_DIS_Z	SENS_F_Z													
0xD	0x2D	ECC_D				UNUSED_0D				SENSTC_CLD_F_X								OFFSTC_CLD_F_X											
0xE	0x2E	ECC_E				UNUSED_0E				SENSTC_CLD_F_Y								OFFSTC_CLD_F_Y											
0xF	0x2F	ECC_F				UNUSED_0F				SENSTC_CLD_F_Z								OFFSTC_CLD_F_Z											
0x10	0x30	ECC_10				UNUSED_10				SENSTC_HOT_F_X								OFFSTC_HOT_F_X											
0x11	0x31	ECC_11				UNUSED_11				SENSTC_HOT_F_Y								OFFSTC_HOT_F_Y											
0x12	0x32	ECC_12				UNUSED_12				SENSTC_HOT_F_Z								OFFSTC_HOT_F_Z											

**POL\_F\_X (EEPROM: 0x07, Shadow: 0x27 [15])**

X-channel polarity bit.

**AFE\_CHAN\_DIS\_X (EEPROM: 0x07, Shadow: 0x27 [14])**

X-channel disable, shuts off the X-channel to reduce power and processing time if unused.

**SENS\_F\_X (EEPROM: 0x07, Shadow: 0x27 [13:0])**

X-channel sensitivity adjustment. Used to align the channels at the factory trim, and available for corrections when installed in application. Note if this parameter is adjusted in application, factory accuracy is no longer ensured.

Range: 0× to 8×.

Step Size: 2<sup>-11</sup>.

**POL\_F\_Y (EEPROM: 0x08, Shadow: 0x28 [15])**

Y-channel polarity bit.

**AFE\_CHAN\_DIS\_Y (EEPROM: 0x08, Shadow: 0x28 [14])**

Y-channel disable, shuts off the Y-channel to reduce power and processing time if unused.

**SENS\_F\_Y (EEPROM: 0x08, Shadow: 0x28 [13:0])**

Y-channel sensitivity adjustment. Used to align the channels at the factory trim, and available for corrections when installed in application. Note if this parameter is adjusted in application, factory accuracy is no longer ensured.

Range: 0× to 8×.

Step Size: 2<sup>-11</sup>.

**POL\_F\_Z (EEPROM: 0x09, Shadow: 0x29 [15])**

Z-channel polarity bit.

**AFE\_CHAN\_DIS\_Z (EEPROM: 0x09, Shadow: 0x29 [14])**

Z-channel disable, shuts off the Z-channel to reduce power and processing time if unused.

**SENS\_F\_Z (EEPROM: 0x09, Shadow: 0x29 [13:0])**

Z-channel sensitivity adjustment. Used to align the channels at the factory trim, and available for corrections when installed in application. Note if this parameter is adjusted in application, factory accuracy is no longer ensured.

Range: 0× to 8×.

Step Size: 2<sup>-11</sup>.

### SENSTC\_CLD\_F\_X (EEPROM: 0x0D, Shadow: 0x2D [22:12])

X-channel sensitivity adjustment for  $-40^{\circ}\text{C} \leq T_A < 25^{\circ}\text{C}$  temperature segment. Used to align the channels at the factory trim to a target compensation, and available for corrections when installed in application. Note if this parameter is adjusted in application, factory accuracy is no longer ensured.

Range:  $\pm 0.78\%/^{\circ}\text{C}$ .

Step Size:  $-7.63\text{e-}4\%/^{\circ}\text{C}$ .

### OFFSETC\_CLD\_F\_X (EEPROM: 0x0D, Shadow: 0x2D [11:0])

X-channel offset adjustment for  $-40^{\circ}\text{C} \leq T_A < 25^{\circ}\text{C}$  temperature segment. Used to correct the channels offset at the factory trim in the cold temperature segment, and available for corrections when installed in application. Note if this parameter is adjusted in application, factory accuracy is no longer ensured.

Range:  $\pm 64 \text{ LSB}_{15}/^{\circ}\text{C}$ .

Step Size:  $-0.0313 \text{ LSB}_{15}\%/^{\circ}\text{C}$ .

### SENSTC\_CLD\_F\_Y (EEPROM: 0x0E, Shadow: 0x2E [22:12])

Y-channel sensitivity adjustment for  $-40^{\circ}\text{C} \leq T_A < 25^{\circ}\text{C}$  temperature segment. Used to align the channels at the factory trim to a target compensation, and available for corrections when installed in application. Note if this parameter is adjusted in application, factory accuracy is no longer ensured.

Range:  $\pm 0.78\%/^{\circ}\text{C}$ .

Step Size:  $-7.63\text{e-}4\%/^{\circ}\text{C}$ .

### OFFSETC\_CLD\_F\_Y (EEPROM: 0x0E, Shadow: 0x2E [11:0])

Y-channel offset adjustment for  $-40^{\circ}\text{C} \leq T_A < 25^{\circ}\text{C}$  temperature segment. Used to correct the channels offset at the factory trim in the cold temperature segment, and available for corrections when installed in application. Note if this parameter is adjusted in application, factory accuracy is no longer ensured.

Range:  $\pm 64 \text{ LSB}_{15}/^{\circ}\text{C}$ .

Step Size:  $-0.0313 \text{ LSB}_{15}\%/^{\circ}\text{C}$ .

### SENSTC\_CLD\_F\_Z (EEPROM: 0x0F, Shadow: 0x2F [22:12])

Z-channel sensitivity adjustment for  $-40^{\circ}\text{C} \leq T_A < 25^{\circ}\text{C}$  temperature segment. Used to align the channels at the factory trim to a target compensation, and available for corrections when installed in application. Note if this parameter is adjusted in application, factory accuracy is no longer ensured.

Range:  $\pm 0.78\%/^{\circ}\text{C}$ .

Step Size:  $-7.63\text{e-}4\%/^{\circ}\text{C}$ .

### OFFSETC\_CLD\_F\_Z (EEPROM: 0x0F, Shadow: 0x2F [11:0])

Z-channel offset adjustment for  $-40^{\circ}\text{C} \leq T_A < 25^{\circ}\text{C}$  temperature segment. Used to correct the channels offset at the factory trim in the cold temperature segment, and available for corrections when installed in application. Note if this parameter is adjusted in application, factory accuracy is no longer ensured.

Range:  $\pm 64 \text{ LSB}_{15}/^{\circ}\text{C}$ .

Step Size:  $-0.0313 \text{ LSB}_{15}\%/^{\circ}\text{C}$ .

### SENSTC\_HOT\_F\_X (EEPROM: 0x10, Shadow: 0x30 [22:12])

X-channel sensitivity adjustment for  $25^{\circ}\text{C} < T_A \leq 85^{\circ}\text{C}$  temperature segment. Used to align the channels at the factory trim to a target compensation, and available for corrections when installed in application. Note if this parameter is adjusted in application, factory accuracy is no longer ensured.

Range:  $\pm 0.39\%/^{\circ}\text{C}$ .

Step Size:  $3.81\text{e-}4\%/^{\circ}\text{C}$ .

### OFFSETC\_HOT\_F\_X (EEPROM: 0x10, Shadow: 0x30 [11:0])

X-channel offset adjustment for  $25^{\circ}\text{C} < T_A \leq 85^{\circ}\text{C}$  temperature segment. Used to correct the channels offset at the factory trim in the cold temperature segment, and available for corrections when installed in application. Note if this parameter is adjusted in application, factory accuracy is no longer ensured.

Range:  $\pm 32 \text{ LSB}_{15}/^{\circ}\text{C}$ .

Step Size:  $0.0156 \text{ LSB}_{15}\%/^{\circ}\text{C}$ .

### SENSTC\_HOT\_F\_Y (EEPROM: 0x11, Shadow: 0x31 [22:12])

Y-channel sensitivity adjustment for  $25^{\circ}\text{C} < T_A \leq 85^{\circ}\text{C}$  temperature segment. Used to align the channels at the factory trim to a target compensation, and available for corrections when installed in application. Note if this parameter is adjusted in application, factory accuracy is no longer ensured.

Range:  $\pm 0.39\%/^{\circ}\text{C}$ .

Step Size:  $3.81\text{e-}4\%/^{\circ}\text{C}$ .

### OFFSETC\_HOT\_F\_Y (EEPROM: 0x11, Shadow: 0x31 [11:0])

Y-channel offset adjustment for  $25^{\circ}\text{C} < T_A \leq 85^{\circ}\text{C}$  temperature segment. Used to correct the channels offset at the factory trim in the cold temperature segment, and available for corrections when installed in application. Note if this parameter is adjusted in application, factory accuracy is no longer ensured.

Range:  $\pm 32 \text{ LSB}_{15}/^{\circ}\text{C}$ .

Step Size:  $0.0156 \text{ LSB}_{15}\%/^{\circ}\text{C}$ .

### SENSTC\_HOT\_F\_Z (EEPROM: 0x12, Shadow: 0x32 [22:12])

Z-channel sensitivity adjustment for  $25^{\circ}\text{C} < T_A \leq 85^{\circ}\text{C}$  temperature segment. Used to align the channels at the factory trim to a target compensation, and available for corrections when installed in application. Note if this parameter is adjusted in application, factory accuracy is no longer ensured.

Range:  $\pm 0.39\%/^{\circ}\text{C}$ .

Step Size:  $3.81\text{e-}4\%/^{\circ}\text{C}$ .

### OFFSETC\_HOT\_F\_Z (EEPROM: 0x12, Shadow: 0x32 [11:0])

Z-channel offset adjustment for  $25^{\circ}\text{C} < T_A \leq 85^{\circ}\text{C}$  temperature segment. Used to correct the channels offset at the factory trim in the cold temperature segment, and available for corrections when installed in application. Note if this parameter is adjusted in application, factory accuracy is no longer ensured.

Range:  $\pm 32 \text{ LSB}_{15}/^{\circ}\text{C}$ .

Step Size:  $0.0156 \text{ LSB}_{15}\%/^{\circ}\text{C}$ .

**Table 21: EEPROM/Shadow Memory: Device Configuration Parameters**

EEPROM Address	Shadow Address	Bit																											
		31 to 26	25	24	23	22	21	20	19	18	17	16	15	14	13	12	11	10	9	8	7	6	5	4	3	2	1	0	
0x13	0x33	ECC_13				UNUSED_13			SMPL_INT_POL	INT_FLAG_LATCH	INT_SIGN	INT_SEL				INT_THR										CORDIC_POL	CORDIC_SEL		
0x14	0x34	ECC_14				UNUSED_14														CIC_BW_SEL_LPM			CIC_BW_SEL						
0x15	0x35	ECC_15				UNUSED_15			INT_EDGE_RATE	SPI_EDGE_RATE	SPI_CRC_EN	I2C_CRC_EN	I2C_SLV_ADDR_IGNORE	I2C_SLV_ADDR				I2C_THRESH_SEL	I2C_DIS_SLV_ADDR	SPARE_15			DATA_LATCH	INTERFACE_SELECT					

**SMPL\_INT\_POL (EEPROM: 0x13, Shadow: 0x33 [22])**

Controls polarity of the special function bin to be active low (0, default) or active high (1).

**INT\_FLAG\_LATCH (EEPROM: 0x13, Shadow: 0x33 [21])**

This sets whether or not the INT/SAMPLE pin latches asserted when the condition is removed. The default, 0, case is the INT/SAMPLE pin output does not stay asserted. See the Interrupt Mode in the Special Function Pin section for more information.

**INT\_SIGN (EEPROM: 0x13, Shadow: 0x33 [20])**

This selects the sign of the comparison to the threshold to set the interrupt from signal less than the programmed threshold (0, default) to signal greater than the programmed threshold (1). See the Interrupt Mode in the Special Function Pin section for more information.

**INT\_SEL (EEPROM: 0x13, Shadow: 0x33 [19:16])**

This selects the signal to compare against the programmed threshold in INTERRUPT\_THR\_MSB/LSB\_DIR as shown in the table in the Interrupt Mode in the Special Function Pin section.

**INT\_THR (EEPROM: 0x13, Shadow: 0x33 [15:4])**

This sets the threshold value for the interrupt comparison that is loaded into INTERRUPT\_THR\_MSB/LSB\_DIR upon a reset. See Interrupt Mode in the Special Function Pin section for more information.

**CORDIC\_POL (EEPROM: 0x13, Shadow: 0x33 [3])**

This sets the output to be increasing in code or decreasing in code for an increasing magnetic angle input. See Magnetic Sensor(s) Output for more information.

**CORDIC\_SEL (EEPROM: 0x13, Shadow: 0x33 [2:0])**

This sets the two channels used for the ATAN angle calculation. See Magnetic Sensor(s) Output for more information.

**CIC\_BW\_SEL\_LPM (EEPROM: 0x14, Shadow: 0x34 [5:3])**

Sets the BW in Low Power Mode (OP\_MODE = 3,4). Sets the amount of time the part is awake making conversions for each active channel before returning to sleep. See Bandwidth Selection and Low Power Duty Cycle Mode (LPDCM) sections for more information.

**CIC\_BW\_SEL (EEPROM: 0x14, Shadow: 0x34 [2:0])**

Sets the BW in active mode (OP\_MODE = 0, 1, or 2). See Bandwidth Selection section for more information.

**INT\_EDGE\_RATE (EEPROM: 0x15, Shadow: 0x35 [21])**

Interrupt output pin edge rate. Set to 0 for faster edge and higher speed communications, and 1 for slower edge for power savings.

**SPI\_EDGE\_RATE (EEPROM: 0x15, Shadow: 0x35 [20])**

SPI output edge filtering. Set to 0 for faster edge and higher speed communications, and 1 for slower edge for power savings.

**SPI\_CRC\_EN (EEPROM: 0x15, Shadow: 0x35 [19])**

This parameter enables the CRC on the SPI message. When set, the SPI packet is 20 bits: 16 bits of data and 4 bits of CRC. See the SPI Error Checking section for more information.

**I2C\_CRC\_EN (EEPROM: 0x15, Shadow: 0x35 [18])**

This parameter enables the CRC on the I<sup>2</sup>C message frame. When set, the 8-bit CRC is added to the read transaction. See the I<sup>2</sup>C CRC Byte section for more information.

**I2C\_SLV\_ADDR\_IGNORE (EEPROM: 0x15, Shadow: 0x35 [17])**

When this parameter is set, the device responds to any I<sup>2</sup>C command, ignoring the address.

**I2C\_SLV\_ADDR (EEPROM: 0x15, Shadow: 0x35 [16:10])**

Used to set the peripheral address for I<sup>2</sup>C communications when the external pins are set high, or I2C\_DIS\_SLV\_ADDR is set to one. See the I<sup>2</sup>C Addressing section for more information.

**I2C\_THRESH\_SEL (EEPROM: 0x15, Shadow: 0x35 [9])**

This parameter sets the input thresholds for the I<sup>2</sup>C communication to either 3.0 V compatible (0, default) or 1.8 V compatible (1).

**I2C\_DIS\_SLV\_ADDR (EEPROM: 0x15, Shadow: 0x35 [8])**

Disable the external I<sup>2</sup>C address pins and latches the current address. The address pins are constantly scanned after power on to check for change in address. If this bit is set, the last detected address is latched. If this is set at power on, the address is set to 96.

**SPARE\_15 (EEPROM: 0x15, Shadow: 0x35 [7:2])**

Unused space in the EEPROM.

**DATA\_LATCH (EEPROM: 0x15, Shadow: 0x35 [1])**

This parameter allows disabling the latching feature of the output registers. When set to zero, the registers continuously updates as soon as a new sample is ready for each independent register. When set to 1, the output registers latches from the same point in time allowing the host to read each register without them updating. To initiate a new latching of the data when DATA\_LATCH = 1, the STATUS\_READY bit must be cleared.

**INTERFACE\_SELECT (EEPROM: 0x15, Shadow: 0x35 [0])**

Sets the active interface to I<sup>2</sup>C when 0, and to SPI when 1.



### PACKAGE OUTLINE DRAWING

For Reference Only – Not for Tooling Use

(Reference DWG-0000372)

Dimensions in millimeters – NOT TO SCALE

Exact case and lead configuration at supplier discretion within limits shown

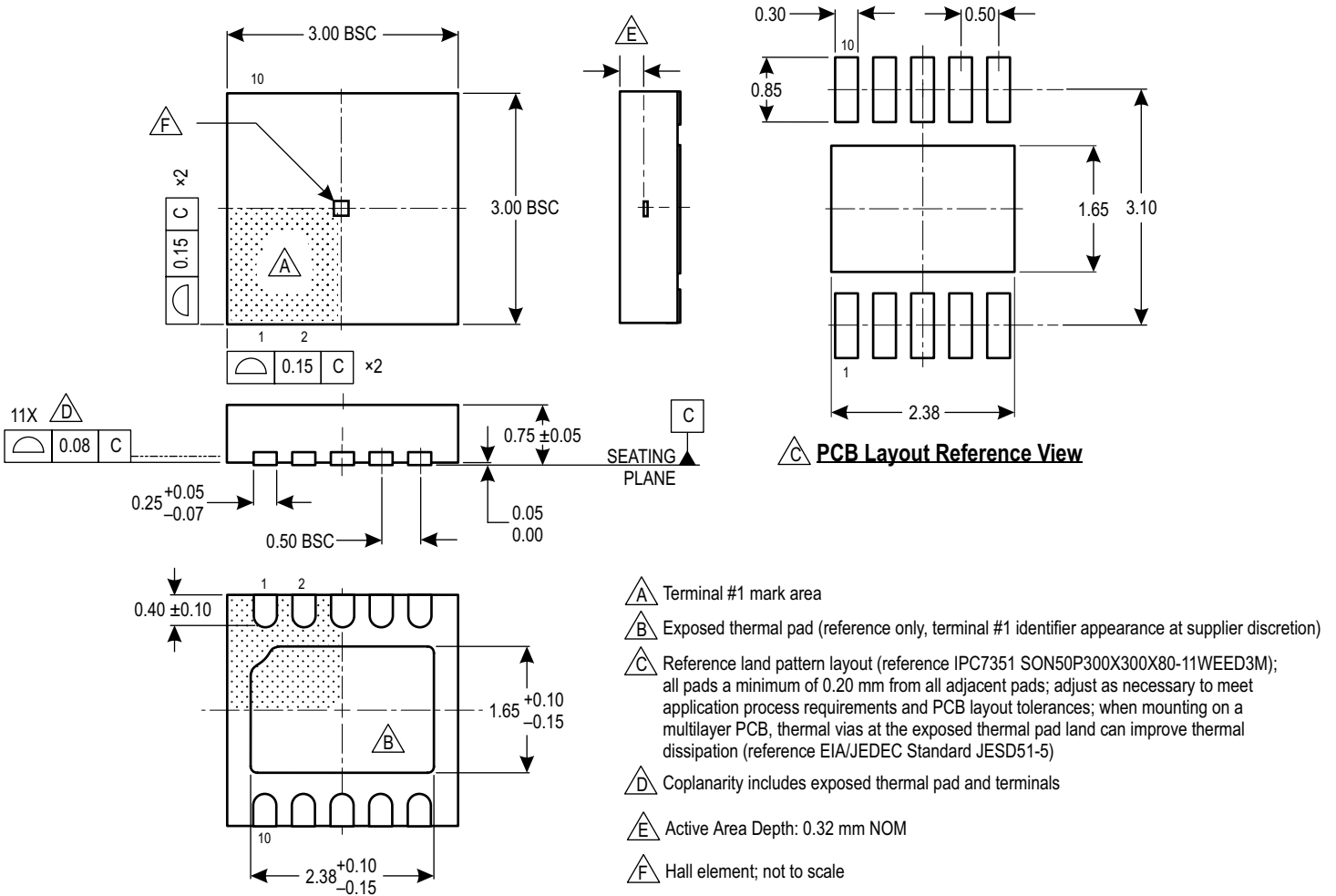

Figure 13: DFN-10 (EJ) Package Drawing

### Revision History

Number	Date	Description
–	September 18, 2023	Initial release
1	December 4, 2023	Updated Naming Specification (page 2), Terminal List (p. 5, Pin 4), Footnote 5 (page 6), and Performance Characteristic table headings (pages 9-11); corrected package drawing (page 38)
2	March 2, 2026	General editorial updates throughout. Clarified pin connection on functional block diagram (page 1). Updated selection guide (page 2). Clarified access code as hexadecimal (page 23). Added sections clarifying sequence to send access code to the device (pages 23 and 24).

Copyright 2026, Allegro MicroSystems.

Allegro MicroSystems reserves the right to make, from time to time, such departures from the detail specifications as may be required to permit improvements in the performance, reliability, or manufacturability of its products. Before placing an order, the user is cautioned to verify that the information being relied upon is current.

Allegro's products are not to be used in any devices or systems, including but not limited to life support devices or systems, in which a failure of Allegro's product can reasonably be expected to cause bodily harm.

The information included herein is believed to be accurate and reliable. However, Allegro MicroSystems assumes no responsibility for its use; nor for any infringement of patents or other rights of third parties which may result from its use.

Copies of this document are considered uncontrolled documents.

For the latest version of this document, visit our website:

[www.allegromicro.com](http://www.allegromicro.com)