

XTC7084H

**39.000000 MHz
TCXO**

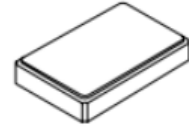

SM2016-6

Features:

- Ultra Miniature SMD Package
- Good Frequency Stability
- Good Phase Noise Response
- Moisture Sensitivity Level (MSL) : Level-1

Description and Applications:

Surface mount 2.0mmx1.6mm TCXO for use in wireless communications devices

Electrical Specifications:

XTC7084H	Specifications
Nominal Frequency, Fo	39.000000 MHz
Storage Temperature Range	-55°C to +125°C
Operating Temperature Range	-30°C to +85°C
Power Supply Voltage, Vcc	3.3 V+/-5%
Load	15pF(AC coupled)
Output	CMOS
"0" Level "1" Level	0.2 * Vcc max 0.8 * Vcc min
Power Supply Current, Icc	6.0 mA max
Duty Cycle	45% ~ 55%
Frequency Tolerance as Received Ref. to Nominal Frequency	+/- 1.0 ppm max @ 25°C +/- 3°C
Frequency Deviation after 2 x Reflow Ref. to pre-reflow Freq.	+/- 1.0 ppm max @ 25°C +/- 3°C
Frequency Stability a. Vs. Temperature (-30~85°C) b. Vs. Load varied 10pF//10KΩ+/-10% c. Vs. Supply Voltage varied Vcc+/-5%	+/- 2.0 ppm reference to 25°C +/- 0.2 ppm +/- 0.2 ppm
Start Up Time (90% of final RF level in Vp-p)	2.0 msec max.
Aging	+/-1.0 ppm/ first year @25°C
Phase Noise	-130 dBc/Hz Typ. at 1kHz offset

Enable/Disable Function (OE function)	PIN 1: $0.8 * V_{cc}$ min, PIN 3:Enable PIN 1: $0 \sim 0.2 * V_{cc}$, PIN 3:Disable PIN 1: Do not use in open condition
Marking	Laser marking



CAUTION: Electrostatic Sensitive Device. Observe precautions for handling.

NOTES:

1. The design, manufacturing process, and specifications of this device are subject to change.
2. US or International patents may apply.
3. This component was always RoHS compliant from the first date of manufacture.

Mechanical Dimensions (mm):

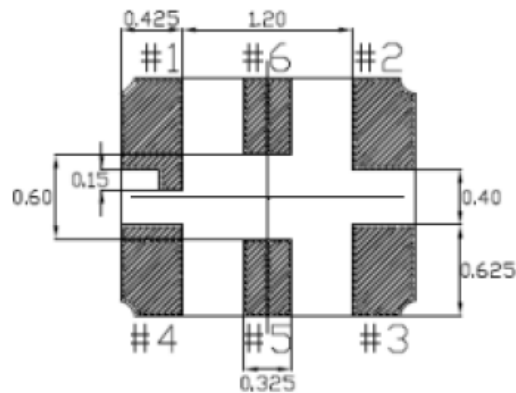
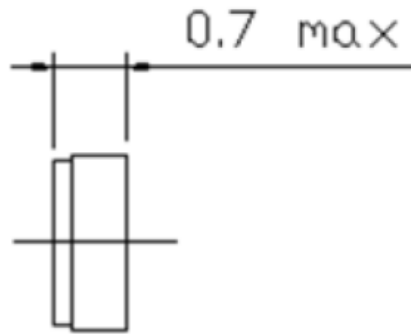
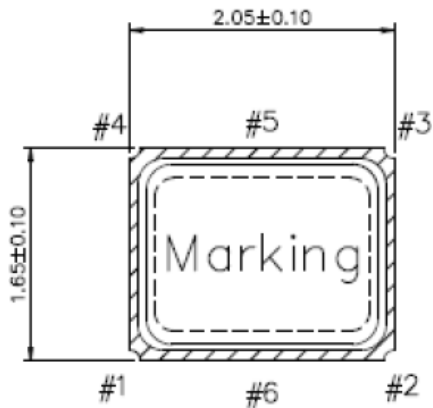

	Pin Connection
#1 pin	OE
#2 pin	GND
#3 pin	Output
#4 pin	+Vcc
#5 pin	No connect
#6 pin	No connect

Note: This package has two extra pads in the middle (pin #5 and #6) that are used to test the internal Xtal by the factory, but are not intended for customer use. Do not place ground (GND) patterns (including ground pads, via holes, etc.) under the crystal unit, especially under pin #5 and #6. Also, do not run RF signal, power or digital lines under the package in multi-layered PCB.

Recommended Land Pattern: (unit: mm)

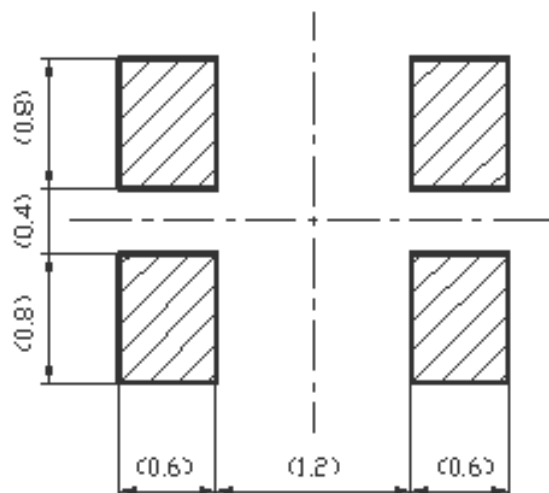

Marking:

Y = Year, W = week

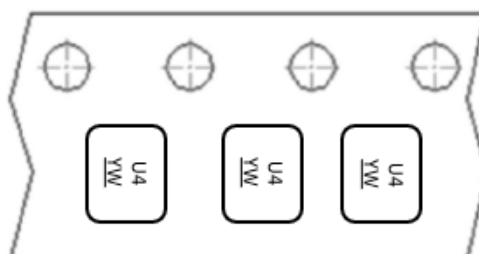

Recommended Circuit

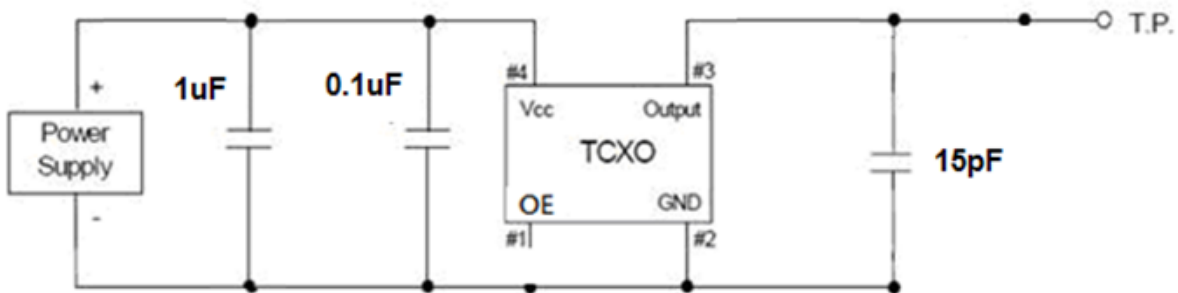

Reel Dimension

Reel Count:
7" = 3000

Tape and Reel Standard per ANSI/EIA-481

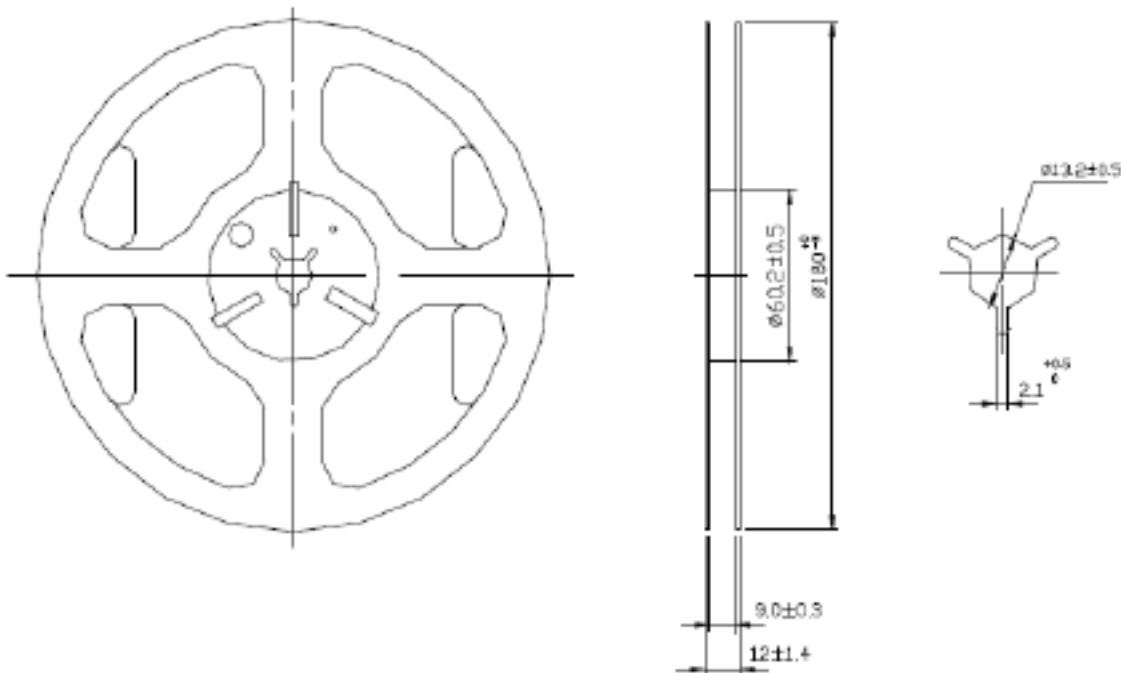

Tape Dimensions (mm)

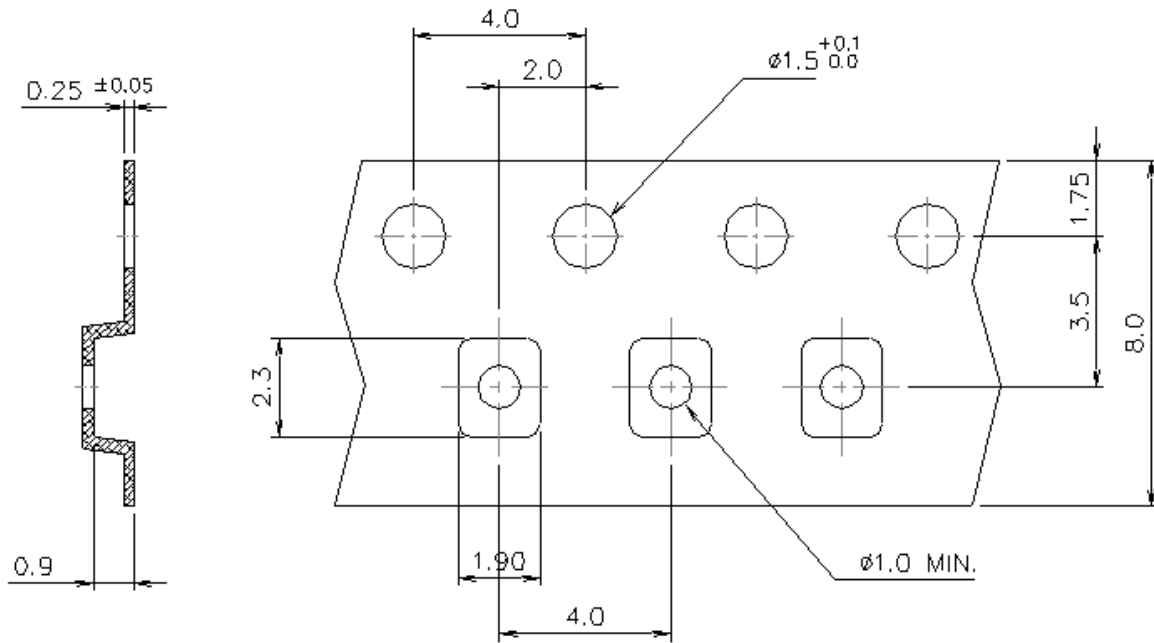

Packing Quantity/Packing:

3K pcs maximum per reel

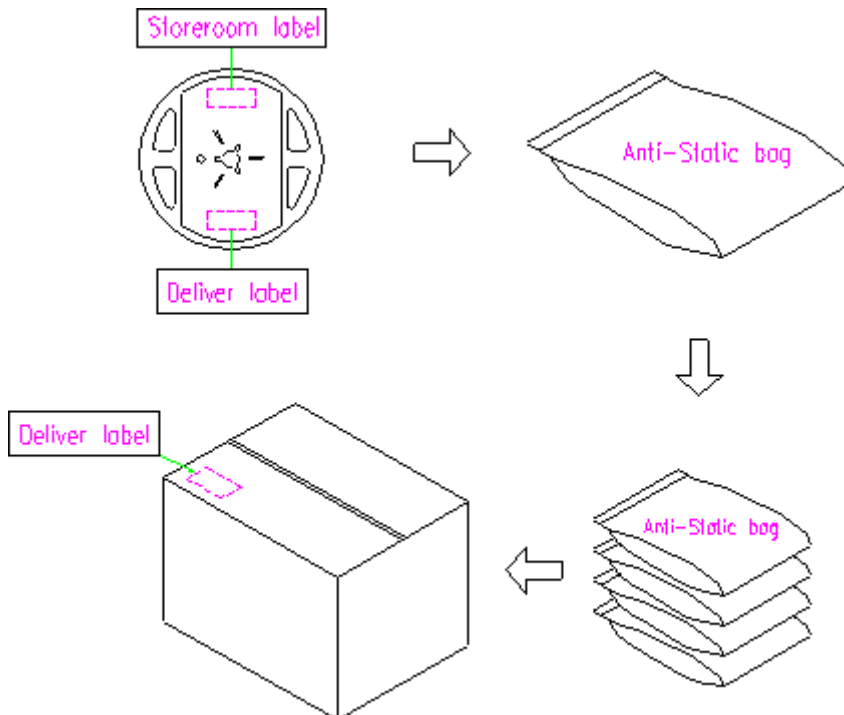

Reflow Profile:

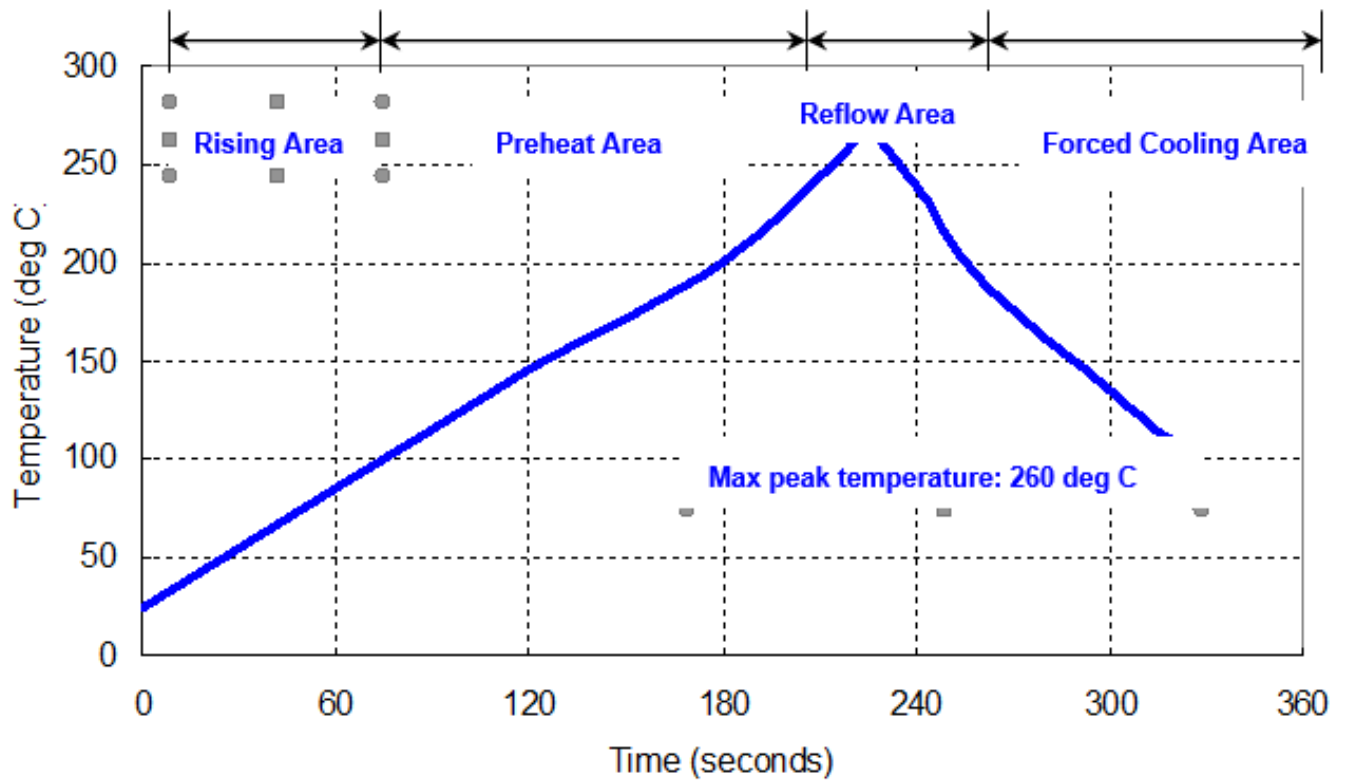

Notes of the Usage:

1. Touch the solder iron at 260 \pm 5 deg C onto the leads for 10 \pm 2 sec max or touch the solder at 350 \pm 5 deg C onto the leads for 3 \pm 0.5 sec.
2. In the customer's reflow process, if it will remain some mechanical stress at the soldering terminals, also make some cracks on the soldering termination. Some cracks will cause open or short circuit and cause of thermal increasing or smoking. Don't make any excess mechanical stress to soldering points.
3. In case of giving a heavy shock to the products, it may make an open or short circuit and cause of thermal increasing and smoking. To avoid heavy shock impact applying to products is strictly required.
4. Ultrasonic cleaning should be avoided to prevent damage to the TCXO.
5. Do Not Use Ultrasonic-Wave Soldering or Wave Solder with Package Immersed in Solder.
6. Do not lay out the ground (GND) pattern under crystal unit, this will add parasitic capacitance.
7. Do not run Digital / RF signal lines, power, or ground under oscillators for multi-layered PCB, as this will add noise.

Notes of the Storage:

1. To keep products under the condition at the room temperature (-5~35 deg C) with normal humidity (45~75%). Absorption of moisture and dewdrop may make inferiority of characteristics and a short circuit.
2. Oxidization of terminals shall make the solderability more inferior. Dusts and corrosive gas will make a cause of the open or short circuit. Keep it in the clean place where is not in dusty and no corrosive gas.
3. Use the anti-static material to the storage package.
4. Don't put any excess weight to the TCXO in the storage process.
5. Don't move the product from the cold place to the hot place in the short time, otherwise it may make some dew-drop, then a short circuit may happen in case.
6. Storage periods should be maximum 6 months under condition of above item 1 after delivery from the factory.
7. Once open the bag, there is possibility of electrical characteristics deterioration due to absorption of moisture. So, please use parts within 7 days after opening the bag.
8. If you have to keep parts without using after opening the bag, please put the drying agent in the bag, fold the bag and keep it in the place where temperature and humidity are controlled (nitrogen atmosphere box etc.)

Reliability Specifications

Test name	Test process / method	Reference standard
Mechanical characteristics		
resistance to Soldering heat (IR reflow)	Temp./ Duration : 265°C /10sec ×2 times Total time : 4min.(IR-reflow)	EIAJED-4701 -300(301)M(II)
Vibration	Total peak amplitude : 1.5mm Vibration frequency : 10 to 2000 Hz Sweep period : 20 minute Vibration directions : 3 mutually perpendicular Duration : 2 hr / direc.	MIL-STD 202G method 204
Mechanical Shock	directions : 3 impacts per axis Acceleration : 3000g's, +20/-0 % Duration : 0.3 ms (total 18 shocks) Waveform : Half-sine	MIL-STD 202G method 213
Solderability	Solder Temperature:265±5°C Duration time: 5±0.5 seconds.	J-STD-002
Environmental characteristics		
Thermal Shock	Heat cycle conditions -40 °C (30min) ↔ 85 °C (30min) * cycle time : 10 times	MIL-STD 883G method 1010.8
Humidity test	Temperature : 85 ± 2 °C Relative humidity : 85% Duration : 96 hours	MIL-STD 202G method 103
Dry heat (Aging test)	Temperature : 125 ± 2 °C Duration : 168 hours	MIL-STD 202G method 108A
Cold resistance (Low Temp Storage)	Temperature : -40 ± 2 °C Duration : 96 hours	IEC 60068-2-1