

SF2259H

**921.5 MHz
SAW Filter**

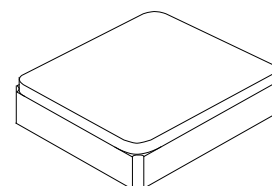

SM2016-4

- RF SAW Filter, 921.5 MHz, 13 MHz Bandwidth
- 2.0 x 1.6 x 0.9 mm Surface-mount Case
- Input/Output Impedance 50Ω/50Ω
- Complies with Directive 2002/95/EC (RoHS)
- Moisture Sensitivity Level: 1
- AEC-Q200 Qualified

Absolute Maximum Ratings

Rating	Value	Units
Maximum Incident Power in Passband	+15	dBm
Maximum DC Voltage on any Non-ground Terminal	3	VDC
Operating Temperature Range	-40 to +85	°C
Storage Temperature Range in Tape and Reel	-40 to +85	°C
Maximum Soldering Profile, 5 Cycles	265 °C for 10 s	

Electrical Characteristics

Characteristic	Sym	Notes	Min	Typ	Max	Units
Center Frequency	f_C			921.5		MHz
Maximum Insertion Loss, 915 - 928 MHz	IL_{MAX}			2.0	3.0	dB
Amplitude Ripple, p-p, 915 - 928 MHz				0.3	1.0	
Return Loss, 915 - 928 MHz			10	12		ns
Group Delay Ripple, 915 - 928 MHz				15	50	
Attenuation, Referenced to 0 dB:						dB
10 to 857.5 MHz			40	52		
857.5 to 895 MHz			22	45		
970 to 1005 MHz			35	40		
1005 to 1110 MHz			40	56		
1110 to 3000 MHz			30	39		
Terminating Source impedance	Z_S			50		Ω
Terminating Load impedance	Z_L			50		Ω
Single Ended Input / Output, Impedance match	No matching network required for operation at 50 ohms					
Case Style	SM2016-4					
Lid Symbolization: Y = Year, W = Week)	3W, <u>YW</u>					

 **CAUTION: Electrostatic Sensitive Device. Observe precautions for handling.**

NOTES:

1. The design, manufacturing process, and specifications of this device are subject to change.
2. US or International patents may apply.
3. RoHS compliant from the first date of manufacture.

Matching Circuit

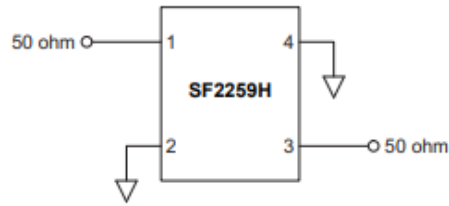

Frequency Response Plots

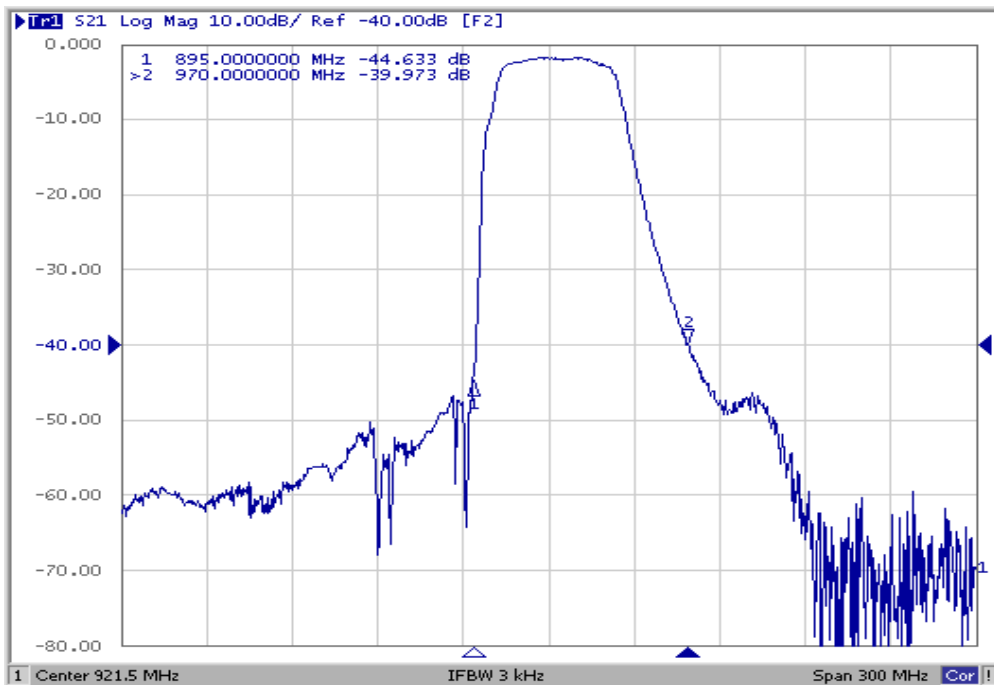
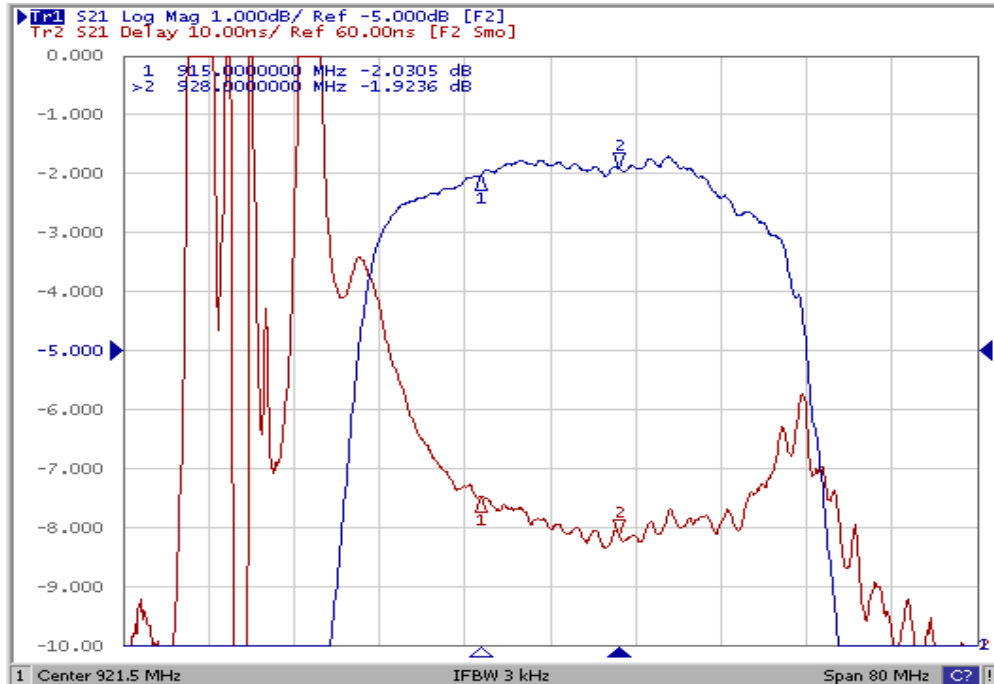

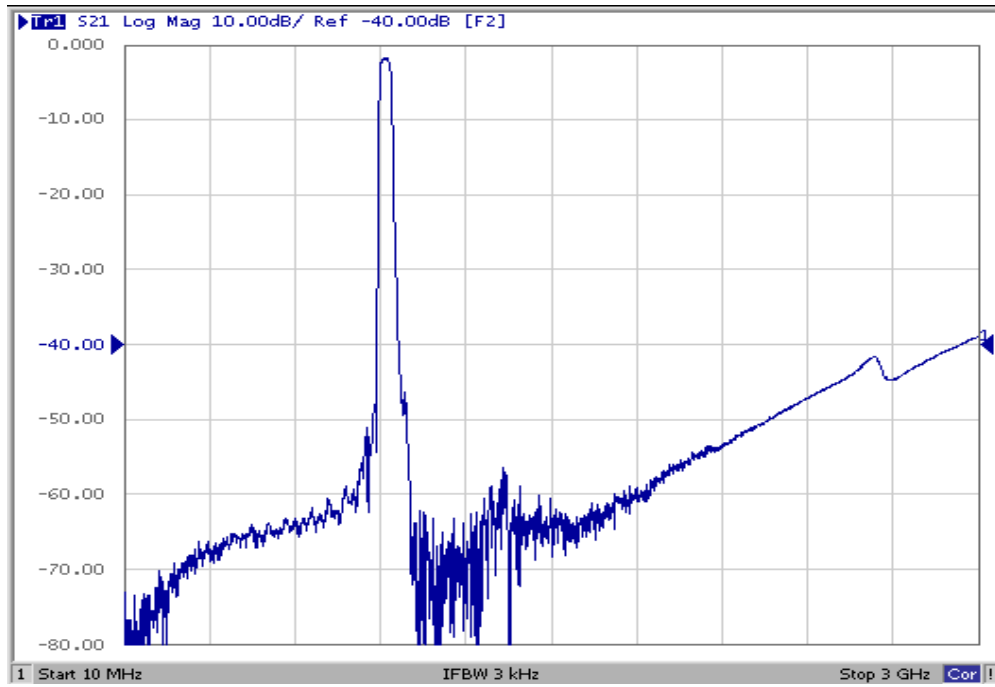

Return Loss Plots

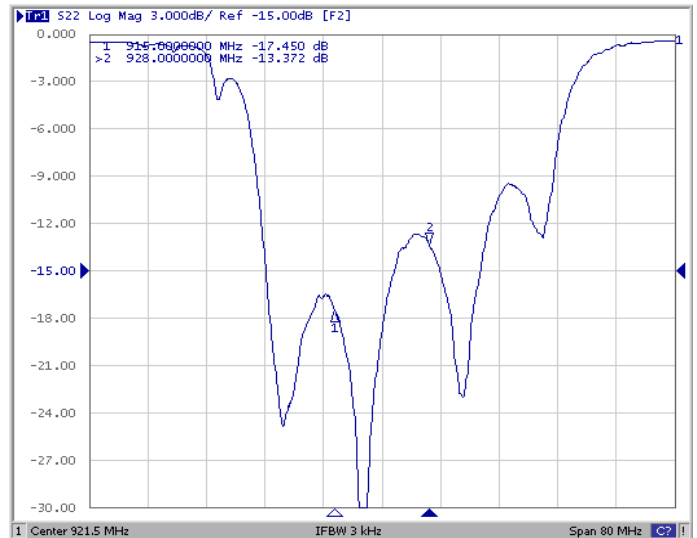
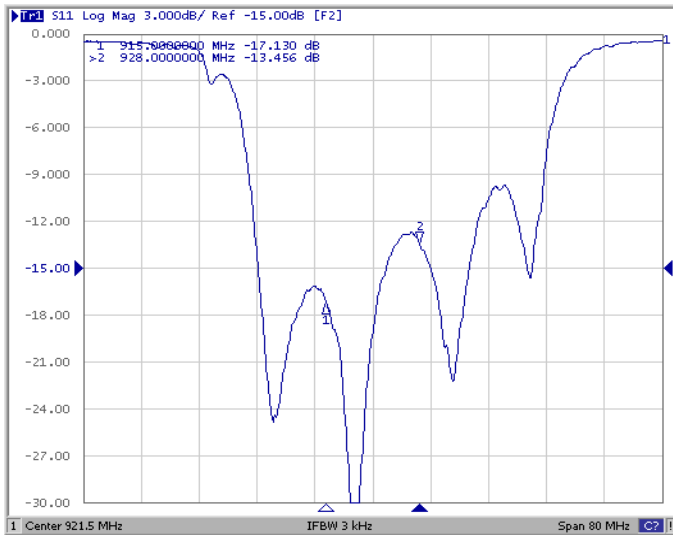

SM2016-4 Case

4-Terminal Ceramic Surface-Mount Case

2.0 X 1.6 mm Nominal Footprint

Case Dimensions

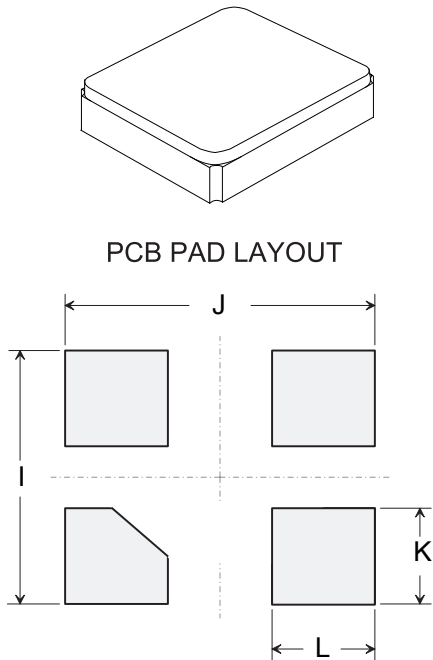

Dimensions in mm
All pads have the same dimensions

Dimension	mm		
	Min	Nom	Max
A	1.57	1.60	1.73
B	1.97	2.00	2.13
C	0.55	0.65	0.75
D	-	0.10	-
E	-	0.10	-
F	-	0.70	-
G	-	0.50	-
H	-	0.10	-
I	-	1.80	-
J	-	2.20	-
K	-	0.60	-
L	-	0.80	-

Materials	
Solder Pad Plating	0.3 to 1.0 μm Gold over 1.27 to 8.89 μm Nickel
Lid Plating	2.0 to 3.0 μm Nickel
Body	Al_2O_3 Ceramic

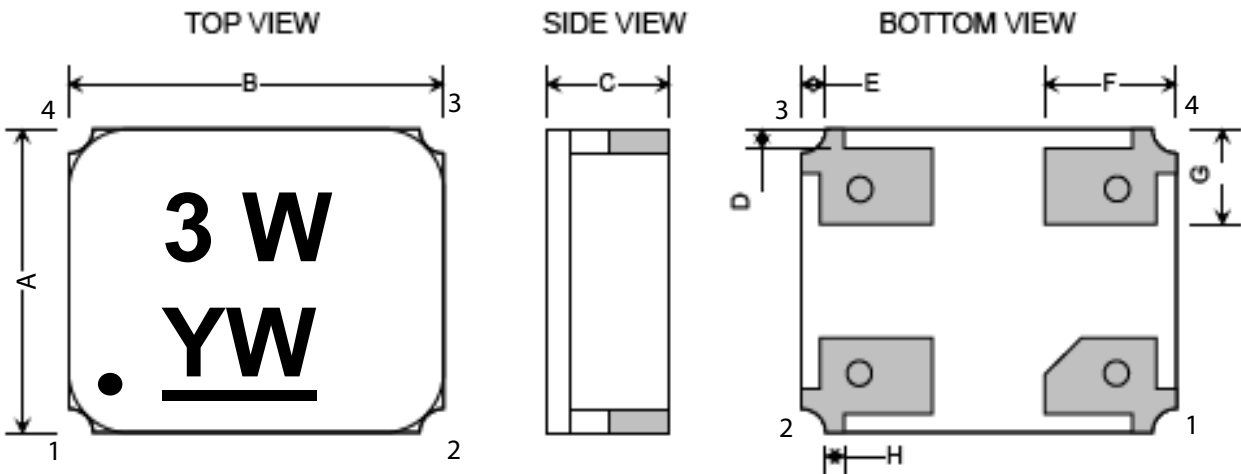

Recommended Reflow Profile

1. Preheating shall be fixed at 150~180°C for 60~90 seconds.
2. Ascending time to preheating temperature 150°C shall be 30 seconds min.
3. Heating shall be fixed at 220°C for 50~80 seconds and at 260°C +0/-5°C peak (10 seconds).
4. Time: 5 times maximum.

