

- **Designed for 868.95 MHz SRD Transmitters**
- **Very Low Series Resistance**
- **Quartz Stability**
- **Complies with Directive 2002/95/EC (RoHS)**
- **Tape and Reel Standard per ANSI/EIA-481**
- **Moisture Sensitivity Level: 1**
- **AEC-Q200 Qualified**

RO3156D

**868.95 MHz
SAW Resonator**

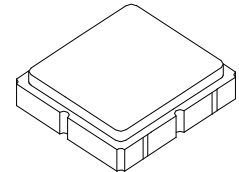

**SM3838-6 Case
3.8 X 3.8**

The RO3156D is a true one-port, surface-acoustic-wave (SAW) resonator in a surface-mount ceramic case. It provides reliable, fundamental-mode stabilization of fixed-frequency transmitters operating at 868.95 MHz. This SAW is designed specifically for SRD remote control and security transmitters operating under ETSI EN 300 220 regulations.

Absolute Maximum Ratings

Rating	Value	Units
Input Power Level	10	dBm
DC Voltage	12	VDC
Storage Temperature	-40 to +85	°C
Soldering Temperature, 10 seconds / 5 cycles maximum	260	°C

Electrical Characteristics

Characteristic	Sym	Notes	Minimum	Typical	Maximum	Units
Frequency, +25 °C	f_c		868.750		869.150	MHz
Tolerance from 916.5 MHz	Δf_c				±200	kHz
Insertion Loss	IL			1.20	2.5	dB
Quality Factor	Unloaded Q	Q_U		6300		
	50 Ω Loaded Q	Q_L		850		
Temperature Stability	Turnover Temperature	T_O	10	25	40	°C
	Turnover Frequency	f_O		f_c		MHz
	Frequency Temperature Coefficient	FTC		0.032		ppm/°C ²
Frequency Aging	Absolute Value during the First Year	fA		10		ppm
DC Insulation Resistance between Any Two Terminals			1.0			M Ω
RF Equivalent RLC Model	Motional Resistance	R_M		15.7		Ω
	Motional Inductance	L_M		18.1		μ H
	Motional Capacitance	C_M		1.85		fF
	Transducer Static Capacitance	C_O		2.2		pF
Test Fixture Shunt Inductance	L_{TEST}			15.2		nH
Lid Symbolization: Y = Year, WW = Week, S = Shift				715, YWWS		
Standard Reel Quantity	Reel Size 7 Inch			500 Pieces / Reel		
	Reel Size 13 Inch			3000 Pieces / Reel		



CAUTION: Electrostatic Sensitive Device. Observe precautions for handling.

NOTES:

1. The design, manufacturing process, and specifications of this device are subject to change.
2. US or International patents may apply.
3. RoHS compliant from the first date of manufacture.

Electrical Connections

The SAW resonator is bidirectional and may be installed with either orientation. The two terminals are interchangeable and unnumbered. The call out NC indicates no internal connection. The NC pads assist with mechanical positioning and stability. External grounding of the NC pads is recommended to help reduce parasitic capacitance in the circuit.

Pin	Connection
1	NC
2	Terminal
3	NC
4	NC
5	NC
6	Terminal
7	NC
8	NC

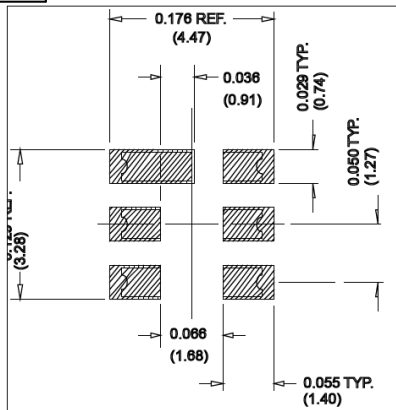
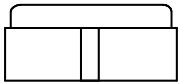
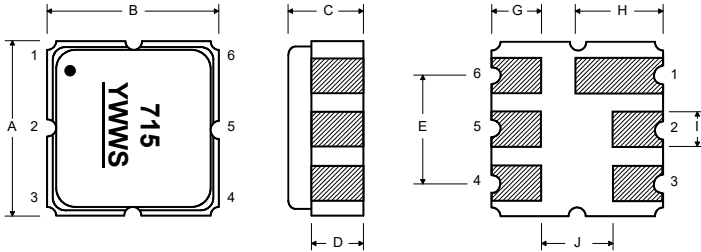

Case Dimensions

Dimension	mm			Inches		
	Min	Nom	Max	Min	Nom	Max
A	3.60	3.80	4.00	0.142	0.150	0.157
B	3.60	3.80	4.00	0.142	0.150	0.157
C	1.10	1.30	1.50	0.043	0.050	0.060
D	0.95	1.10	1.25	0.037	0.043	0.049
E	2.39	2.54	2.69	0.094	0.100	0.106
G	0.90	1.00	1.10	0.035	0.040	0.043
H	1.90	2.00	2.10	0.748	0.079	0.083
I	0.50	0.60	0.70	0.020	0.024	0.028
J	1.70	1.80	1.90	0.067	0.071	0.075

Equivalent RLC Model

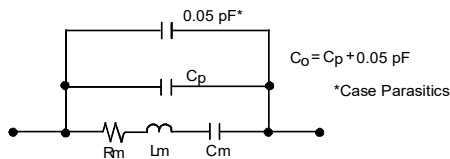

Parameter Test Circuit

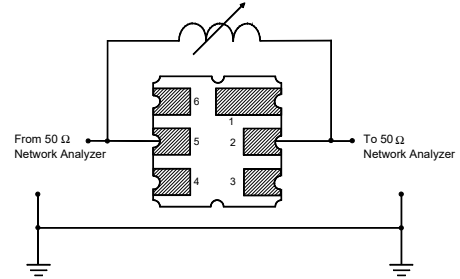

Power Test Circuit

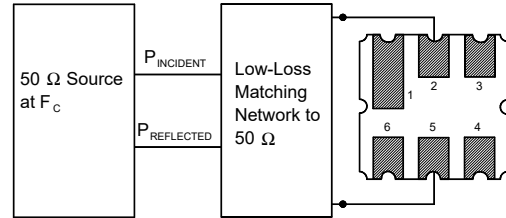

Example Application Circuits

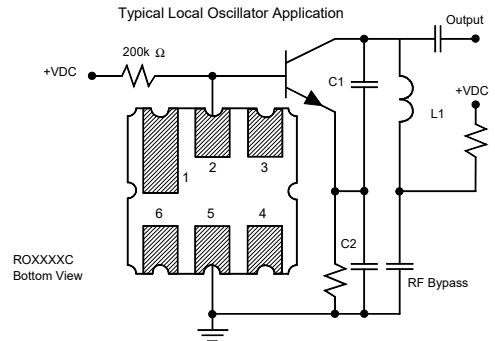
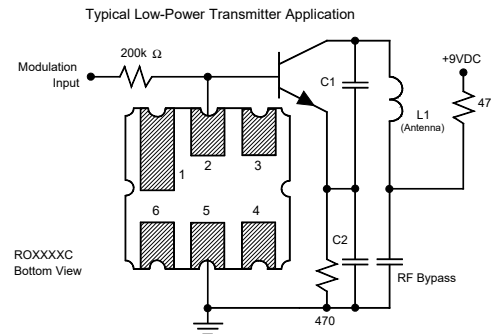

Temperature Characteristics

The curve shown on the right accounts for resonator contribution only and does not include LC component temperature contributions.

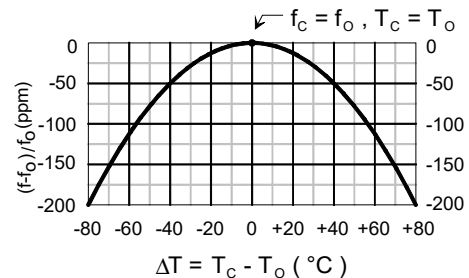

Recommended Reflow Profile

1. Preheating shall be fixed at 150~180°C for 60~90 seconds.
2. Ascending time to preheating temperature 150°C shall be 30 seconds min.
3. Heating shall be fixed at 220°C for 50~80 seconds and at 260°C +0/-5°C peak (10 seconds).
4. Time: 5 times maximum.

