

**RO3150E**

**304 MHz  
SAW Resonator**

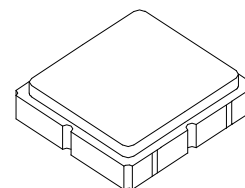

**SM3030-6 Case**

- **Designed for Low Power 304 MHz Transmitters**
- **Very Low Series Resistance**
- **Quartz Frequency Stability**
- **Miniature 3.0 x 3.0 mm Surface-mount Case**
- **Complies with Directive 2002/95/EC (RoHS)**
- **Tape and Reel Standard per ANSI/EIA-481**
- **Moisture Sensitivity Level: 1**

The RO3104E is a true one-port, surface-acoustic-wave (SAW) resonator in a surface-mount ceramic case. It provides reliable, fundamental-mode quartz frequency stabilization of fixed-frequency transmitters operating at 304 MHz. This SAW is designed specifically for transmitters used in wireless security and remote control applications.

**Absolute Maximum Ratings**

Rating	Value	Units
CW RF Power Dissipation (See Typical Test Circuit)	0	dBm
DC Voltage Between Terminals (Observe ESD Precautions)	5	VDC
Case Temperature	-40 to +85	°C
Maximum Soldering Profile Temperature (10 s, 5 cycles maximum)	+260	°C

**Electrical Characteristics**

Characteristic		Sym	Notes	Minimum	Typical	Maximum	Units
Frequency, +25 °C	Nominal Frequency	$f_C$		303.925	304.000	304.075	MHz
	Tolerance from 304.000 MHz	$\Delta f_C$				$\pm 75$	kHz
Insertion Loss		IL			1.35	2.0	dB
Quality Factor	Unloaded Q	$Q_U$			14,590		
	50 $\Omega$ Loaded Q	$Q_L$			2,100		
Temperature Stability	Turnover Temperature	$T_O$		10	25	40	°C
	Turnover Frequency	$f_O$			$f_C$		
	Frequency Temperature Coefficient	FTC			0.032		ppm/°C <sup>2</sup>
Frequency Aging	Absolute Value during the First Year	$ f_A $			10		ppm/yr
DC Insulation Resistance between Any Two Terminals				1.0			M $\Omega$
RF Equivalent RLC Model	Motional Resistance	$R_M$			16		$\Omega$
	Motional Inductance	$L_M$			125		$\mu$ H
	Motional Capacitance	$C_M$			2.1		fF
	Transducer Static Capacitance	$C_O$			3.8		pF
Test Fixture Shunt Inductance		$L_{TEST}$			TBD		nH
Lid Symbolization: Y - Year, WW = Week, S = Shift				977, <u>YWWS</u>			
Standard Reel Quantity	Reel Size 7 Inch			500 Pieces/Reel			
	Reel Size 13 Inch			3000 Pieces/Reel			



**CAUTION: Electrostatic Sensitive Device. Observe precautions for handling.**

**NOTES:**

1. The design, manufacturing process, and specifications of this device are subject to change.
2. US or International patents may apply.
3. RoHS compliant from the first date of manufacture.

**Electrical Connections**

The SAW resonator is bidirectional and may be installed with either orientation. The two terminals are interchangeable and unnumbered. The callout NC indicates no internal connection. The NC pads assist with mechanical positioning and stability. External grounding of the NC pads is recommended to help reduce parasitic capacitance in the circuit.

Pin	Connection
1	NC
2	Terminal
3	NC
4	NC
5	Terminal
6	NC

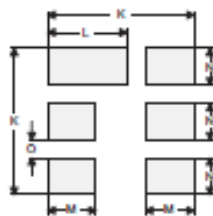
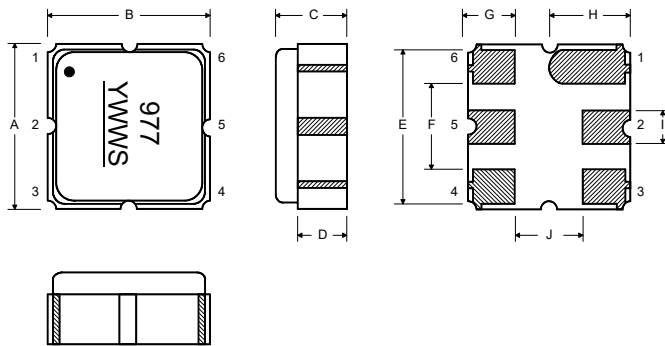

**Temperature Characteristics**

The curve shown accounts for resonator contribution only and does not include external LC component temperature effects.

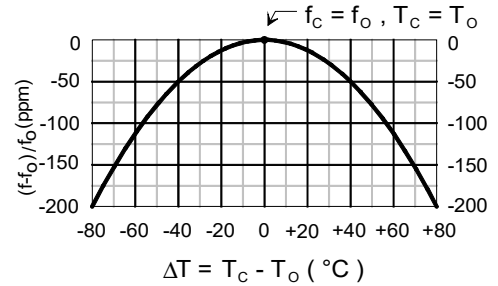

**Characterization Test Circuit**

Inductor  $L_{TEST}$  is tuned to resonate with the static capacitance,  $C_0$ , at  $F_C$ .

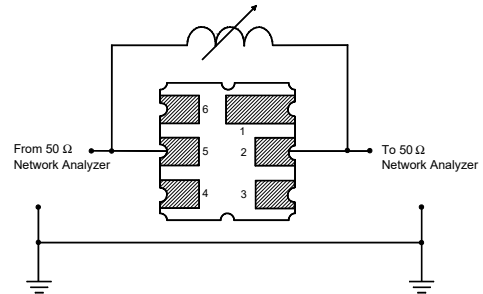

**Power Dissipation Test**

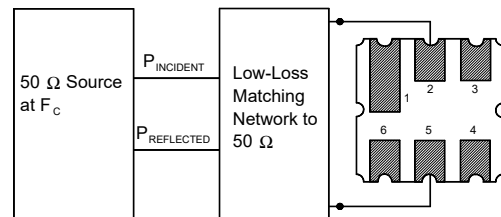

## Case and Typical PCB Land Dimensions

Ref	mm			Inches		
	Min	Nom	Max	Min	Nom	Max
A	2.87	3.00	3.13	0.113	0.118	0.123
B	2.87	3.00	3.13	0.113	0.118	0.123
C	1.12	1.25	1.38	0.044	0.049	0.054
D	0.77	0.90	1.03	0.030	0.035	0.040
E	2.67	2.80	2.93	0.105	0.110	0.115
F	1.47	1.60	1.73	0.058	0.063	0.068
G	0.72	0.85	0.98	0.028	0.033	0.038
H	1.37	1.50	1.63	0.054	0.059	0.064
I	0.47	0.60	0.73	0.019	0.024	0.029
J	1.17	1.30	1.43	0.046	0.051	0.056
K		3.20			0.126	
L		1.70			0.067	
M		1.05			0.041	
N		0.81			0.032	
O		0.38			0.015	

## Example Application Circuits

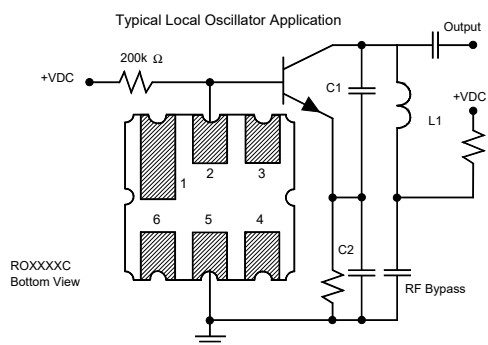
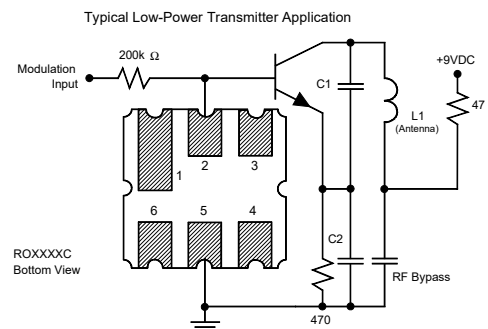

## Equivalent RLC Model

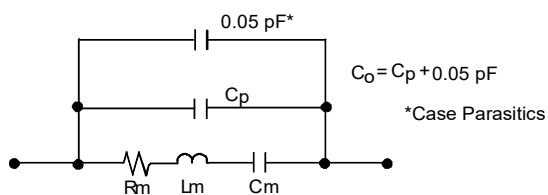

## Recommended Reflow Profile

1. Preheating shall be fixed at 150~180°C for 60~90 seconds.
2. Ascending time to preheating temperature 150°C shall be 30 seconds min.
3. Heating shall be fixed at 220°C for 50~80 seconds and at 260°C +0/-5°C peak (10 seconds).
4. Time: 5 times maximum.

