

RF1439E

**315.00 MHz
SAW Filter**

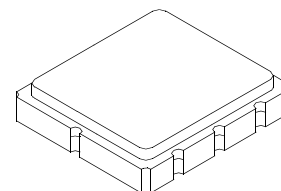

**SM3030-6 Case
3.0 x 3.0**

- **Ideal Front-End Filter for Wireless Receivers**
- **Low-Loss, Coupled-Resonator Quartz Design**
- **Simple Impedance Matching**
- **Complies with Directive 2002/95/EC (RoHS)**
- **Moisture Sensitivity Level: 1**

The RF1439E is a low-loss, compact, and economical surface-acoustic-wave (SAW) filter designed to provide front-end selectivity in 315.0 MHz receivers. Receivers using this filter include superheterodynes with IF's at 10.7 MHz or 500 kHz, plus direct conversion and superregeneratives. Typical applications of these receivers are wireless remote-control and security devices operating in North America. This coupled-resonator filter (CRF) uses selective null placement to provide typically more than 40 dB suppression of LO and image responses in superheterodyne receivers with 10.7 MHz IF's. RFMi's advanced SAW design and fabrication technology is utilized to achieve high performance and very low loss with simple external impedance matching.

Electrical Characteristics

Characteristic	Sym	Notes	Minimum	Typical	Maximum	Units
Center Frequency @ 25°C	f_c		314.900	315.00	315.100	MHz
Insertion Loss	IL			2.0	2.5	dB
3 dB Bandwidth	BW_3		850	900	950	kHz
Passband Ripple (Relative to IL_{min}) $f_c \pm 200$ kHz	BW_3			0.4	1.2	dB
Rejection	10 - 297 MHz		48	51		dB
	297 - 307 MHz		40	44		
	307 - 312 MHz		30	34		
	312 - 314 MHz		13	16		
	316.5 - 325 MHz		14	17		
	325 - 329.5 MHz		35	38		
	329.5 - 339.4 MHz		43	46		
339.4 - 1000 MHz		47	50			
Frequency Temperature Coefficient	FTC			0.032		ppm/°C ²
Frequency Aging	Absolute Value during the First Year	fA		<±10		ppm/yr
Impedance @ f_c	Input $Z_{IN} = R_{IN} \parallel C_{IN}$	Z_{IN}	TBD			
	Output $Z_{OUT} = R_{OUT} \parallel C_{OUT}$	Z_{OUT}	TBD			
Lid Symbolization (Y = Year, WW = Week, S = Shift)			793, <u>YWWS</u>			
Standard Reel Quantity	7 Inch Reel			500 Pieces/Reel		
Standard Reel Quantity	13 Inch Reel			3000 Pieces/Reel		



CAUTION: Electrostatic Sensitive Device. Observe precautions for handling.

NOTES:

1. The design, manufacturing process, and specifications of this device are subject to change.
2. US or International patents may apply.
3. RoHS compliant from the first date of manufacture.

RF1439E Filter Plot with High-Side Attenuation Markers

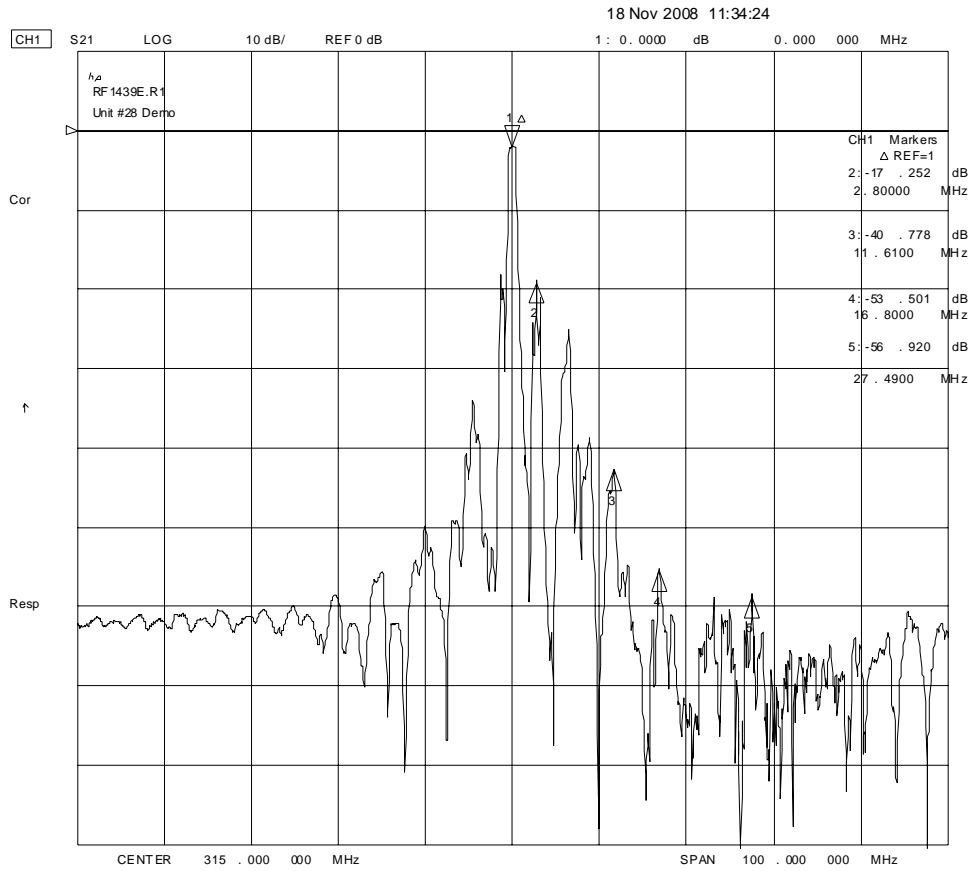

RF1439E Filter Plot with Low-Side Attenuation Markers

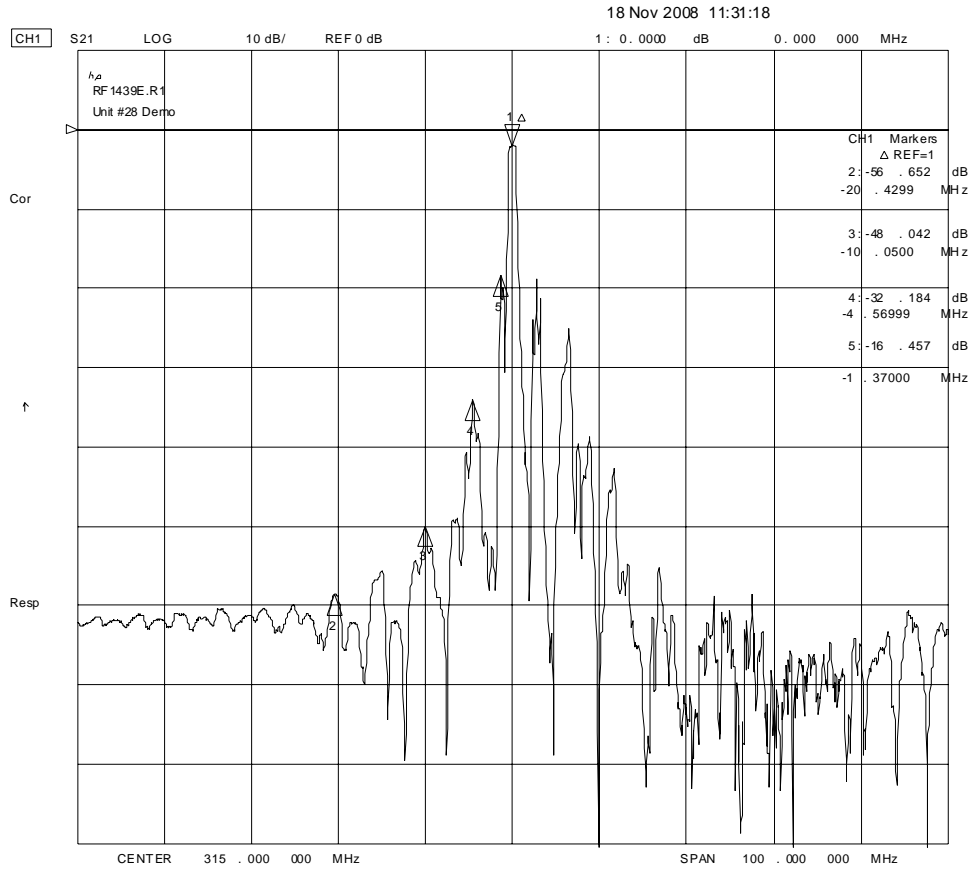

RF1439E Filter Pass-band Impedance and Amplitude Plots

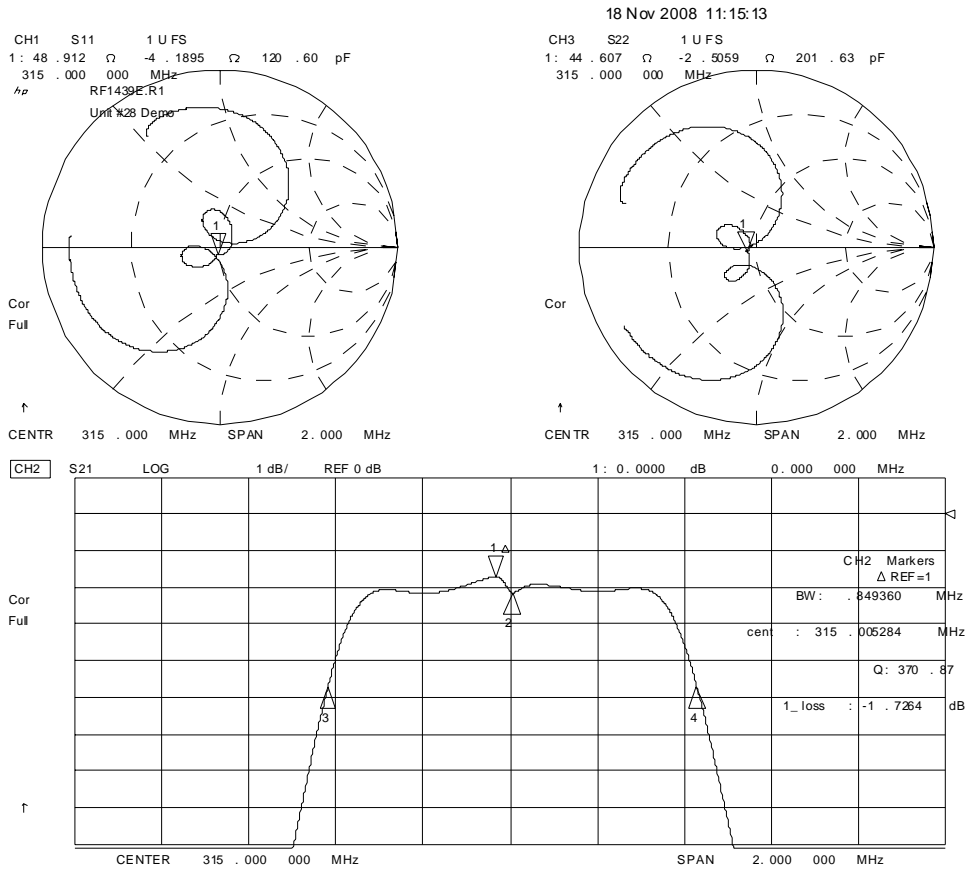

Absolute Maximum Ratings

Rating	Value	Units	
Input Power Level	10	dBm	
DC Voltage	12	VDC	
Storage Temperature	-40 to +125	°C	
Operable Temperature Range	-40 to +125	°C	
Soldering Temperature	10 seconds / 5 cycles maximum	260	°C

Electrical Connections

Pin	Connection
1	Input
2	Input Ground
3	Ground
4	Output
5	Output Ground
6	Ground

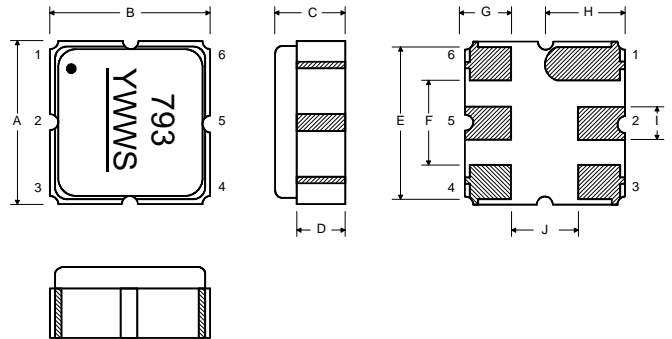

Matching Circuit to 50Ω

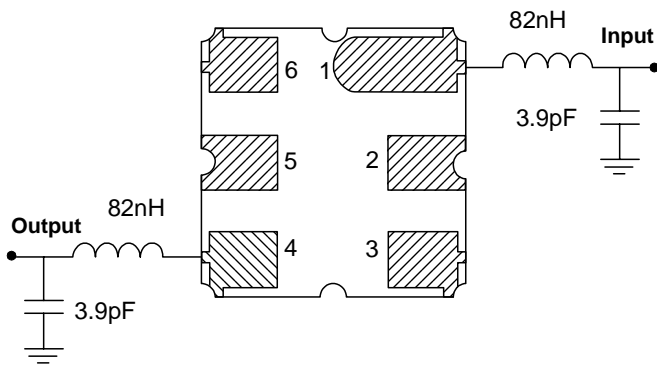

Case Dimensions

Dimension	mm			Inches		
	Min	Nom	Max	Min	Nom	Max
A	2.87	3.0	3.13	0.113	0.118	0.123
B	2.87	3.0	3.13	0.113	0.118	0.123
C	1.12	1.25	1.38	0.044	0.049	0.054
D	0.77	0.90	1.03	0.030	0.035	0.040
E	2.67	2.80	2.93	0.105	0.110	0.115
F	1.47	1.6	1.73	0.058	0.063	0.068
G	0.72	0.85	0.98	0.028	0.033	0.038
H	1.37	1.5	1.63	0.054	0.059	0.064
I	0.47	0.60	0.73	0.019	0.024	0.029
J	1.17	1.30	1.43	0.046	0.051	0.056

Recommended Reflow Profile

1. Preheating shall be fixed at 150~180°C for 60~90 seconds.
2. Ascending time to preheating temperature 150°C shall be 30 seconds min.
3. Heating shall be fixed at 220°C for 50~80 seconds and at 260°C +0/-5°C peak (10 seconds).
4. Time: 5 times maximum.

