

IS31BL3506A BOOST CONVERTER LED BACKLIGHT DRIVER

DESCRIPTION

IS31BL3506A LED driver demo board is used to demonstrate and evaluate the IS31FL3506A. IS31BL3506A is a boost converter featuring an integrated MOSFET switch designed for driving series strings of LED or other device. The device regulates the LED load current is set using an external, low value sensing resistor. The device adjusts the PWM duty cycle of the switch to maintain the voltage at the FB pin at a value of 0.3V.

FEATURES

- Supply voltage: 2.7V~5.5V
- Drive series strings of 9 LEDs
- PWM or DC voltage dimming
- Frequency of PWM is 500Hz ~ 500kHz
- 1.0MHz high speed switching frequency
- DFN-8 (2mm×2mm) package

QUICK START

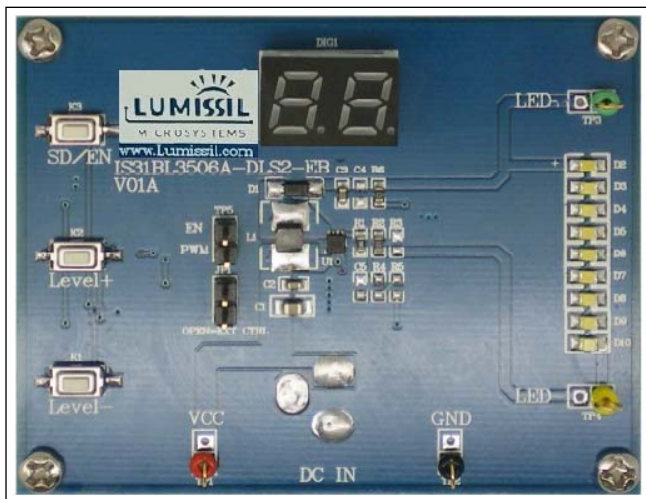

Figure 1 Photo of IS31BL3506A Evaluation Board

RECOMMENDED EQUIPMENT

- 5.0V, 2A power supply

ABSOLUTE MAXIMUM RATINGS

- $\leq 5.5V$ power supply

Caution: Do not exceed the conditions listed above, otherwise the board will be damaged.

PROCEDURE

The IS31BL3506A evaluation board is fully assembled and tested. Follow the below steps to verify operation.

Caution: Do not turn on the power supply until all connections are completed.

- 1) Connect the ground terminal of the power supply to the GND and the positive terminal to the VCC. Or connect the DC power to the connector (DC IN).
- 2) Turn on the power supply and pay attention to the supply current. If the current exceeds 500mA, please check for circuit fault.
- 3) Press Level+ or Level- button to change current of white LEDs, the intensity of LEDs will be in 1 level (lowest) when power on.
- 4) The button (SD/EN) controls the IS31BL3506A Shutdown or Enable.

EVALUATION BOARD OPERATION

The IS31BL3506A evaluation board performs constant output current with PWM dimming control.

The evaluation board uses a MCU generating PWM signal at EN pin adjusting the LEDs current. The current level is displayed by Dual Digit Display.

Note: IS31BL3506A solely controls the white LEDs function on the evaluation board.

SOFTWARE SUPPORT

JP1 is set to close circuit by default. If it is set to open, the onboard MCU will stop working. The MCU pin which drives the EN pin of the LED driver will be set to High Impedance. An external driving signal can be connected to the TP5 connecting point to control the IS31BL3506A LED driver.

Please refer to the datasheet to get more information about IS31BL3506A.

IS31BL3506A BOOST CONVERTER LED BACKLIGHT DRIVER

ORDERING INFORMATION

Part No.	Temperature Range	Package
IS31BL3506A-DLS2-EB	-40°C ~ +85°C (Industrial)	DFN-8, Lead-free

Table1 Ordering Information

For pricing, delivery, and ordering information, please contact Lumissil's analog marketing team at analog@lumissil.com or (408) 969-6600.

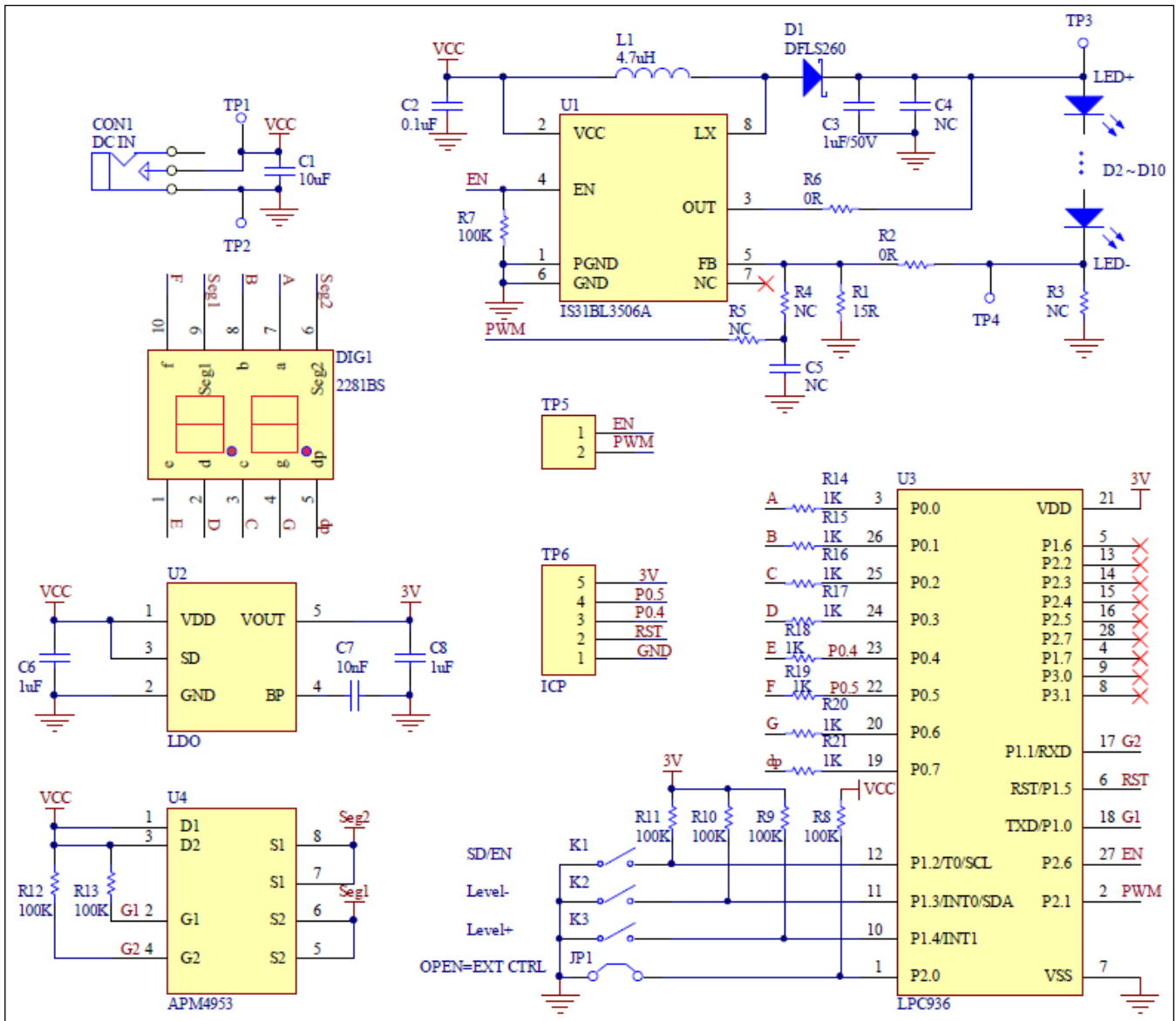

Figure 2 IS31BL3506A Application Schematic

IS31BL3506A BOOST CONVERTER LED BACKLIGHT DRIVER

BILL OF MATERIALS

Name	Symbol	Description	Qty	Supplier	Part No.
LED Driver	U1	Boost converter LED driver	1	Lumissil	IS31BL3506A
LDO	U2	Low-dropout regulator	1	PAM	PAM3101
MCU	U3	Microcontroller	1	NXP	LPC936
PMOS	U4	Dual PMOS	1	ANPEC	APM4953
Display	DIG1	Dual digit display common anode	1	ZSO	2281BS
Diode	D1	Schottky Diode, SMD	1		DFLS260
Diode	D2~D10	Diode, LED White, SMD	9	Everlight	EHP-C04/UT01-P01/TR
Inductor	L1	IND,4.7 μ H \pm 20%,SMD	1	Microgate	4.7 μ H,IND
Resistor	R1	RES,15R,1/16W, \pm 5%,SMD	1		
Resistor	R2,R6	RES,0R,1/16W, \pm 5%,SMD	2		
	R3,R4,R5,C4,C5	Not Connect	5		
Resistor	R7~R13	RES,100k,1/16W, \pm 5%,SMD	7		
Resistor	R14~R21	RES,1k,1/16W, \pm 5%,SMD	8		
Capacitor	C1	CAP,10 μ F,16V, \pm 20%,SMD	1		
Capacitor	C2	CAP,0.1 μ F,16V, \pm 20%,SMD	1		
Capacitor	C3,C6,C8	CAP,1 μ F,50V, \pm 20%,SMD	3		
Capacitor	C7	CAP,10nF,16V, \pm 20%,SMD	1		
Buttons	K1~K3	Buttons SMD	3		

Bill of materials, refer to Figure 2 above.

IS31BL3506A BOOST CONVERTER LED BACKLIGHT DRIVER

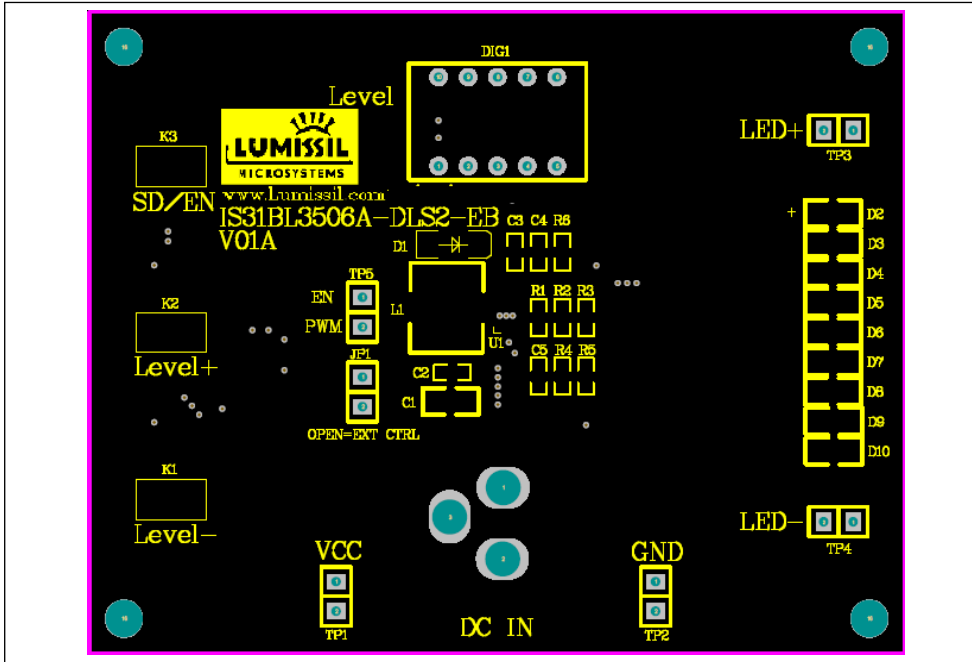

Figure 3 Board Component Placement Guide -Top Layer

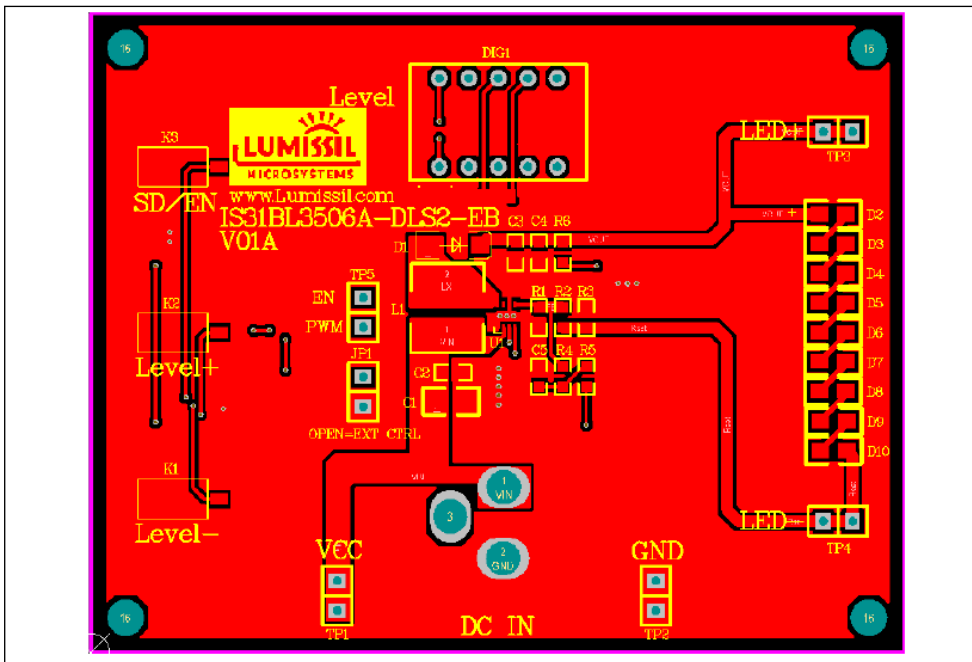

Figure 4 Board PCB Layout- Top Layer



REVISION HISTORY

Revision	Detail Information	Date
A	Initial release	2012.07.12
B	Update to new Lumissil logo	2025.11.10