

# EM630



## Energy meter for single phase, two phase and three phase systems



### Description

EM630 is an energy analyser connected through 5 A current transformers or 333 mV current sensors, for three phase, two phase and single phase systems up to 480 V L-L. Modbus TCP/IP and HTTPS rest API communication are available via Ethernet port and/or Wi-Fi. According to the model, a digital input combined with digital output, a Modbus RTU or an M-Bus port are available thanks to additional patented sliding module. W versions also feature Wi-Fi connection and RTC synchronization.

### Benefits

- **Quick configuration.** The configuration wizard which runs when the system is started up for the first time allows you to commission the unit without errors in a matter of seconds. The UCS configuration software is available for download free of charge. The embedded Webserver makes the configuration even easier and faster (W versions only).
- **User-friendly interface.** The 128x96 matrix LCD with backlit display ensures perfect visibility and readability of the information. Page configuration and browsing are very intuitive, thanks to the user interface with 3 mechanical keys. Finally, the page filter allows you to hide the unnecessary information.
- **Flexible installation.** It can be installed in Single-phase, two-phase and three-phase (with and without neutral). It also permits the monitoring of 3 loads in single-phase systems.
- **Robust design.** Able to work in an extremely wide temperature range, up to 70 °C / 158 °F, thanks to the temperature drift compensation and up to 3000 m / 9842.5 ft altitude.
- **Multi-interface communication.** EM630 is able to transmit and receive data through Modbus TCP/IP or HTTPS rest API via Ethernet or Wi-Fi. In addition, Modbus RTU or M-Bus are optionally available.
- **Fiscal and revenue grade metrology.** EM630 is the perfect solution for fiscal metrology; in fact, the product conforms with the most important European and American standards for fiscal metrology: ANSI and MID regulation.
- **Real-time synchronization.** Clock and datalogging. Thanks to the real time clock and the internal memory, EM630 guarantees log of energy consumption/production up to two years.

### Applications

EM630 can be installed in any low-voltage switchboard, to monitor the energy consumption, the main electrical variables and the harmonic distortion. Compatible with any current transformer with 5 A secondary current, it can be installed in systems with rated current up to 10 kA, even in retrofit applications if used with openable transformers like CTA, CTD S or CTVs.

If used to monitor a single machine, it provides all the main electrical variables to identify any possible malfunction in its early stage and can correlate the energy consumption with the hours of operation, to plan maintenance and prevent failures. The partial meter reset function, easily implementable by means of a digital input, allows you to monitor each individual machine cycle.

Thanks to the measurement refresh time (100 ms) and to the high resolution of the variables available through Modbus communication modules, it can also be used as data source for control actions, such as avoiding feeding energy into the electricity grid in a photovoltaic installation with energy storage.

EM630 B is the perfect solution when Ethernet connection is needed in combination with inverter and energy storage systems or installed in machines and industrial environments to monitor single loads or total consumption.

EM630 W, adding Wi-Fi connectivity, is the right choice in retrofit installations where wired communication is not possible. Specific options, able to combine Wi-Fi and Ethernet with Modbus RTU or M-Bus, permit data retrieving in parallel from different systems at the same time (for instance SCADA and BMS)

Finally, the embedded Webserver makes the configuration of the unit easy and fast, while the datalogger permits precise billing and consumption trend analysis.

### Main functions

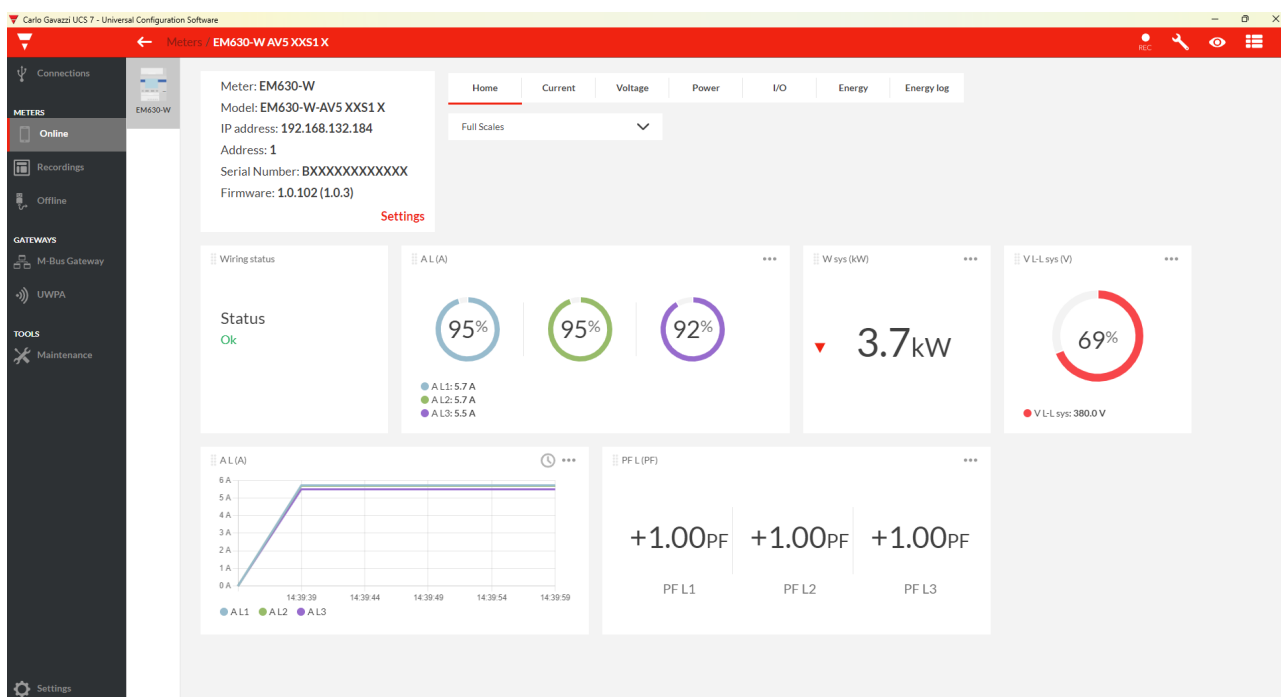
- Active, reactive and apparent energy measurement
- Main electrical variables measurement
- Load run hours and total ON time
- Total harmonic distortion (THD) of current and voltages measurement
- Data transmission to other systems through Modbus TCP/IP and HTTP rest API
- Alarm management for monitoring of up to 4 variables among active/reactive/apparent powers, currents, voltages, frequency and power factor
- Digital output for pulses or alarm transmission management (O1 option, W versions only)
- Measured variables visualisation on the display
- Modbus RTU or M-Bus communication (W versions only)
- Wi-Fi communication, in alternative or in combination with Ethernet (W versions only)

### Main features

- System and phase variables (V L-L, V L-N, A, W/var, VA, PF, Hz)
- Displaying of the active energy with a resolution of 0.001 kWh
- 0.001 Hz frequency resolution
- Average value calculation (dmd) for current and power (kW / kVA)
- Streamlined user interface featuring 3 mechanical buttons
- Modbus TCP/IP (100 ms refresh time) and HTTPS rest API
- Dual Ethernet port (internal switch) for easy daisy chain connection without an external switch (E2 versions)
- Continuous sampling of each voltage and current
- Direct connection to mobile or PC via Wi-Fi 1-to-1 for configuration and diagnostics and LAN connection for fixed installations
- Backlit display
- Bidirectional MID certified versions (W version only)
- MID-certified meter resolution 0.001 kWh
- cULus approved (UL 61010)
- SunSpec compliance
- Operating temperature up to 70 °C / 158 °F temperature
- Operating altitude up to 3000 m / 9842.5 ft
- Real time clock, NTP synchronization (W version only)
- Active energy data logger (current/previous year, current/previous month, current/previous day) (W version only)

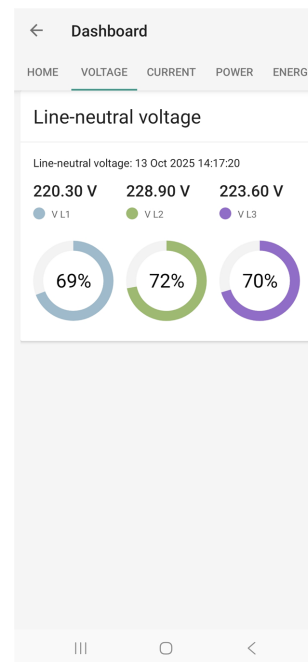
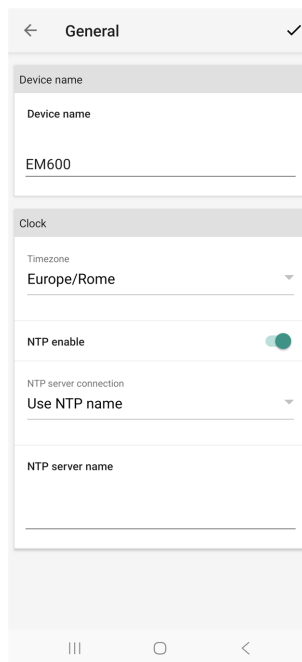
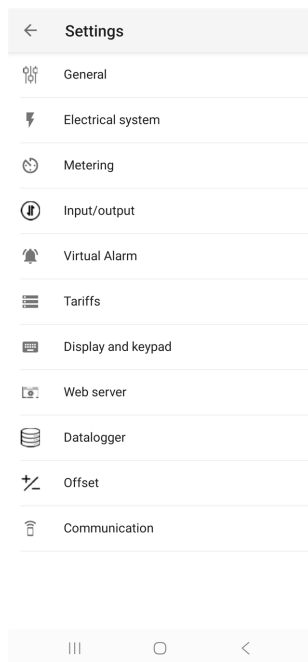
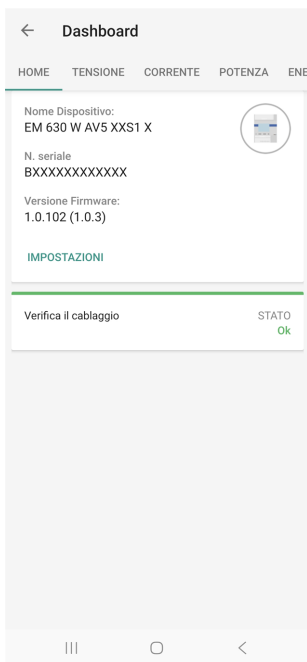
## UCS software

- Free download from Carlo Gavazzi website
- Configuration through RS485 from PC or through UWP3.0 via LAN or the web (UWP Secure Bridge function)
- Setups can be saved offline for serial programming with a single command
- Real time data view for testing and diagnostics
- Notification of possible wiring errors and display of the corrective steps, reassignment of the correct association of the phases or the direction of the currents via software control



## UCS mobile APP

- Free download from Google Play Store
- Configuration through Wi-Fi from Android® mobile phone or tablet
- Setups can be saved offline for recurrent programming with a single command
- Real time data view for testing and diagnostics



## Webserver (W versions only)

It is available on W models, since it requires Wi-Fi to connect. It is accessible from Carlo Gavazzi website and allows:

- Quicksetup and parameter configuration
- Real time data viewing for testing and diagnostics
- Energy logs reading
- Two users: admin user password protected for complete access and configuration, free access user for data visualization

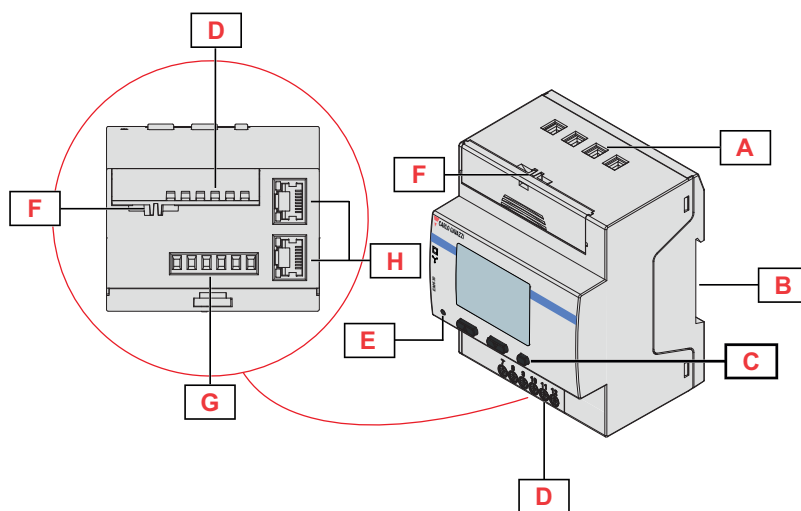
The screenshot shows the EM600 web interface. The top bar is red with the model name 'EM600' and a user icon. A dark sidebar on the left contains navigation options: Dashboard, Energy log, Settings, Quick setup (highlighted), and Info. The main content area is titled 'Quick Setup/General' and features a progress indicator with steps 1, 2, and 3. The configuration fields are as follows:

Section	Field	Value
Device name	Device name	EM600
	Device name	EM600
Clock	Time	Mon Oct 13 17:06:15 2025
	Timezone	Europe/Rome
	Synchronize with this device	SYNC
NTP	NTP enable	ON
	NTP select server connection	Use NTP server name
	NTP server name	

The screenshot shows the General web interface. The top bar is red with the title 'General' and a user icon. A dark sidebar on the left contains navigation options: Dashboard, Energy log, Settings, Quick setup (highlighted), and Info. The main content area is titled 'Quick Setup/General' and features a progress indicator with steps 1, 2, and 3. The configuration fields are as follows:

Section	Field	Value
Device name	Device name	EM600
	Device name	EM600
Clock	Time	Mon Oct 13 17:09:02 2025
	Timezone	Europe/Rome
	Synchronize with this device	SYNC
NTP	NTP enable	ON
	NTP select server connection	Use NTP server name
	NTP server name	

## Structure



**Fig. 1** EM630

Area	Description
A	Voltage inputs
B	DIN rail mounting bracket
C	Browsing and configuration buttons
D	Sliding module (optional digital input and output or RS485 or M-Bus connection)
E	LED
F	Seal housings
G	Current inputs
H	Ethernet RJ45 ports (if present)

## Features

### General

<b>Material</b>	Housing: PBT Transparent cover: polycarbonate
<b>Protection degree*</b>	Front: IP51 Terminals: IP20
<b>Protective class</b>	Class II
<b>Terminals</b>	Voltage inputs: 0.2 to 2.5 mm <sup>2</sup> / 13 to 24 AWG, 0.45 Nm / 3.98 lbin max. Current inputs: 0.2 to 2.5 mm <sup>2</sup> / 13 to 24 AWG, 0.45 Nm / 3.98 lbin max. Inputs, outputs and communication: 0.2 to 1.5 mm <sup>2</sup> / 16 to 24 AWG, 0.4 Nm / 3.54 lbin max.
<b>Overvoltage/Measurement category</b>	Cat. III
<b>Rated impulse voltage</b>	4kV
<b>Pollution degree</b>	2
<b>Mounting</b>	DIN rail
<b>Weight</b>	300 g / 0.66 lb (packaging included)
<b>Dimensions</b>	4 DIN modules

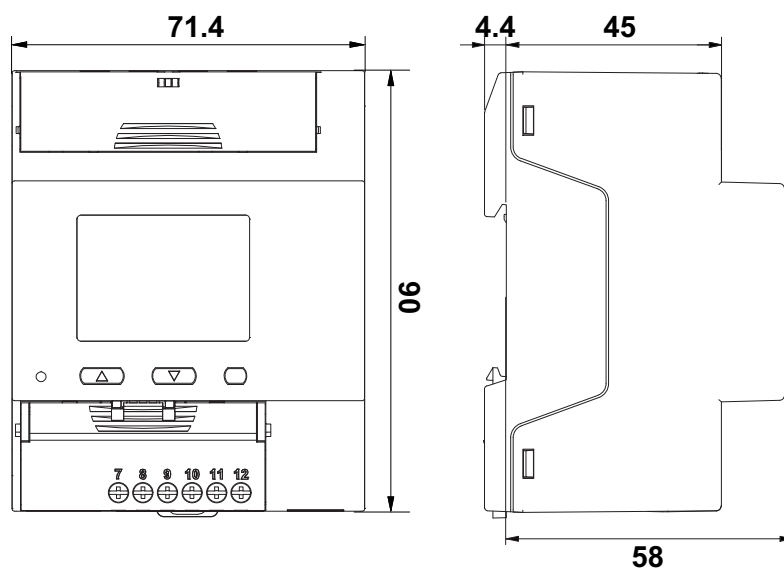


Fig. 2

## Environmental specifications

Operating temperature	From -25 to +70 °C / from -13 to +158 °F
Storage temperature	From -30 to +70 °C / from -22 to 158 °F
Altitude	3000 m / 9842.5 ft

Note: R.H. < 90 % non-condensing @ 40 °C / 104 °F.

## Input and output insulation

Type	CT inputs	Voltage input	Ethernet Modbus TCP	Serial communication	Digital input	Digital output
CT inputs	-	Basic	Double/ Reinforced	Double/ Reinforced	Double/ Reinforced	Double/ Reinforced
Voltage input	Basic	-	Double/ Reinforced	Double/ Reinforced	Double/ Reinforced	Double/ Reinforced
Ethernet	Double/ Reinforced	Double/ Reinforced	-	-		-
Serial communication	Double/ Reinforced	Double/ Reinforced	-	-		-
Digital input	Double/ Reinforced	Double/ Reinforced				
Digital output	Double/ Reinforced	Double/ Reinforced	-	-		-

According to: EN IEC 61010-1, EN IEC 62052-31 (MID). Overvoltage category III. Pollution degree 2.

## Compatibility and conformity

Directives	2014/32/EU (MID) 2014/35/EU (LVT - Low Voltage) 2014/30/EU (EMC - Electro Magnetic Compatibility) 2011/65/EU, 2015/863/EU (Electric-electronic equipment hazardous substances)
Standards	<b>Radio (W versions only):</b> EN 300 328 V2.2.2 <b>Electromagnetic compatibility (EMC) - emissions and immunity:</b> EN 301 489-1 V2.2.3, EN 301 489-17 V3.2.4, EN 62052-11.2021, EN IEC 61000-6-3, EN IEC 61000-6-2 <b>Electrical safety:</b> EN IEC 61010-1, EN IEC 62052-31 <b>Health (W versions only):</b> EN 62311:2020 <b>Metrology:</b> EN IEC 62053-22, EN IEC 62053-23, ANSI C12.1, 50470-3 (MID) <b>FCC (USA) Radio Emission (W versions only):</b> FCC CFR title 47 Part 15C, FCC CFR title 47 Part 2.1091 <b>IC (canadian) radio emission (W versions only):</b> ISED RSS-247 Issue 3; ISED RSS-102 Issue 5

Approvals		 (W versions only)	
-----------	---	--	---

**Note:** the equipment must be installed and operated with minimum distance of 20 cm of the human body.

### Electrical specifications

Electrical system	
Managed electrical system	Single-phase Three single-phase Two-phase (3-wire) Three-phase with neutral (4-wire) Three-phase without neutral (3-wire) Wild leg system (three-phase, four-wire delta)
MID managed electrical system	Three-phase with neutral (4-wire) Three-phase without neutral (3-wire)

Non MID models	
Voltage connection	Direct
Rated voltage L-N ( $U_n$ minimum to $U_n$ maximum)	120 to 277 V
Rated voltage L-L ( $U_n$ minimum to $U_n$ maximum)	208 to 480 V
Voltage tolerance	From 0.8 to 1.15% $U_n$
Overload	Continuous: 1.15 $U_n$ max.
Input impedance	Refer to "Power supply"
Frequency	50/60 Hz

**Note:** EM630 can also be installed in a wild leg system (three phases, four delta wires), where one of the phase-neutral voltages is higher than the other two.

MID models voltage inputs	
Voltage connection	Direct
Rated voltage L-N ( $U_n$ minimum to $U_n$ maximum)	120 to 230 V
Rated voltage L-L ( $U_n$ minimum to $U_n$ maximum)	208 to 400 V
Voltage tolerance	From 0.8 to 1.15% $U_n$
Overload	Continuous: 1.15 $U_n$ max.
Input impedance	Refer to "Power supply"
Frequency	50 Hz

## AV5

Current inputs	CT
Current connection	Via CT
CT transformation ratio	2000 max.
Primary current	10 kA max.
Rated current ( $I_n$ ) input	5 A
Minimum current ( $I_{min}$ )	0.05 A (0.01 $I_n$ )
Maximum current ( $I_{max}$ )	6 A (1.2 $I_n$ )
Start-up current ( $I_{st}$ )	5 mA (0.001 $I_n$ )
Threshold current ( $I_{tr}$ )	0.25 A (0.05 $I_n$ )
Overload	For 500 ms: 120 A (20 $I_{max}$ )
Input impedance	< 0.3 VA
Crest factor	3
Measurement type	with external current transformers

## MV5

Current inputs	MV5
Current connection	Via 333 mV current sensor
CT transformation ratio	-
Primary current	10 kA max.
Rated current ( $I_n$ ) input	333 mV
Minimum current ( $I_{min}$ )	0.03 V (0.01 $I_n$ )
Maximum current ( $I_{max}$ )	0.4 V (1.2 $I_n$ )
Start-up current ( $I_{st}$ )	0.003 V (0.001 $I_n$ )
Threshold current ( $I_{tr}$ )	0.017 V (0.05 $I_n$ )
Overload	For 500 ms: 8 V
Input impedance	100 k $\Omega$
Crest factor	1.414 @ $I_{max}$
Measurement type	with external current sensors

### Power supply

Type	Self power supply
Consumption	3 W / 5.5 VA
Frequency	50/60 Hz

## Measurements

Method	TRMS measurements of distorted waveforms
--------	--

## Energy metering

Energy metering depends on the measurement type you chose.

### A measurement (Easy connection)

Models: MID PFA or non-MID with selection A

Irrespective of the current direction, the power always has a plus sign and contributes to increase the positive energy meter. The negative energy meter is not available.

### B measurement (Bidirectional)

Models: PFB or non-MID with selection B

For each measuring time interval, the individual phase energies with a plus sign are summed to increase the positive energy meter (kWh+), while the others increase the negative one (kWh-).

Example:

$P L1 = +2 \text{ kW}$ ,  $P L2 = +2 \text{ kW}$ ,  $P L3 = -3 \text{ kW}$

Integration time = 1 hour

$\text{kWh}+ = (2+2) \times 1\text{h} = 4 \text{ kWh}$

$\text{kWh}- = 3 \times 1\text{h} = 3\text{kWh}$

### C measurement (Net Bidirectional)

Models: PFC or non-MID with selection C

For every measuring interval time, the energies of the single phases are summed; according to the sign of the result, the positive (kWh+) or negative totalizer (kWh-) is increased.

Example:

$P L1 = +2 \text{ kW}$ ,  $P L2 = +2 \text{ kW}$ ,  $P L3 = -3 \text{ kW}$

Integration time = 1 hour

$\text{kWh}+ = (+2+2-3) \times 1\text{h} = (+1) \times 1\text{h} = 1 \text{ kWh}$

$\text{kWh}- = 0 \text{ kWh}$

### Available measurements

Active energy	Unit	System	Phase
Imported (+) Total	kWh+	•	•
Imported (+) partial	kWh+	•	-
Exported (-) Total	kWh-	•	•
Exported (-) partial	kWh-	•	-
Imported (+) Total by tariff (t1, t2)	kWh+	•	-
Quadrant I, II, III, iV	kW	•	-

Reactive energy	Unit	System	Phase
Imported (+) Total	kvarh+	•	•
Imported (+) partial	kvarh+	•	-
Exported (-) Total	kvarh-	•	•
Exported (-) partial	kvarh-	•	-
Quadrant I, II, III, iV	kvarh	•	-

Apparent energy	Unit	System	Phase
Total	kVAh	•	-
Partial	kVAh	•	-
Quadrant I, II, III, iV	kVAh	•	-

Run hour meter	Unit	System	Phase
Total (kWh+)	hh:mm	•	-
Partial (kWh+)	hh:mm	•	-
Total (kWh-)	hh:mm -	•	-
Partial (kWh-)	hh:mm -	•	-
Total ON time	hh:mm	•	-

Electrical variable	Unit	System	Phase
Voltage L-N	V	•	•
Voltage L-L	V	•	•
Current	A	•	•
DMD	A	-	•
DMD MAX	A	-	•
Neutral current	A	•	-
Active power	W	•	•
DMD	W	•	-
DMD MAX	W	•	-

Electrical variable	Unit	System	Phase
Apparent power	VA	•	•
DMD	VA	•	-
DMD MAX	VA	•	-
Reactive power	Var	•	•
Power factor	PF	•	•
Frequency	Hz	•	-
THD Current*	THD A %	-	•
THD Voltage L-N*	THD L-N %	-	•
THD Voltage L-L*	THD L-L %	-	•

\* Up to 31<sup>st</sup> harmonic

**Note:** the available variables depend on the type of system set.

*PFA models: total imported active energy (kWh TOT) is the only MID certified meter. Apparent energy, reactive energy and exported active energy are not MID certified. Partial meters are not MID certified.*

*PFB and PFC models: total imported active energy (kWh+ TOT) and total exported active energy (kWh- TOT) are the only MID certified meters. Apparent energy, reactive energy are not MID certified. Partial meters are not MID certified.*

## Measurement accuracy

Phase-phase voltage	
From $U_n$ minimum -20% to $U_n$ maximum +15%	+/- 0.2% rdg
Phase-neutral voltage	
From $U_n$ minimum -20% to $U_n$ maximum +15%	+/- 0.2% rdg
Frequency	
From 45 to 65 Hz	+/- 0.1% rdg

## AV5

Current	
From $0.05 I_n$ to $I_{max}$	+/- 0.3% rdg
From $0.01 I_n$ to $0.05 I_n$	+/- 0.6% rdg

Active and apparent power	
From 0.05 $I_n$ to $I_{max}$ (PF=1)	+/- 0.5% rdg
From 0.01 $I_n$ to 0.05 $I_n$ (PF=1)	+/- 1% rdg
From 0.1 $I_n$ to $I_{max}$ (PF=0.5 L - 0.8 C)	+/- 0.6% rdg
From 0.02 $I_n$ to 0.1 $I_n$ (PF=0.5 L - 0.8 C)	+/- 1% rdg
Active energy	Class 0.5 S (EN IEC 62053-22) Class B (EN 50470-3 (MID))

Reactive power	
From 0.1 $I_n$ to $I_{max}$ ( $\sin\phi=0.5$ L - 0.5 C) From 0.05 $I_n$ to $I_{max}$ ( $\sin\phi=1$ )	+/- 2% rdg
From 0.05 $I_n$ to 0.1 $I_n$ ( $\sin\phi=0.5$ L - 0.5 C) From 0.02 $I_n$ to 0.05 $I_n$ (PF=1)	+/- 2.5% rdg
Reactive energy	Class 2 (EN IEC 62053-23)

## MV5

Current	
From $I_{min}$ to 0.05 $I_n$ (PF=1)	+/- 1% rdg
From 0.05 $I_n$ to $I_{max}$ (PF=1)	+/- 0.5% rdg
From 0.05 $I_n$ to 0.1 $I_n$ (PF=0.5 L - 0.8 C)	+/- 1% rdg
From 0.1 $I_n$ to $I_{max}$ (PF=0.5 L - 0.8 C)	+/- 0.6% rdg

Active and apparent power	
From 0.05 $I_n$ to $I_{max}$ (PF=1)	+/- 0.5% rdg
From 0.01 $I_n$ to 0.05 $I_n$ (PF=1)	+/- 1% rdg
From 0.1 $I_n$ to $I_{max}$ (PF=0.5 L - 0.8 C)	+/- 0.6% rdg
From 0.02 $I_n$ to 0.1 $I_n$ (PF=0.5 L - 0.8 C)	+/- 1% rdg
Active energy	Equivalent to Class 0.5 (EN IEC 62053-21)

Reactive power	
From 0.1 I <sub>n</sub> to I <sub>max</sub> (sinφ=0.5 L - 0.5 C) From 0.05 I <sub>n</sub> to I <sub>max</sub> (sinφ=1)	+/- 2% rdg
From 0.05 I <sub>n</sub> to 0.1 I <sub>n</sub> (sinφ=0.5 L - 0.5 C) From 0.02 I <sub>n</sub> to 0.05 I <sub>n</sub> (PF=1)	+/- 2.5% rdg
Reactive energy	Equivalent to Class 2 (EN IEC 62053-23)

Measurement accuracy according to EN IEC 61557-12 (MID models)	
Active power	Performance class 1
Active energy	Performance class 2

### Measurement resolution

Variable	Display resolution	Resolution by serial communication
Energy	0.001 kWh/kvarh/kVAh	0.0001 kWh/kvarh/kVAh
Single phase energy	0.001 kWh	0.001 kWh
Power	0.001 kW/kvar/VA	0.1 W/var/VA
Current	0.001 A	
Voltage	0.1 V	
Frequency	0.001 Hz	
THD	0.01 %	
Power factor	0.01	0.001

\*Note: value referred to CT ratio =1.

## Display

Type	Matrix LCD 128 x 96 pixels
Refresh time	500 ms
Description	Backlit LCD
Variable readout	Instantaneous: 5+1 dgt or 5+3 dgt Power factor: 1+2 dgt Energy: 8+3 dgt



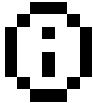





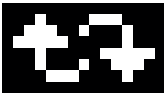

## Clock (W version only)

Type	RTC
Accuracy	25 ppm
Synchronization	NTP (recommended) Modbus Webserver
Backup	lithium battery

**Note:** It is highly recommended to synchronize the clock using NTP server.

## Display icons description

The table reports the icons that can appear on the display.

Icon	Description
	Off: Ethernet link inactive (cable disconnected or no link) ON: Ethernet link active (cable connected and link detected) Note: The icon shows only the physical link status. Correct network settings required for communication.
	Off: Wi-Fi LAN disabled Blinking: Wi-Fi LAN active but not connected Fixed: Wi-Fi LAN connected
	Wiring information: virtual correction via UCS
	Current range exceeded: the measured value is still displayed
	Voltage range exceeded: the measured value is still displayed
	Undervoltage: the measured value is displayed anyway
	Frequency in an out-of-range condition
	Fixed: internal failure Blinking: alarm signal
	Wiring error
	Reading or writing command is addressed to EM630

 LED
**AV5**

The LED is Red coloured. Pulse weight: proportional to positive energy (display page 1) or negative energy (display page 2) and depending on the CT ratio, 16 Hz maximum frequency.

Weight (kWh per pulse)	CT ratio
0.001	$CT \leq 7$
0.01	$7 < CT \leq 70$
0.1	$70 < CT \leq 700$
1	$700 < CT \leq 2000$












**MV5**

The LED is Red coloured. Pulse weight: proportional to positive energy (display page 1) or negative energy (display page 2) and depending on Primary current ( $I_n$ ), 16Hz maximum frequency.

Weight (kWh per pulse)	Primary current ( $I_n$ )
0.001	$I_n \leq 35$
0.01	$35 < I_n \leq 350$
0.1	$350 < I_n \leq 3500$
1	$I_n > 3500$

## Symbols

The table describes all the symbols that you can find in the documents and on the product.

Symbol	Description
	Dangerous voltage
	Danger, live parts
	Caution
	Provides essential information on completing the task that should not be neglected
	Manual symbol
	Safety sign notice
	The product is not to be discarded with normal household waste
	Double insulation
	Single phase
	Three phase (four-wire)
	Three phase (three-wire)

## Communication ports

### Ethernet port (E2 versions)

<b>Protocol</b>	Modbus TCP/IP HTTPS REST API DHCP mDNS
<b>Devices on the same bus</b>	Maximum 5 connections simultaneously
<b>Connection type</b>	RJ45 connector (10 Base-T, 100 Base-TX), maximum distance 100 m, Integrated switch function to connect another Ethernet device
<b>Configuration parameters</b>	DHCP client mDNS Modbus TCP enabling HTTPS REST API
<b>Cable type</b>	Minimum Cat 5, Standard EIA/TIA T568B Ethernet Patch Cable or Ethernet Crossover Cable (autodetection)
<b>Refresh time</b>	Modbus TCP/IP: $\leq 100$ ms HTTPS Rest API: $\leq 200$ ms HTTPS Webserver: $\leq 3$ s
<b>Configuration mode</b>	Via keypad, UCS software/APP or Webserver

### Modbus RTU (S1 versions)

<b>Protocol</b>	Modbus RTU
<b>Devices on the same bus</b>	Max 247 (1/8 unit load)
<b>Communication type</b>	Multidrop, bidirectional
<b>Connection type</b>	2 wires
<b>Configuration parameters</b>	Modbus address (from 1 to 247) Baud rate (9.6/19.2/38.4/57.6/115.2 kbps) Parity (None/Even) Stop bit (1 or 2)
<b>Refresh time</b>	$\leq 100$ ms
<b>Configuration mode</b>	Via keypad or UCS software/APP or Webserver

### M-Bus (M1 versions)

<b>Protocol</b>	M-Bus according to EN IEC 13757-3:2013
<b>Devices on the same bus</b>	Max 250 (1 unit load)
<b>Connection type</b>	2 wires
<b>Configuration parameters</b>	Primary address (1 to 250) Baudrate (0.3/2.4/9.6 kbps)
<b>Refresh time</b>	≤ 100 ms
<b>Configuration mode</b>	Via keypad

### Wi-Fi

General	
<b>Technology</b>	Wi-Fi IEEE 802.11 b/g/n 20/40 MHz
<b>Centre frequency range of operating channel</b>	2412 – 2472 MHz
<b>Maximum EIRP output power</b>	18.34 dBm
<b>Number of channels</b>	13
<b>Channel bandwidth</b>	20 MHz, 40 MHz
<b>Modulations</b>	DSSS, OFDM
<b>Number of Tx Antennas</b>	1
<b>Type of antenna</b>	PCB antenna
<b>Antenna gain</b>	2.87 dBi
<b>Installation category</b>	Mobile
<b>Connectivity</b>	2.4 GHz Spectrum Capabilities
<b>Modes</b>	SoftAP (Wi-Fi 1-to-1) Station (Wi-Fi LAN)

Wi-Fi 1-to-1	
<b>Protocol</b>	HTTPS (webserver)
<b>Mode</b>	SoftAP
<b>Bit rate</b>	Up to 150 Mbps
<b>Configuration parameters</b>	Enable SSID Password
<b>Refresh time</b>	≤ 3 s
<b>Configuration mode</b>	UCS software/APP and Webserver

Wi-Fi LAN	
<b>Protocol</b>	Modbus TCP/IP, HTTPS REST API, HTTPS (webserver)
<b>Mode</b>	Station
<b>Bit rate</b>	Up to 150 Mbps
<b>Configuration parameters</b>	Enable SSID Password DHCP IP address Netmask Gateway
<b>Refresh time</b>	Modbus TCP/IP: $\leq 100$ ms REST API: $\leq 200$ ms HTTPS Webserver: $\leq 3$ s
<b>Configuration mode</b>	UCS software/APP and Webserver

## Digital inputs/outputs

### Digital inputs (S1, M1 or O1 versions)

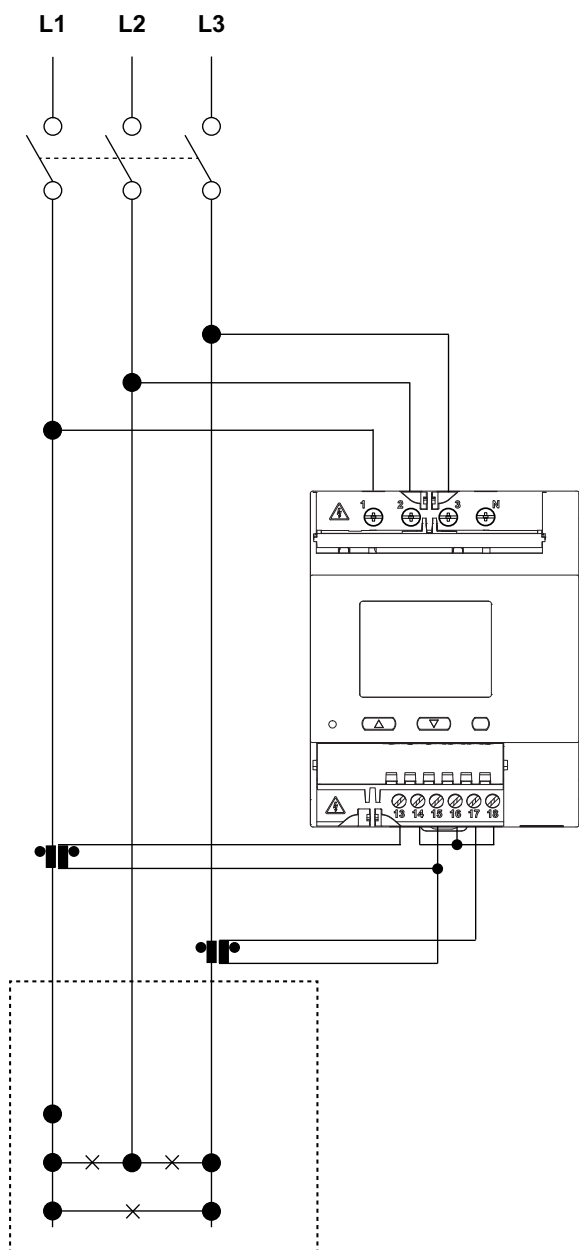
Connection type	Screw terminals
Number of inputs	1
Type	Free contact
Function	Remote status Tariff management Partial meter start/pause Partial meter reset
Features	Open contact voltage: 5 Vdc +/- 5% Closed contact voltage: 5 mA max Input impedance: 11.6 k $\Omega$ Open contact resistance: $\geq$ 25 k $\Omega$ Closed contact resistance: $\leq$ 840 $\Omega$ Maximum voltage applicable with no damages: 30 V ac
Configuration parameters	Input function
Configuration mode	Via keypad or software/app and Webserver

### Digital output (O1 versions)

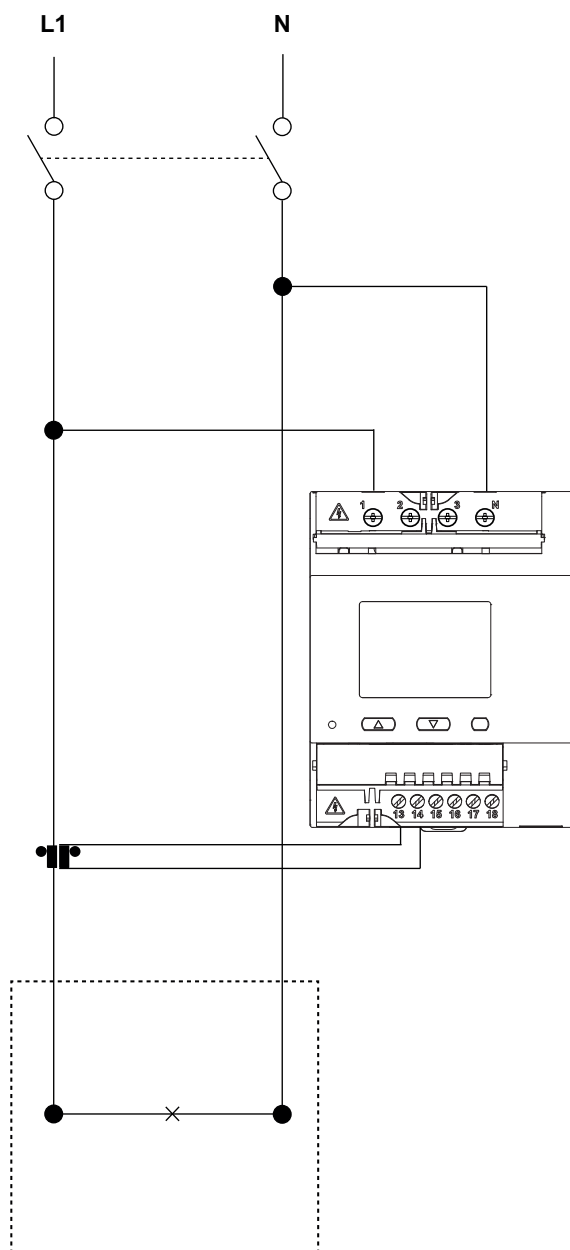
Connection type	Screw terminals
Maximum number of outputs	1
Type	Opto-mosfet
Function	Pulse output or alarm output
Features	$V_{ON}$ 2.5 V ac/dc, max 100 mA $V_{OFF}$ 42 V ac/dc
Configuration parameters	Output function (pulse/alarm) Pulse weight (from 0.001 to 10 kWh per pulse) Pulse duration (30 or 100 ms) Output normal status (NO or NC)
Configuration mode	Via keypad, UCS software/APP and Webserver

**Note:** type S0, class B in accordance with EN IEC 62053-31

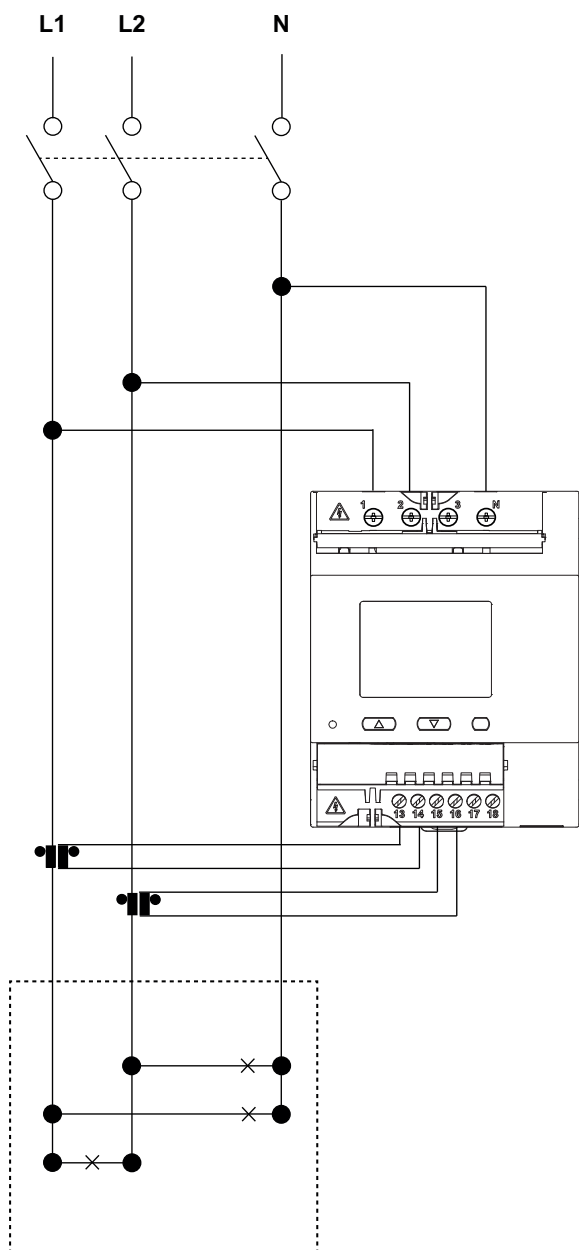




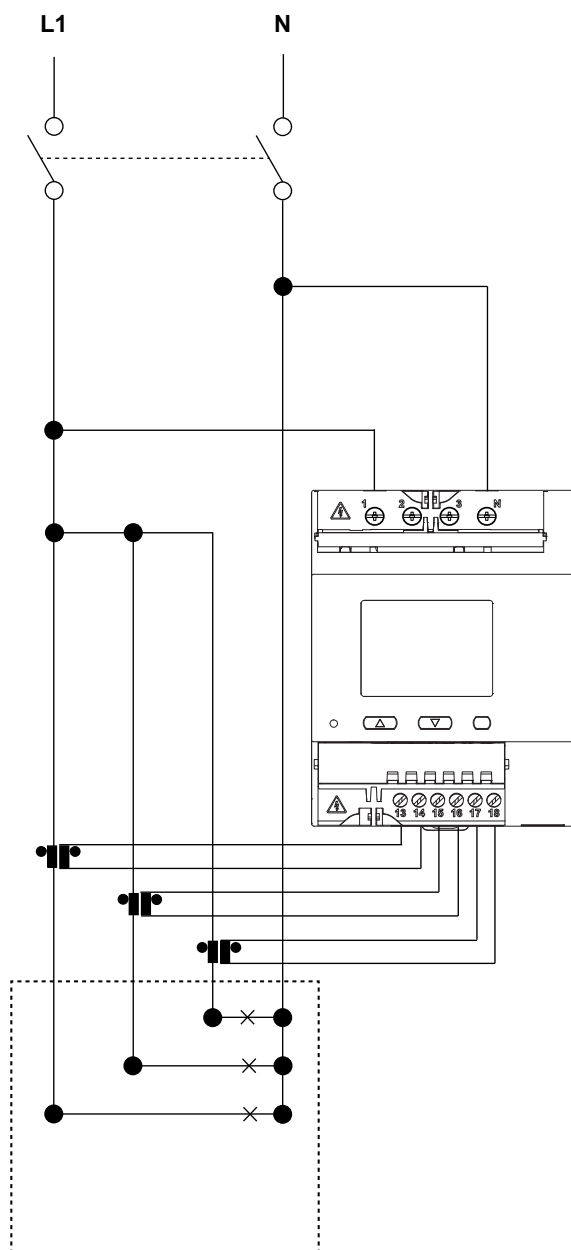
**Fig. 5** Three-phase without neutral (3-wire).



**Fig. 6** Single-phase system.



**Fig. 7** Two-phase system with neutral (3-wire).



**Fig. 8** Single-phase system, 3 loads

## Digital input/output

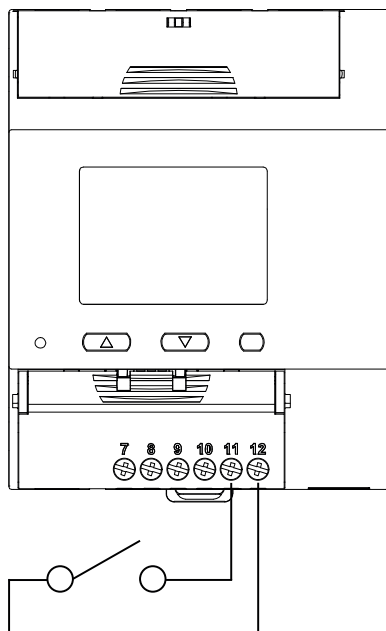


Fig. 9 Input (S1, O1 or M1)

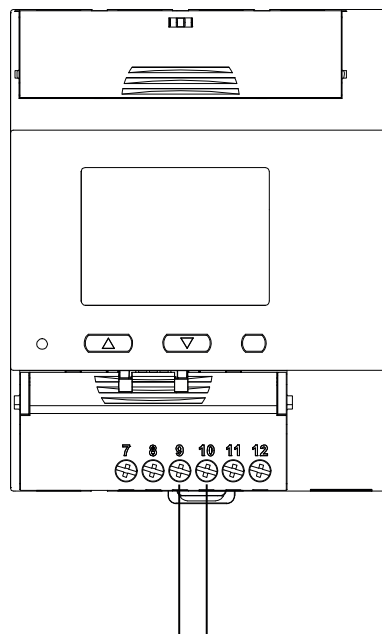


Fig. 10 Output (option O1)

## Communication

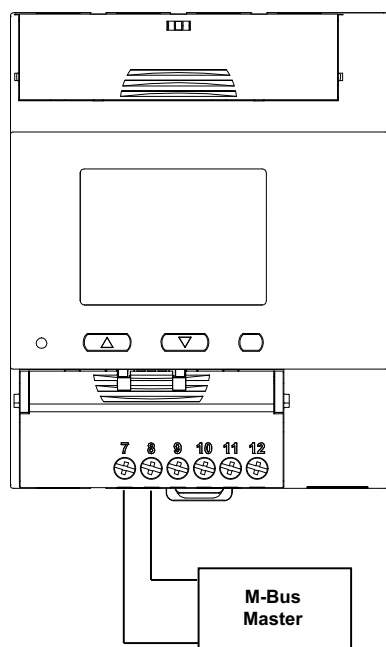


Fig. 11 M-Bus (option M1)

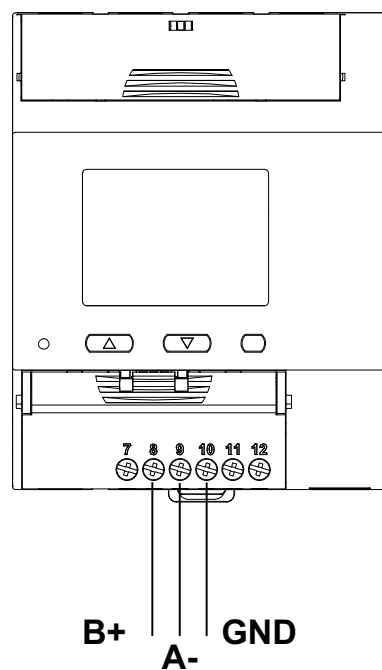
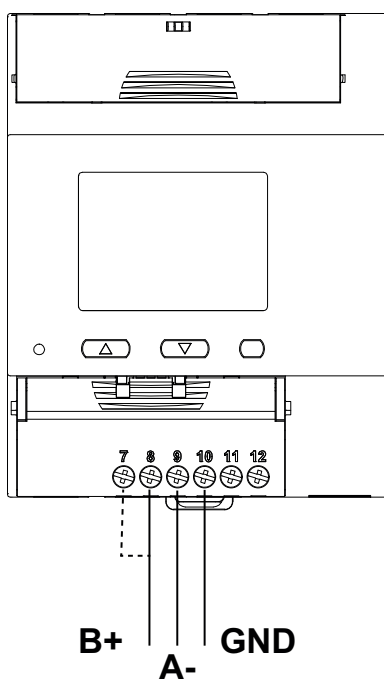


Fig. 12 RS485 port (option S1)



*Fig. 13 Last device on RS485 port (option S1)*

## References

Order code

 **EM630 B**  **3X E2 XX X**

Enter the code option instead of

Code	Options	Description
EM630 B	-	-
<input type="checkbox"/>	AV5	5 A current transformer
	MV5	333 mV current sensor
3X	-	Three phase, self power supply
E2	-	Two Ethernet Modbus TCP ports
XX	-	-
X	-	CE, cULus


**EM630 W**  **3X**   

Enter the code option instead of


Code	Options	Description
<b>EM630 W</b>	-	Wi-Fi and RTC
<input type="checkbox"/>	<b>AV5</b>	5 A current transformer
	<b>MV5</b>	333 mV current sensor
<b>3X</b>	-	Three phase, self power supply
<input type="checkbox"/>	<b>XX</b>	Wi-Fi LAN and Wi-Fi 1-to-1
	<b>E2</b>	Wi-Fi LAN and Wi-Fi 1-to-1 and two Ethernet ports
<input type="checkbox"/>	<b>S1</b>	RS485 Modbus RTU and digital input
	<b>O1</b>	M-Bus and Digital input
	<b>M1</b>	Digital output and digital input
<input type="checkbox"/>	<b>X</b>	CE, cULus
	<b>PFA</b>	CE, MID easy connection (AV5 option only)
	<b>PFB</b>	CE, MID Bidirectional (AV5 option only)
	<b>PFC</b>	CE, MID Net Bidirectional (AV5 option only)

- PFA: Easy connection, the total energy totalizer (kWh+) is certified according to MID.
- PFB: Bidirectional, total imported active energy (kWh+ TOT) and Total exported active energy (kWh- TOT) are MID certified meters; manufactured in Italy.

*Note: for each measuring time interval, the individual phase energies with a plus sign are summed up to increase the positive energy meter (kWh+), while the others increase the negative one (kWh-).*

- PFC: Bidirectional, total imported active energy (kWh+ TOT) and Total exported active energy (kWh- TOT) are MID certified meters; manufactured in Italy.

*Note: for each measuring time interval, the energies of the individual phases are summed up; according to the sign of the result, the system increases the positive totalizer (kWh+) or the negative one (kWh-).*


**CARLO GAVAZZI compatible components**

Purpose	Component name/code key	Notes
Configure analyzer via desktop application	UCS software	Available for free download at <a href="http://www.gavazziautomation.com">www.gavazziautomation.com</a>
Aggregate, store and transmit data to other systems	UWP	For further information please refer to <a href="http://www.gavazziautomation.com">www.gavazziautomation.com</a>
CT series	CTA, CTD, CTV	For further information please refer to <a href="http://www.gavazziautomation.com">www.gavazziautomation.com</a>



COPYRIGHT ©2026

Content subject to change. Download the PDF: [www.gavazziautomation.com](http://www.gavazziautomation.com)