



LOW NOISE, WIDEBAND, HIGH IP3

# Monolithic Amplifier

## CMA-83LN+

50Ω 0.5 to 8 GHz

### THE BIG DEAL

- Ceramic, Hermetic, Nitrogen Filled
- Low Profile Case, 0.045" High
- Low Noise Figure, 1.3 dB at 2 GHz
- High IP3, +30 dBm Typ. at 2 GHz
- High P1dB, +20.3 dBm Typ. at 2 GHz and +6 V
- Excellent Gain Flatness, ±1.2 dB Over 0.5 to 7 GHz and +6 V
- Small Size, 3x3x1.14 mm



Generic photo used for illustration purposes only

CASE STYLE: DL1721

### APPLICATIONS

- High Rel Systems
- Defense and Aerospace
- WiFi
- WLAN
- UMTS
- LTE
- WiMAX
- S-Band Radar
- C-Band Satcom

#### +RoHS Compliant

The +Suffix identifies RoHS Compliance. See our website for methodologies and qualifications

MIL SCREENING AVAILABLE  
PLEASE CONSULT APPLICATIONS DEPT.

### PRODUCT OVERVIEW

The CMA-83LN+ is a pHEMT based wideband, low noise MMIC amplifier with a unique combination of low noise, high IP3, and flat gain over wideband making it ideal for sensitive, high-dynamic-range receiver applications. This design operates on a single +5 V or +6 V supply, is well matched for 50Ω and comes in a tiny, low profile package (3x3x1.14 mm), accommodating dense circuit board layouts. The amplifier is bonded to a multilayer integrated LTCC substrate, then hermetically sealed under a controlled Nitrogen atmosphere with gold-plated cover, eutectic Au-Sn solder, and Ni-Pd-Au termination finish. CMA-series amplifiers are capable of meeting MIL requirements for gross leak, fine leak, thermal shock, vibration, acceleration, mechanical shock, and HTOL. The testing can be done if requested.

### KEY FEATURES

Feature	Advantages
Hermetically Sealed	Ideal for use anywhere long-term reliability adds bottom-line value: high moisture areas, busy production lines, high-speed distribution centers, heavy industry, outdoor settings, and unmanned facilities, as well as military applications.
Low Noise, 1.3 dB at 2 GHz	Enables lower system noise figure performance.
High IP3 +30 dBm at 2 GHz +26.7 dBm at 8 GHz	Combination of low noise and high IP3 makes this MMIC amplifier ideal for use in low noise receiver front end (RFE) as it gives the user advantages of sensitivity and two-tone IM performance at both ends of the dynamic range.
Low Operating Voltage, +5 V/+6 V	Achieves high IP3 using low voltage.
Wide Bandwidth with Flat Gain • ±1.2 dB over 0.5 to 7 GHz • ±1.5 dB over 0.5 to 8 GHz	Enables a single amplifier to be used in many wideband applications including defense, instrumentation and more.
Ceramic Hermetic Package	Low inductance, repeatable performance, outstanding reliability in tough operating conditions, and small size (3x3x1.14 mm).

REV. D  
ECO-025417  
CMA-83LN+  
MCL NY  
250502





LOW NOISE, WIDEBAND, HIGH IP3

# Monolithic Amplifier

**CMA-83LN+**

50Ω 0.5 to 8 GHz

**ELECTRICAL SPECIFICATIONS<sup>1</sup> AT +25°C AND +5 V/+6 V, UNLESS NOTED OTHERWISE**

Parameter	Condition (GHz)	V <sub>dd</sub> = +6.0 V			V <sub>dd</sub> = +5.0 V			Units
		Min.	Typ.	Max.	Min.	Typ.	Max.	
Frequency Range		0.5		8.0	0.5		8.0	GHz
Noise Figure	0.5		1.6			1.6		dB
	2.0		1.3	1.8		1.3		
	4.0		1.5			1.5		
	5.0		1.6			1.6	2.2	
	8.0		1.8			1.8		
Gain	0.5		21.2			20.2		dB
	2.0	18.5	21.5	24.4		20.8		
	4.0		20.6			19.7		
	5.0		20.1		14.9	19.3		
	8.0		19.2			18.7		
Input Return Loss	0.5		12.3			11.2		dB
	2.0		17.2			16.3		
	4.0		10.0			9.2		
	5.0		8.3			7.7		
	8.0		6.5			6.0		
Output Return Loss	0.5		14.4			15.0		dB
	2.0		17.5			21.4		
	4.0		20.1			17.4		
	5.0		13.6			12.4		
	8.0		6.4			6.3		
Output Power @ 1 dB Compression	0.5		+17.6			+16.0		dBm
	2.0		+20.3			+19.5		
	4.0		+18.0			+16.0		
	5.0		+18.8		+13.0	+16.6		
	8.0		+16.9			+16.4		
Output IP3	0.5		+29.4			+26.1		dBm
	2.0		+30.1			+26.6		
	4.0		+28.1			+24.8		
	5.0		+27.2		+12.3	+24.0		
	8.0		+26.7			+24.5		
Device Operating Voltage			+6.0			+5.0		V
Device Operating Current			62	94		50		mA
DC Current Variation vs. Temperature <sup>2</sup>			-157			-109		μA/°C
DC Current Variation vs. Voltage at 25°C			0.016			0.016		mA/mV
Thermal Resistance			70			70		°C/W

1. Measured on Mini-Circuits Characterization test board TB-994+. See Characterization Test Circuit (Fig. 1).  
 2. (Current at +125°C - Current at -45°C)/170

**ABSOLUTE MAXIMUM RATINGS<sup>3</sup>**

Parameter	Ratings
Operating Temperature (Ground Lead)	-40°C to +125°C
Storage Temperature	-65°C to +150°C
Junction Temperature	150 mA
Total Power Dissipation	0.95 W
Input Power (CW), V <sub>d</sub> = +5 V,+6 V <sup>4</sup>	+19 dBm (5 minutes max.) +16 dBm (continuous)
DC Voltage	+7 V

3. Permanent damage may occur if any of these limits are exceeded. These ratings are not intended for continuous normal operation.  
 4. Measured on Mini-Circuits test board, TB-994+.





LOW NOISE, WIDEBAND, HIGH IP3

# Monolithic Amplifier

**CMA-83LN+**

50Ω 0.5 to 8 GHz

## SIMPLIFIED SCHEMATIC AND PAD DESCRIPTION

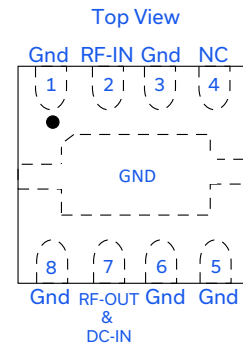
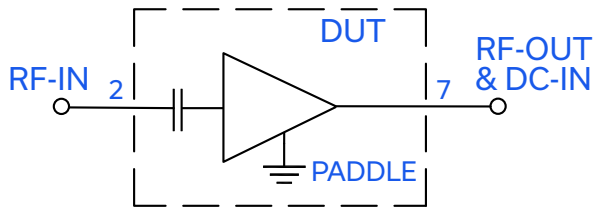

Function	Pin Number	Description
RF-IN	2	Connects to RF input and to ground via L1 (optional blocking capacitor of 100pF may be used)
RF-OUT and DC-IN	7	Connects to RF out via C3 and $V_{dd}$ via L2
GND	1,3,5,6,8, Paddle	Connects to ground
NC	4	Not used internally. Connected to ground on test board.

## RECOMMENDED APPLICATION AND CHARACTERIZATION TEST CIRCUIT

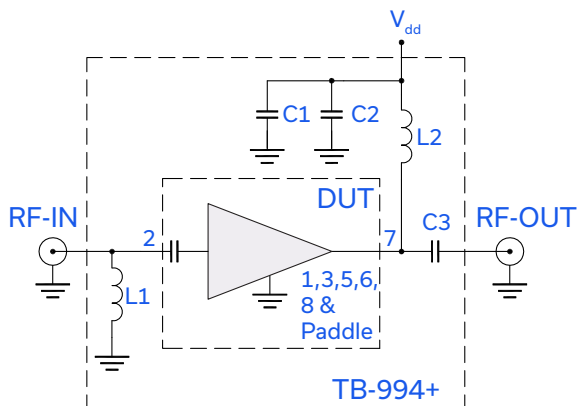

Component	Vendor	Vendor P/N	Value	Size
C1	Murata	GRM155R71E103KA01D	0.01 $\mu$ F	0402
C2	Murata	GJM1555C1H100JB01D	10 pF	0402
C3	Murata	GRM1555C1H101JA01D	100 pF	0402
L1	Murata	LQG15HS18NJ02D	18 nH	0402
L2	Coilcraft	0402CS-39NXGLW	39 nH	0402

Fig 1. Application and Characterization Circuit

Note: This block diagram is used for characterization. (DUT soldered on Mini-Circuits Characterization test board TB-994+) Gain, Return Loss, Output Power at 1 dB Compression (P1dB), Output IP3 (OIP3) and Noise Figure measured using Agilent's N5242A PNA-X microwave network analyzer.

Conditions:

1. Gain and Return Loss:  $P_{IN} = -25$  dBm
2. Output IP3 (OIP3): Two tones, spaced 1 MHz apart, 0 dBm/tone at output.



LOW NOISE, WIDEBAND, HIGH IP3

# Monolithic Amplifier

## CMA-83LN+

50Ω 0.5 to 8 GHz

### SUGGESTED PCB LAYOUT (PL-606)

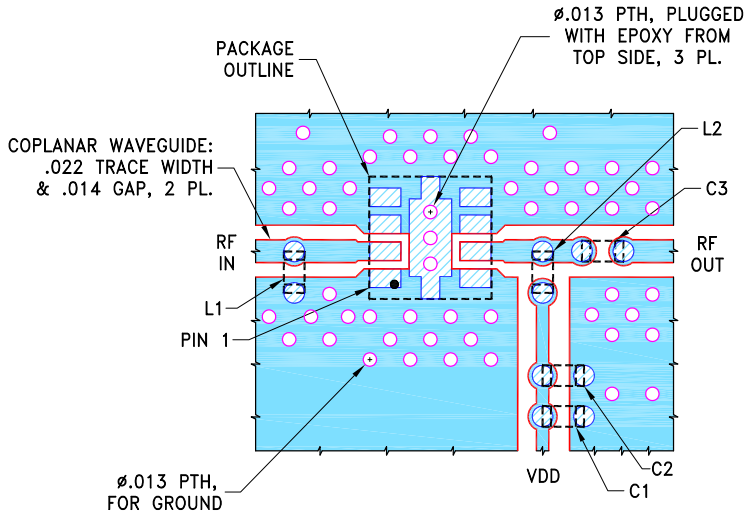

COMPONENT	SIZE
C1-C3, L1-L2	0402

#### NOTES:

1. TRACE WIDTH & GAP PARAMETERS ARE SHOWN FOR ROGERS R04350B WITH DIELECTRIC THICKNESS  $.010 \pm .001$ ". COPPER: 1/2 OZ. EACH SIDE. FOR OTHER MATERIALS TRACE WIDTH & GAP MAY NEED TO BE MODIFIED.
2. CHIP COMPONENT FOOT PRINTS SHOWN FOR REFERENCE. FOR COMPONENT VALUES REFER TO TB-994+.
3. BOTTOM SIDE OF THE PCB IS CONTINUOUS GROUND PLANE.

- DENOTES PCB COPPER LAYOUT WITH SMOBC (SOLDER MASK OVER BARE COPPER).
- DENOTES COPPER LAND PATTERN FREE OF SOLDER MASK.

### PRODUCT MARKING

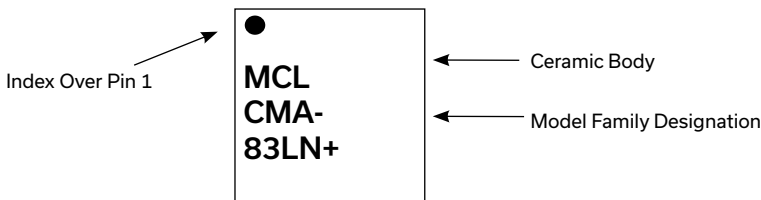

Markings in addition to model number designation may appear for internal quality control purposes.



LOW NOISE, WIDEBAND, HIGH IP3

# Monolithic Amplifier

## CMA-83LN+

50Ω 0.5 to 8 GHz

ADDITIONAL DETAILED TECHNICAL INFORMATION IS AVAILABLE ON OUR DASHBOARD. [CLICK HERE](#)

Performance Data & Graphs	Table Graphs S-Parameter (S2P Files) Data Set (.zip file)
Case Style	DL1721 Ceramic package, exposed paddle, Terminal Finish: Ni,Pd,Au
Tape & Reel Standard Quantities Available on Reel	F66-1 7" Reels with 20, 50, 100, 200, 500, 1000 & 2000 devices
Suggested Layout for PCB Design	PL-606
Evaluation Board	TB-994+
Environmental Ratings	ENV68

### ESD RATING

Human Body Model (HBM): Class 1A (250 V to < 500 V) in accordance with ANSI/ESD STM 5.1 - 2001  
Machine Model (MM): Class M1 (pass 50 V) in accordance with ANSI/ESD STM5.2-1999

### MSL RATING

Moisture Sensitivity: MSL1 (these parts are hermetic, air cavity and therefore, MSL ratings do not strictly apply. For handling purpose, use MSL1)

### QUALIFICATION TESTING

The table below shows the initial qualification testing performed. If required, parts can be subjected to 100% screening and qualifications testing per MIL standard requirement.

	Test Description	Test Method/Process	Results
1	Hermeticity (fine and gross leak)	MIL-STD-202 Method 112, Cond. C & D	Pass
2	Acceleration, 30Kg, Y1 Direction	MIL-STD-883 Method 2001 Cond. E	Pass
3	Vibration , 10-2000Hz sine, 20g, 3 axis	MIL-STD-202 Method 204, Cond. D	Pass
4	Mechanical shock	MIL-STD-202 Method 213, Cond . A	Pass
5	PIND 20G's @130 Hz	MIL-STD-750 Method 2052.2	Pass
6	Temp Cycle -55C/+125C, 1000 Cycles	MIL-STD-202 Method 107	Pass
7	Autoclave, 121C, RH 100%, 15 Psig, 96 hrs	JESD22-A102C	Pass
8	HTOL, 1000hrs, 105C at rated Voltage condition	MIL-STD-202 Method 108, Cond . D	Pass
9	Bend Test	JESD22-B113	Pass
10	Resistance to soldering heat, 3x reflow, 260C peak	JESD22-B102	Pass
11	Drop Test	JESD22-B111	Pass
12	Adhesion Strength	Push Test>10 lb	Pass

#### NOTES

- A. Performance and quality attributes and conditions not expressly stated in this specification document are intended to be excluded and do not form a part of this specification document.
- B. Electrical specifications and performance data contained in this specification document are based on Mini-Circuits' applicable established test performance criteria and measurement instructions.
- C. The parts covered by this specification document are subject to Mini-Circuits' standard limited warranty and terms and conditions (collectively, "Standard Terms"); Purchasers of this part are entitled to the rights and benefits contained therein. For a full statement of the standard terms and the exclusive rights and remedies thereunder, please visit Mini-Circuits' website at [www.minicircuits.com/terms/viewterm.html](http://www.minicircuits.com/terms/viewterm.html)

