



### THE BIG DEAL

- DC to 18 GHz
- High Power Handling, 50 W
- Excellent VSWR, 1.30:1 Typ.
- Passivated Stainless Steel N-Type Connectors
- Uni-Directional

### APPLICATIONS

- Impedance Matching
- Instrumentation
- Test Setups
- High Power Measurements



Generic photo used for illustration purposes only

<b>Model No.</b>	BW-N20W50+
<b>Case Style</b>	GH1788
<b>Connectors</b>	N-Male to N-Female

**+RoHS Compliant**  
 The +Suffix identifies RoHS Compliance.  
 See our website for methodologies and qualifications

### PRODUCT OVERVIEW

The BW-N20W50+ 20 dB precision fixed attenuator achieves great flatness versus frequency from DC to 18 GHz and handles high power signals up to 50 W. High power handling, excellent VSWR, and precise performance make the BW-N20W50+ ideal for applications including high power measurement, improving matching, test setups, and other functions demanding accurate attenuation and high power capability.

### KEY FEATURES

Feature	Advantages
Wide Frequency Range	DC to 18 GHz frequency range gives the BW-N20W50+ attenuator versatile application functionality.
Excellent VSWR, 1.30 Typ.	Well-matched for 50Ω systems; reduces effects of phase variation.
Flat Attenuation	Accurate performance within ±0.5 dB over the full frequency range.
Rugged Construction	Excellent durability for a long lifetime of use.
Heat Dissipation Fins	Designed to dissipate heat efficiently, the BW-N20W50+ requires no external cooling equipment.
Compact Size (2.65" x 2.65" x 4.5")	Outstanding performance capability and power handling without prohibitive space constraints.



### ELECTRICAL SPECIFICATIONS AT +25°C

Parameter	Condition (GHz)	Min.	Typ.	Max.	Unit
Frequency Range	-	DC	-	18	GHz
Attenuation	DC - 18	19.0	20.0	21.0	dB
VSWR	IN	-	-	1.45	:1
	OUT	-	-	1.5	
Input Power <sup>1</sup>	DC - 18	-	-	50	W

1. Max. power at +25°C ambient, derate linearly to 20 W at +100°C. Peak power 500 W Max. 5 μsec. pulse width, 100 Hz PRF, input N-Male. 5 W max. at N-Female.

### ABSOLUTE MAXIMUM RATINGS<sup>2</sup>

Parameter	Ratings
Operating Temperature <sup>3</sup>	-55°C to +100°C
Storage Temperature	-55°C to +100°C

2. Permanent damage may occur if any of these limits are exceeded.  
3. +85°C with output into open or short.

### ELECTRICAL SCHEMATIC

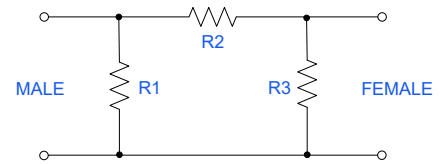



COAXIAL

# Precision Fixed Attenuator

## BW-N20W50+

Mini-Circuits

50Ω 50 W 20 dB DC to 18 GHz N-Male to N-Female

### OUTLINE DRAWING

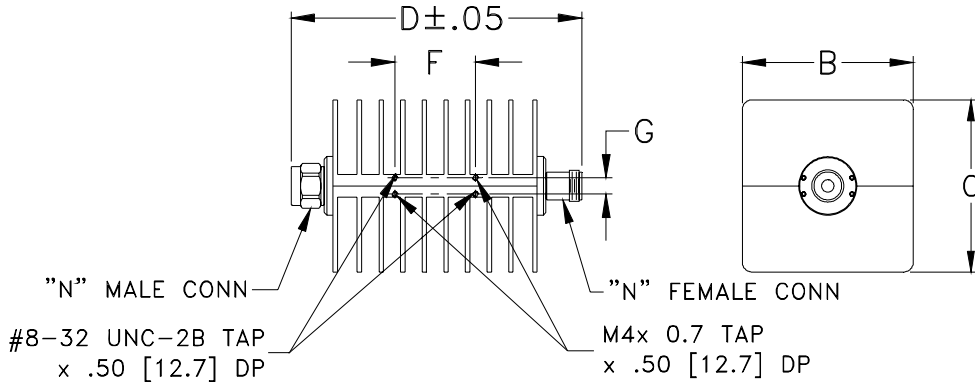

### OUTLINE DIMENSIONS (Inch/mm)

B	C	D	E	F	G	wt.
2.65	2.65	4.50	--	1.25	.25	grams
67.31	67.31	114.30	--	31.75	6.35	720.0



COAXIAL

# Precision Fixed Attenuator

# BW-N20W50+

Mini-Circuits

50Ω 50 W 20 dB DC to 18 GHz N-Male to N-Female

### TYPICAL PERFORMANCE DATA AND CHARTS

Frequency (GHz)	Attenuation (dB)	VSWR (:1)	
		IN	OUT
0.01	20.22	1.01	1.02
2.0	20.43	1.06	1.02
4.0	20.42	1.13	1.05
6.0	20.35	1.05	1.09
8.0	20.23	1.12	1.26
10.0	19.99	1.22	1.17
12.4	20.03	1.29	1.21
14.0	19.81	1.39	1.18
16.0	19.55	1.15	1.13
18.0	19.36	1.10	1.22

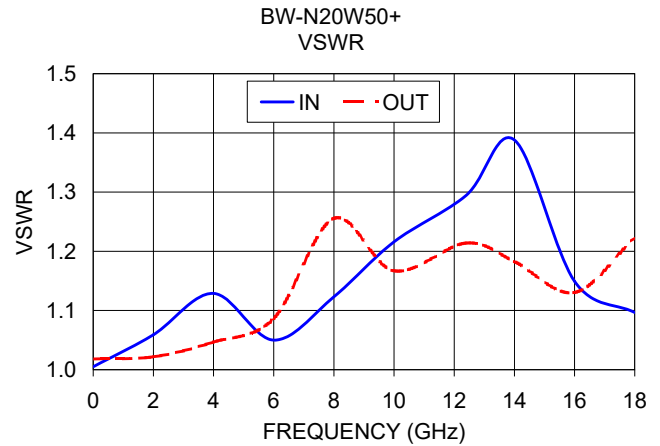
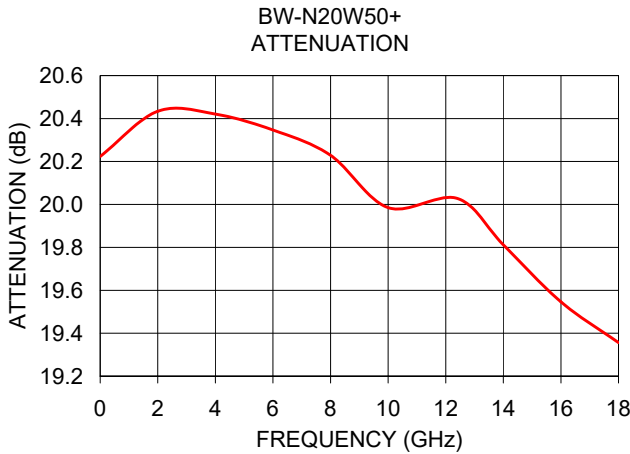

#### NOTES

- A. Performance and quality attributes and conditions not expressly stated in this specification document are intended to be excluded and do not form a part of this specification document.
- B. Electrical specifications and performance data contained in this specification document are based on Mini-Circuits' applicable established test performance criteria and measurement instructions.
- C. The parts covered by this specification document are subject to Mini-Circuits' standard limited warranty and terms and conditions (collectively, "Standard Terms"); Purchasers of this part are entitled to the rights and benefits contained therein. For a full statement of the standard terms and the exclusive rights and remedies thereunder, please visit Mini-Circuits' website at [www.minicircuits.com/terms/viewterm.html](http://www.minicircuits.com/terms/viewterm.html)

