

# 1. SPECIFICATION

SD-150

	ITEM	UNIT	SPECIFICATIONS	CONDITION
01	Dimension 尺寸	mm	Φ 38 X 21.2	Refer to attached drawing in details.
02	Input power 輸入功率	mW	10	White noise is applied for 96 hours.
03	Max. Input power 額定輸入最大功率	mW	Max.20	at room temperature for 60s on and 120s off for 10 cycles.
04	Impedance 交流阻抗	Ω	150 ±20%	at 1KHz /1V.
05	S.P.L 音壓位準 Sound pressure level	dB	96 ±3	at 1KHz 60mV with IEC318 coupler.
06	Frequency range 有效頻寬	Hz	300~3400	
07	T.H.D 總諧波失真 Total Harmonics Distortion	%	Max. 10	at 1KHz 10mW

REV NO.

REVISION NOTE

APPROVAL

DATE

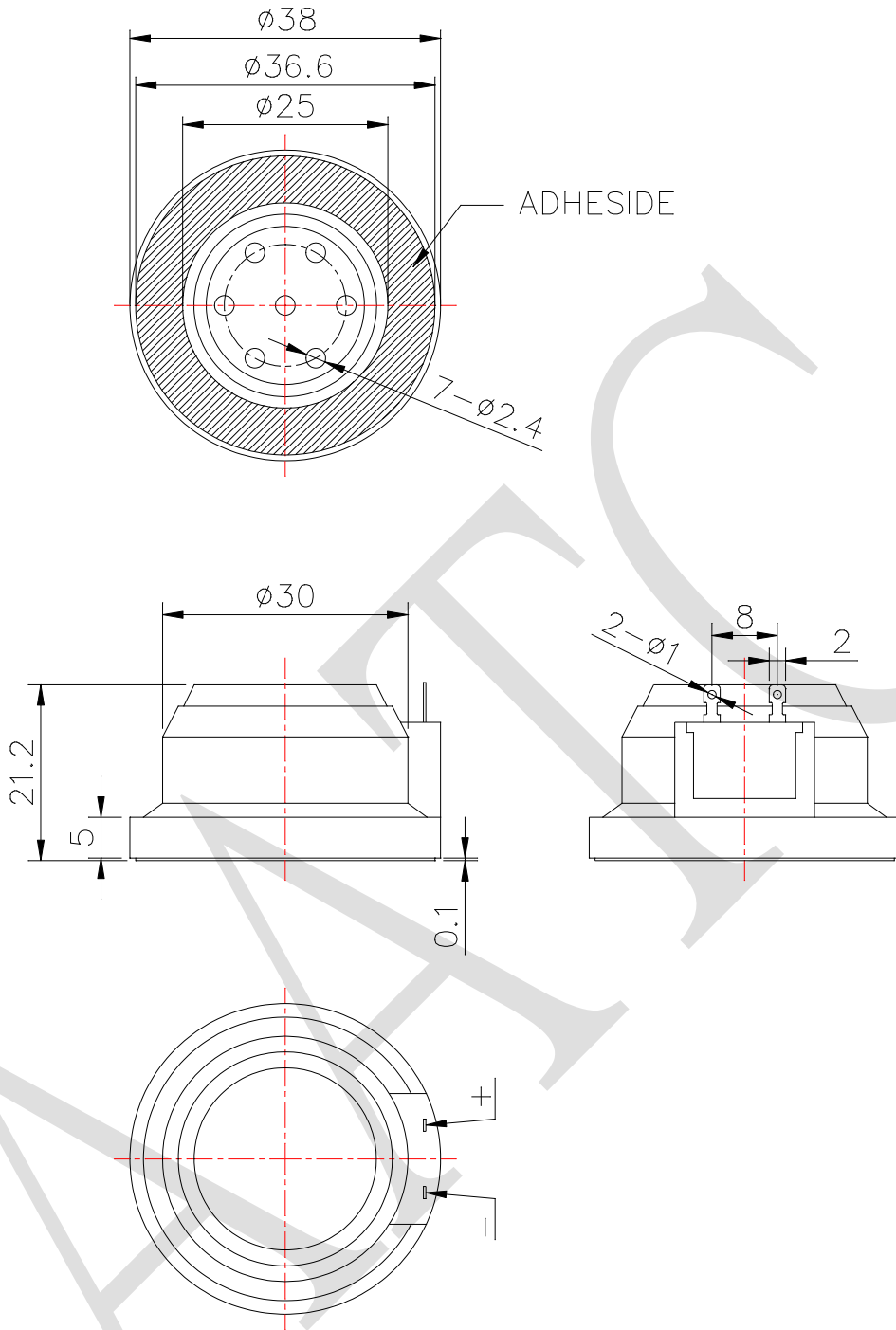

RoHS

TITLE: DYNAMIC SPEAKER

DRAWN: Sunny 2017-12-11

SCALE: 2:1

SHEET: 1:1

PART NO. SD-150

DESIGNED: R&D OF AAT

UNITS: mm

CHECKED:

TOLERANCE  $\pm 0.5$

APPROVAL:

UNLESS OTHERWISE SPECIFIED:

ONE PLACE DECIMAL  $\pm$  \*\*\*

TWO PLACE DECIMAL  $\pm$  \*\*\*

THREE PLACE DECIMAL  $\pm$  \*\*\*

DWG NO. CA-R17121101

1  
REV

MATERIAL: ABS



ADVANCED ACOUSTIC TECHNOLOGY CORPORATION

For more information, please contact AATC.

AATC