

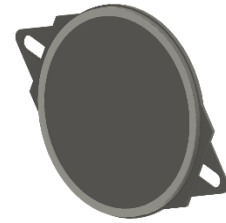

PUIaudio



Data Sheet

AS05008MR-2-F

The AS05008MR-2-F is designed for applications such as hand-held devices, portable devices, and devices that value compact design.

Features:

- 84dB SPL: PDRIVE = 0.1W, distance = 0.1m
- 1.0W continuous dissipation
- 500Hz free-air resonance
- 50mm diameter x 9.0mm dimensions
- Flange for easy implementation

Specifications

Parameters	Values	Units
Rated Input Power	1	Watts
Max Input Power	1.5	Watts
Impedance	8	Ohms
Output SPL (AT 0.8K, 1K, 1.2K, 1.5K Hz; 0.1W, 0.1m)	84±3	dB
Resonant Frequency (at 1V)	500±20%	Hz
Frequency Range (based on -10 dB limits on frequency response graph)	500 ~ 10KHz	Hz
THD (at 1KHz, 0.1W)	< 5%	
Magnet Material	NdFeB	-
Diaphragm Material	PET	-
Weight	15.3	Grams
Buzz, Rattle, etc.	Not be audible at 2.83 V sine wave, 500 ~ 10 KHz	-
Environmental Compliances	ROHS/REACH	-
Polarity	When a positive D.C current is applied to the voice coil terminal marked (+), the diaphragm shall move forward	-
Storage Temperature	-20°C ~ +70°C	°C
Operating Temperature	-20°C ~ +60°C	°C

Measurement Method (0.1m, 0.1W)

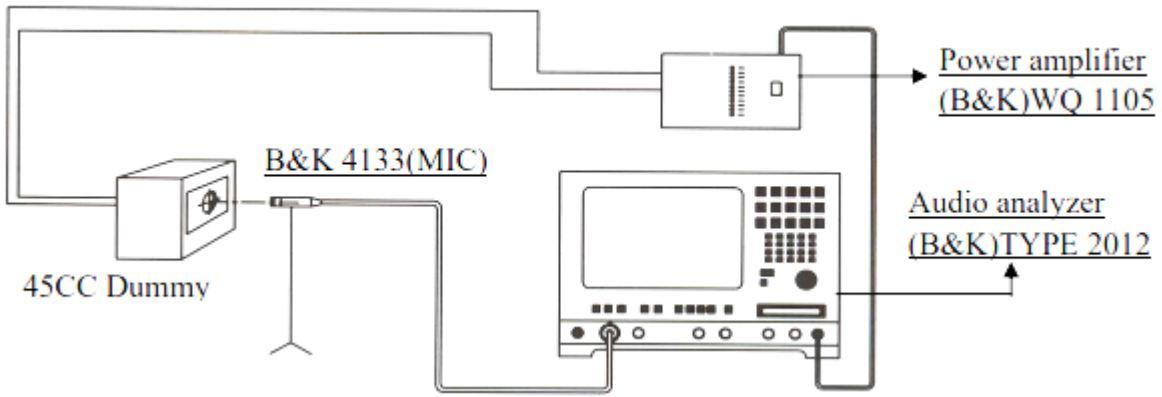

Typical Frequency Response (0.1m, 0.1W)

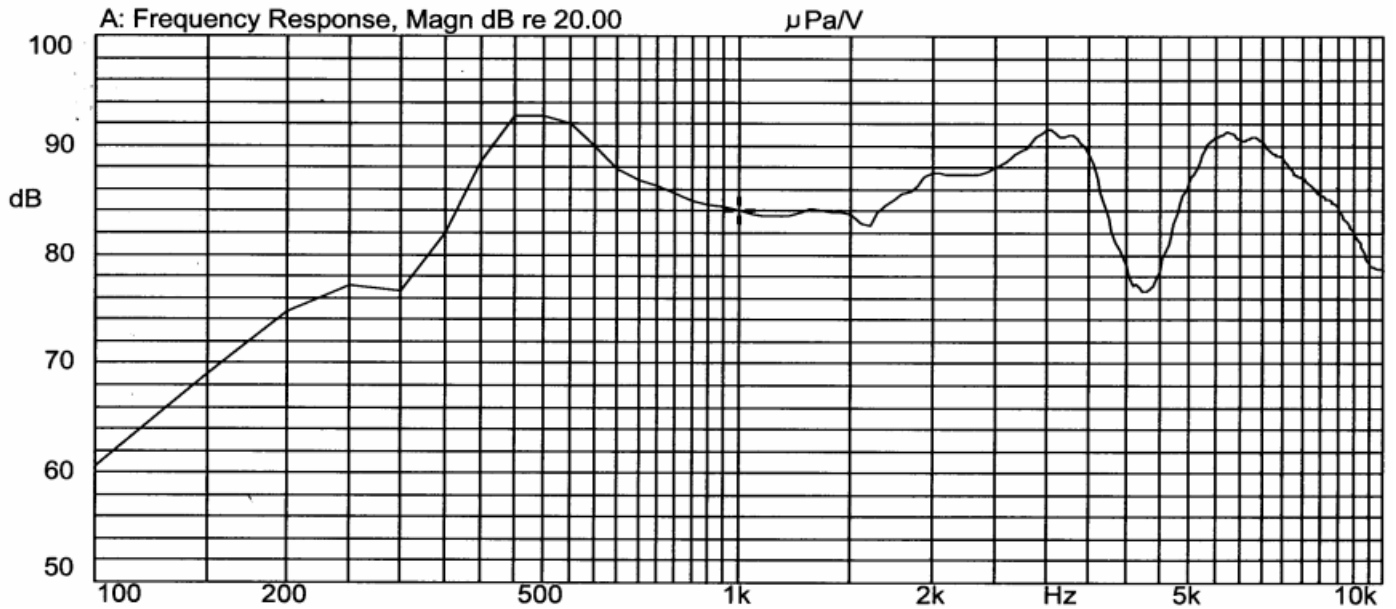

Reliability Testing

Type of Test	Test Specifications
High Temperature Test	24 hours at 60°C, then 6 hours at room temperature
Low Temperature Test	24 hours at -20°C, then 6 hours at room temperature
Humidity Test	+60°C with 90% of RH, for 96 hours, then 6 hours at room temperature
Drop Test	Drop from a height of 1m onto concrete surface.
Load Test	White noise at 1W. / (2.83V) for 96 hours.

After tests, SPL shall not deviate within $\pm 3\text{dB}$ from pre-test measurements.

Dimensions

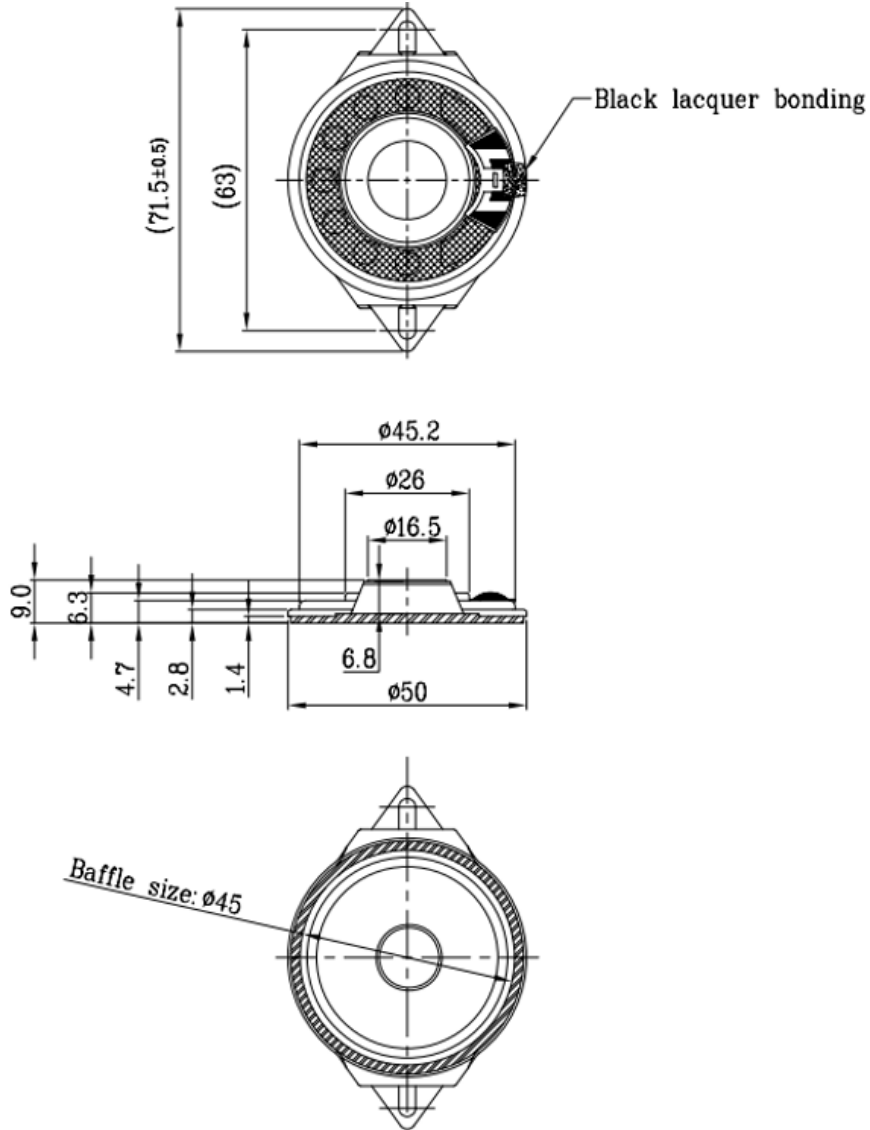

Packaging

1 tray 28 pcs
1 box 20 trays
1 box 560 pcs

Specifications Revisions

Revision	Description	Date	Approved
A	Released from Engineering	11/4/2025	JD

Note:

- Unless otherwise specified:
 - All dimensions are in millimeters.
 - Default tolerances are $\pm 0.5\text{mm}$ and angles are $\pm 3^\circ$.
- Specifications subject to change or withdrawal without notice.