

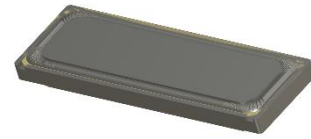

# PUI audio



Data Sheet

AS03404MO-SP34

The **AS03404MO-SP34** is designed for applications such as hand-held devices, portable devices, and devices that value compact design.

## Features:

- 94dB SPL:  $P_{DRIVE} = 1.0W$ , distance = 0.1m, 4cc sealed back-volume
- 2.0W continuous dissipation
- 600Hz free-air resonance
- 34.0mm 11.1mm x 3.5mm dimensions

## Specifications

(Specifications measured with following conditions: ambient temperature;  $15^{\circ}C \leq T_A \leq 35^{\circ}C$ , relative humidity;  $25\% \leq RH_A \leq 75\%$ , according to standard GB/T9396-1996, unless otherwise stated. Judgement Condition: ambient temperature;  $20 \pm 2^{\circ}C$ ; relative humidity;  $63\% \leq RH_A \leq 67\%$ . Product shelf life valid for 12 months.

Parameters	Values	Units
Rated Input Power	2.0	Watts
Maximum Input Power	2.5	Watts
Impedance	$4 \pm 20\%$	Ohms
Sensitivity (SPL) f = ave. 0.8kHz, 1.0kHz, 1.2kHz, 1.5kHz 4cc sealed back-volume $P_{DRIVE} = 1.0W$ , distance = 0.5m $P_{DRIVE} = 1.0W$ , distance = 0.1m, $P_{DRIVE} = 2.0W$ , distance = 0.1m	   80 $\pm$ 3 94 $\pm$ 3 97 $\pm$ 3	   dB
Resonant Frequency ( $f_0$ ) 3cc sealed back-volume	600 $\pm 20\%$	Hz
Frequency Range (-10 dB)	$f_0 \leq f \leq 20,000$	Hz
Total Harmonic Distortion (THD) f = 1 kHz, $P_{DRIVE} = 2.0W$ , 4cc sealed back-volume	$\leq 5$	%
Frame Material	PC + 20% GF	-
Magnet Material	NdFeB	-
Diaphragm Material	Composite	-
Weight	4.8	gm
Buzz, Rattle, etc.	Not audible with $P_{DRIVE} = 2.0W$ , sine wave, 4cc sealed back-volume	-
Polarity	Applying positive dc current to "+" terminal moves diaphragm forward	-
Operating Temperature	$-25 \leq T_o \leq 50$	$^{\circ}C$

## Specifications (Continued)

Storage Temperature	$-40 \leq T_s \leq 85$	°C
Environmental Compliances	ROHS/REACH	-

## Measurement Method (Measured with $P_{DRIVE} = 1.0W$ , distance = 0.5m)

Standard test condition of speaker

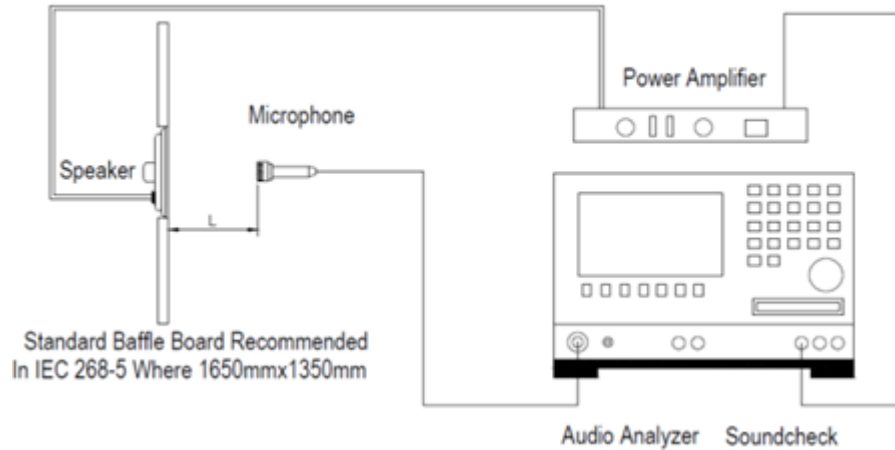

## Typical Frequency Response ( $P_{DRIVE} = 2.0W$ , distance = 0.1m, 3cc sealed back-volume)

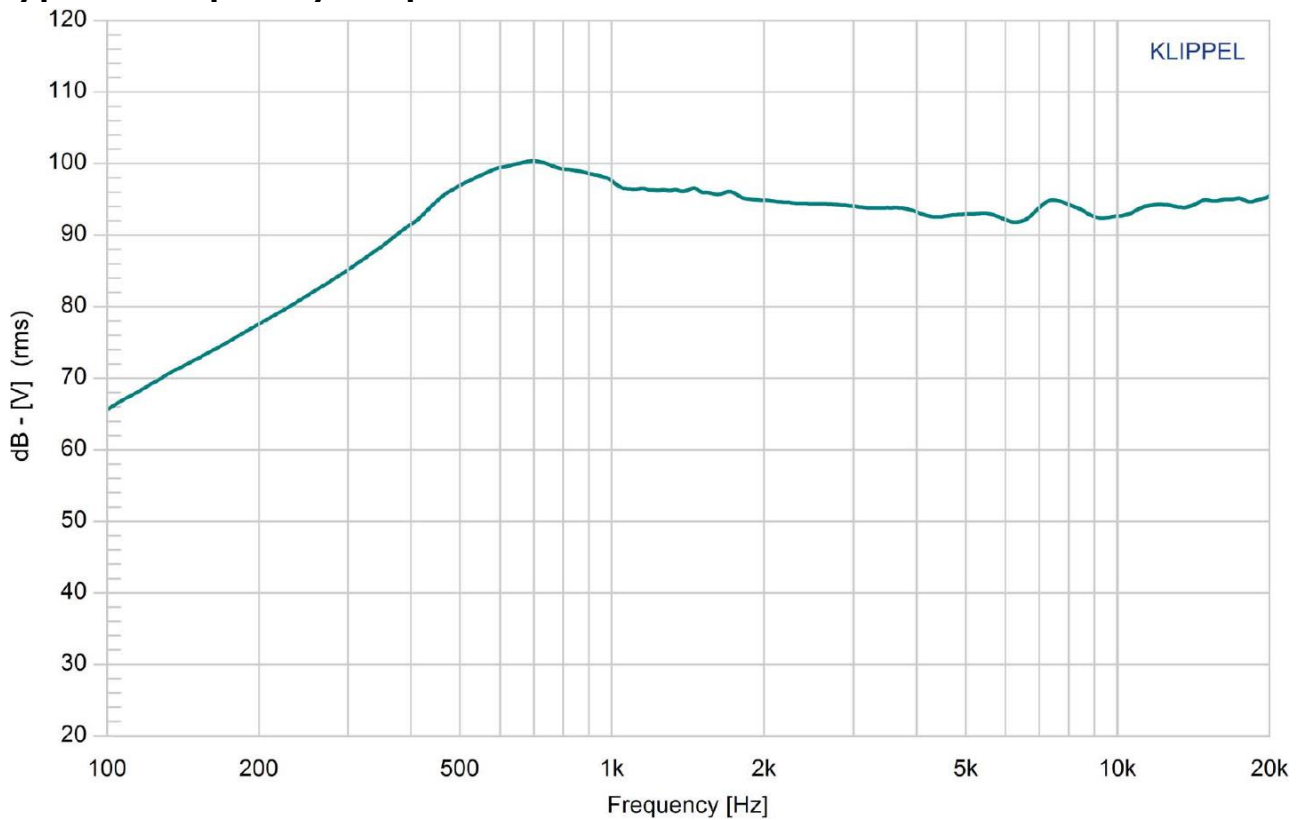

### Typical THD vs. Frequency (P<sub>DRIVE</sub> = 2.0W, 3cc sealed back-volume)

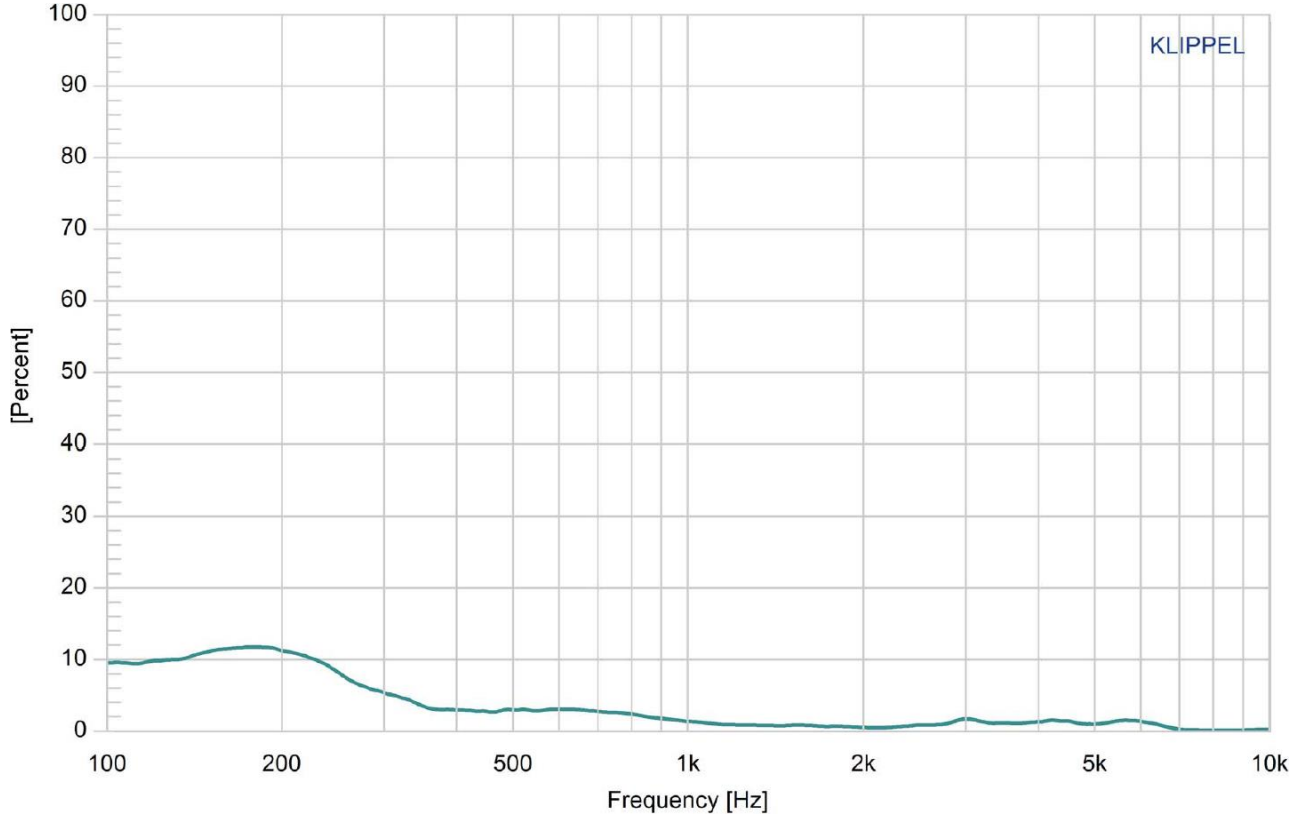

### Typical Impedance Response

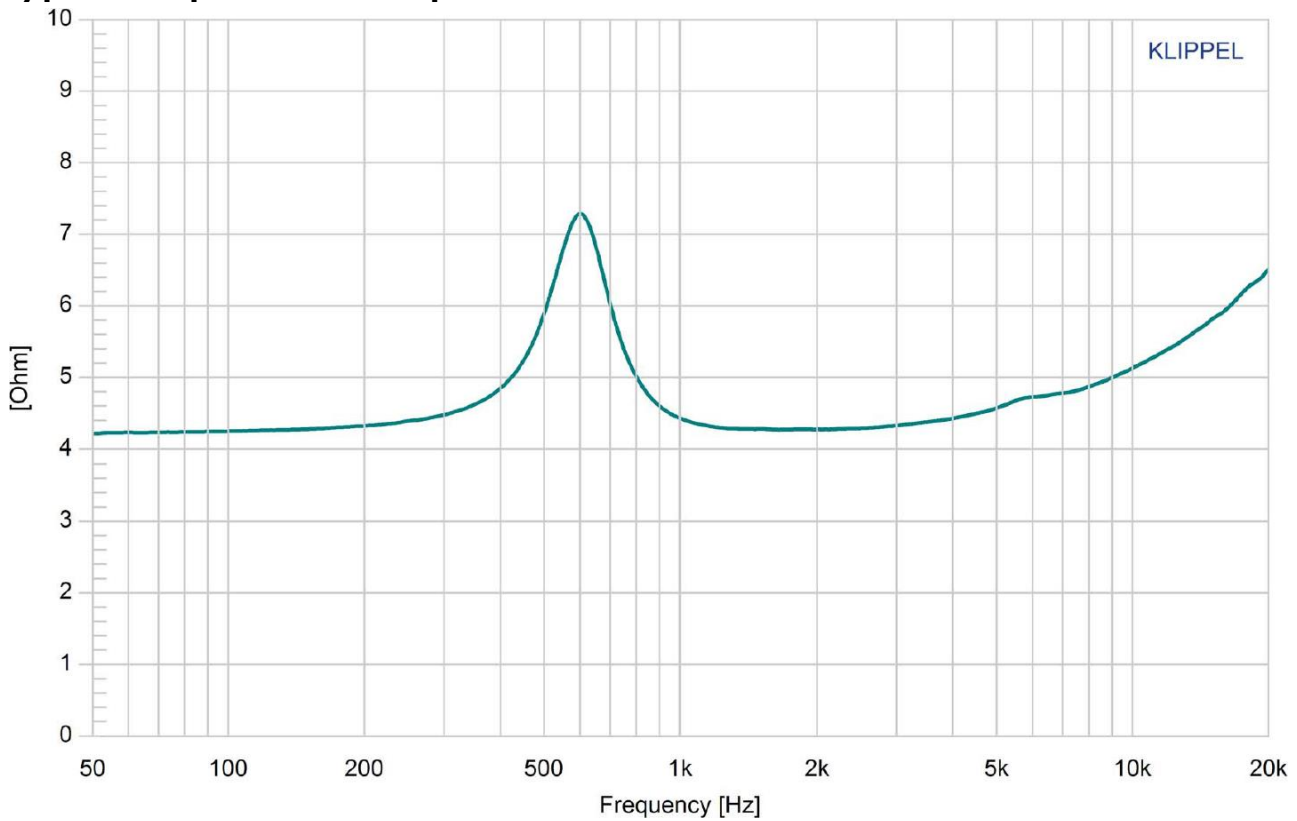

## Reliability Testing

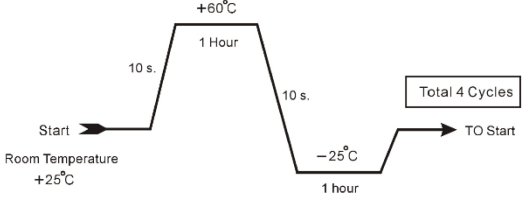
Type of Test	Test Specifications	Judgement
High Temperature Test GB2423.2-81	96 hours at +60°C ± 2°C followed by one hour in normal room temperature	SPL shall not deviate by ±3dB. Resonant frequency shall not deviate by ±50Hz. (compared with pre-test measurement)
Low Temperature Test GB2423.1-81	96 hours at -25°C ± 2°C followed by one hour in normal room temperature	
Humidity Test GB5170.18-87	96 hours at +40°C ± 2°C with relative humidity between 90% and 95% followed by 6 hours in normal room temperature	
Temperature Cycle Testing GB5170.18-87	 <p>The graph shows a temperature cycle starting at Room Temperature +25°C. It ramps up in 10 seconds to +60°C, holds for 1 hour, ramps down in 10 seconds to -25°C, and holds for 1 hour. This cycle repeats 4 times before returning to the start.</p>	SPL shall not deviate by ±4dB. Resonant frequency shall not deviate by ±80Hz. (compared with pre-test measurement)
Vibration Test GB11606.8-89	Frequency 30±15 Hz, Amplitude 1.5 mm for 3 Hours	SPL shall not deviate by ±3dB. (compared with pre-test measurement)
Drop Test GB2423.8-81	75 cm free falling on concrete floor, 10 times.	
Load Test GB/T12060.5-2011	Speaker should not fail after applying 20Hz ~ 20kHz pink noise with HPF rated power input (RMS), 96 hours.	

## Dimensions (All dimensions in mm; tolerance is +0.5mm, unless otherwise stated.)

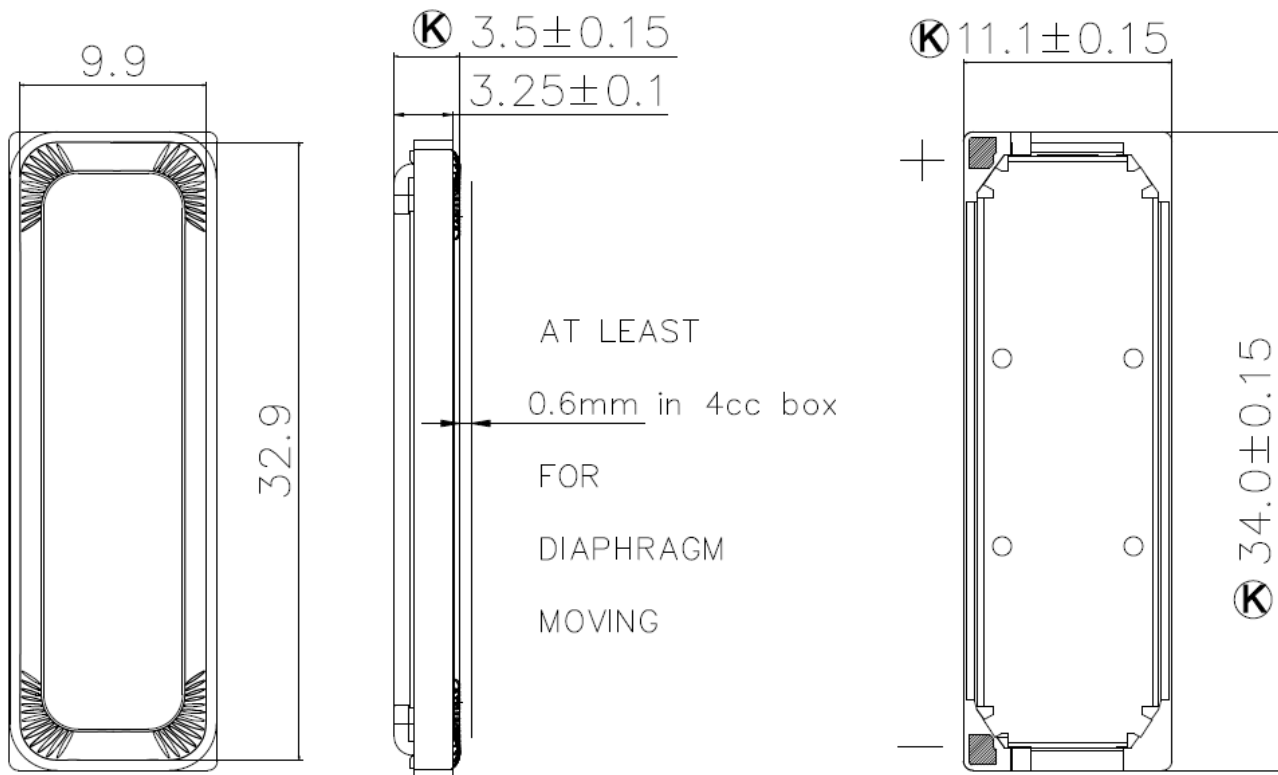

## Packaging

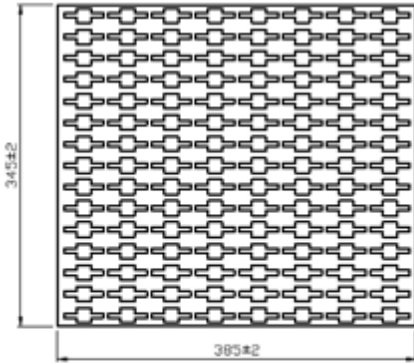

**NOTE**  
120 PCS per Layer  
Total 14 Layer per box  
Total 1680 PCS per box  
41.5\*38.5\*38.5 cm  
HF+ROHS 2

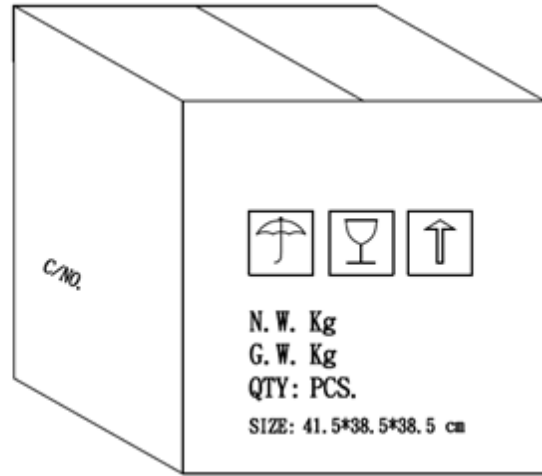
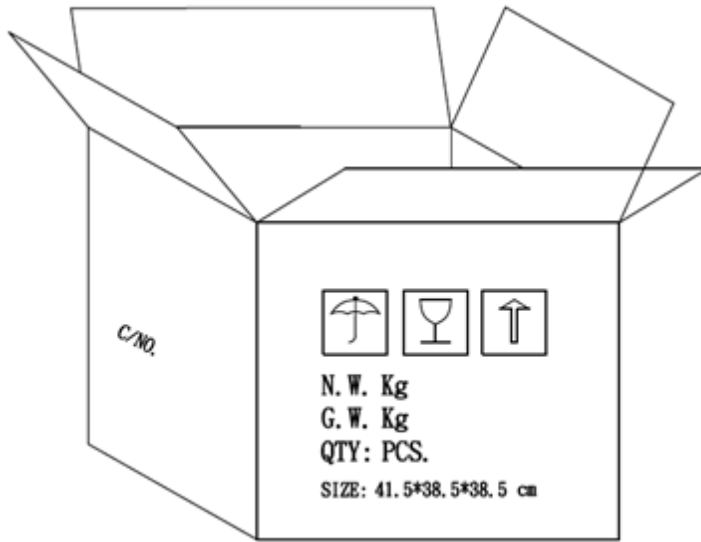

## Measurement & Standard Reference

Abstract from GB/T 9396-1996 and IEC 268-5:1989: methods of measurement for main characteristics of loudspeakers.

### 5.1 Rated sine voltage.

A sinusoidal signal voltage specified by the manufacturer which makes the speaker work continuously in the rated frequency range, without causing electrical or mechanical damage to the speaker. The continuous voltage time is 1 hour.

### 5.2 Rated sine power.

The rated sine power corresponding with the rated sine voltage defined by:  $U_s^2/R$ , where  $U_s$  indicates the rated sin voltage and R indicates the rated impedance of the speaker.

### 5.3 Rated noise power.

The rated sine power corresponding with the rated sine voltage defined by:  $U_n^2/R$ , where  $U_n$  indicates the rated sin voltage and R indicates the rated impedance of the speaker.

#### Specifications Revisions

Revision	Description	Date	Approved
A	Released from Engineering	3/24/2024	KH
B	Corrected SPL in first Features entry on page 1.	03/07/2025	KH

Note:

- Unless otherwise specified:
  - All dimensions are in millimeters.
  - Default tolerances are  $\pm 0.5\text{mm}$  and angles are  $\pm 3^\circ$ , unless otherwise specified.
- Specifications subject to change or withdrawal without notice.