

SERPAC WM094Ri

ELECTRONIC ENCLOSURES

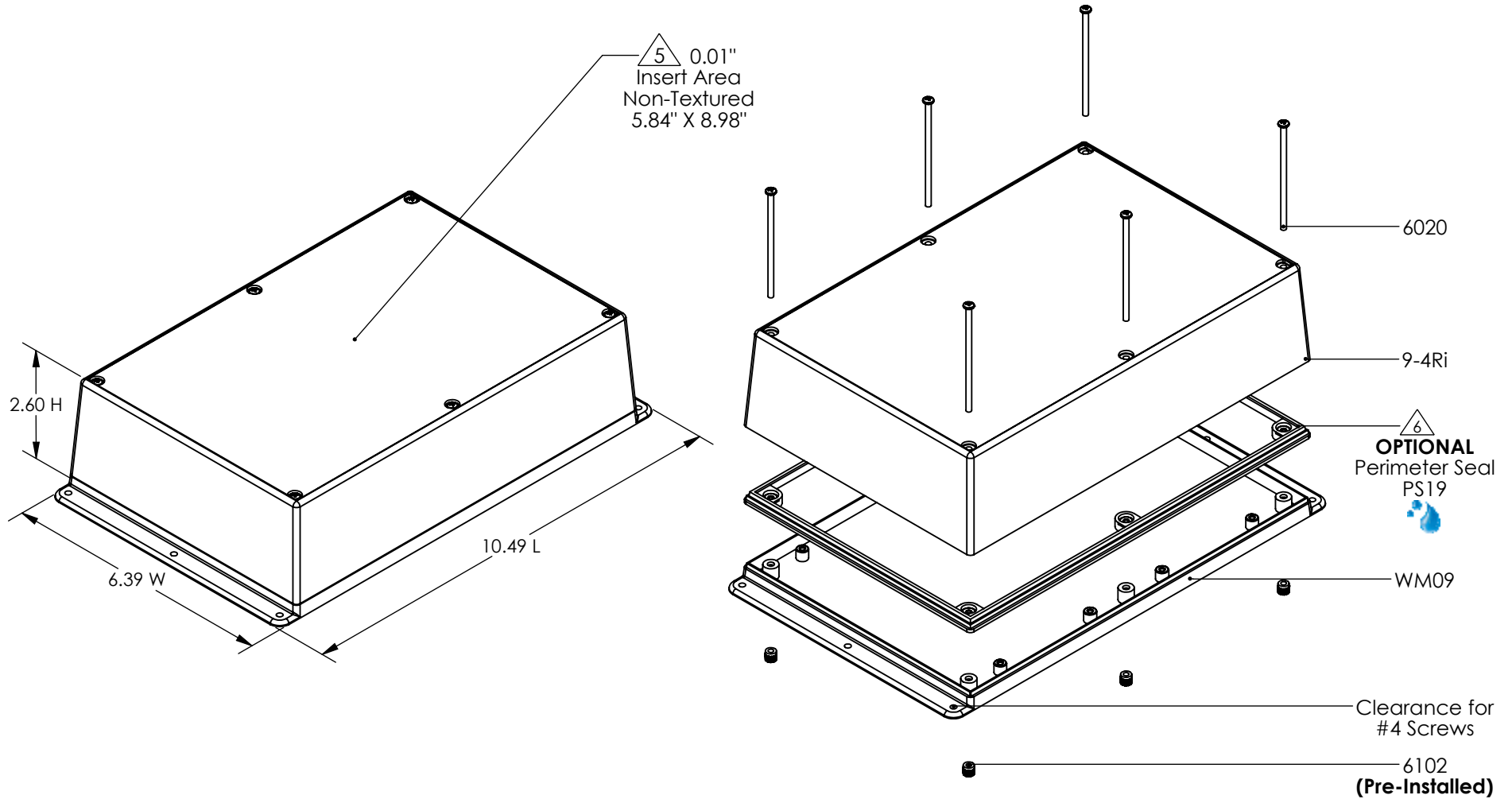

PART NO.	DESCRIPTION (Included)	ACCESSORIES (Optional)	
9-4Ri	Top	PART NO.	DESCRIPTION
WM09	Wall Mount Bottom	PS19	Waterproof Perimeter Seal
6020	4-40 x 2 1/2" Screw (6)	1040	2AA Battery Holder
6102	4-40 Threaded Inserts (6)	60	Standoff Hole
		61	Standoff Post

Notes: Enclosure weight .77 lb / 349 g

- 1) Enclosure meets or exceeds IP40 and NEMA 1
- 2) Circuit Board drawings see sheet 3.
- 3) All components are RoHS Compliant.
- 4) Material: Top and Bottom ABS.
- 5) Customizable molding areas.
- 6) When used with PS19 the enclosure meets or exceeds IP 67 and NEMA 4X, 12 and 13 MIL-STD-810G 506.5 (.04 lb / 19g)

SERPAC WM094Ri

ELECTRONIC ENCLOSURES

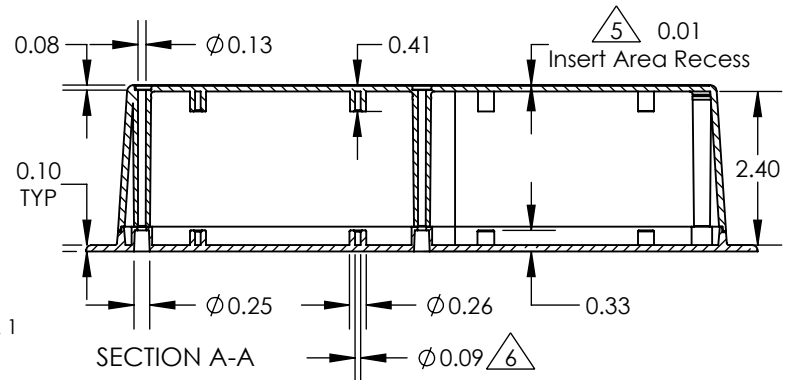
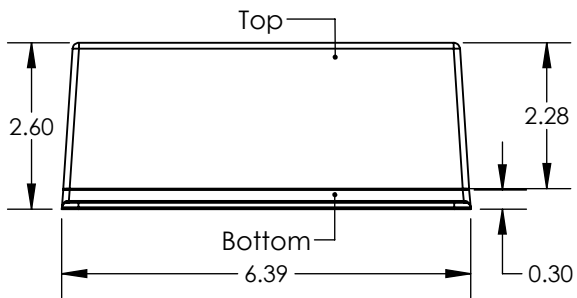
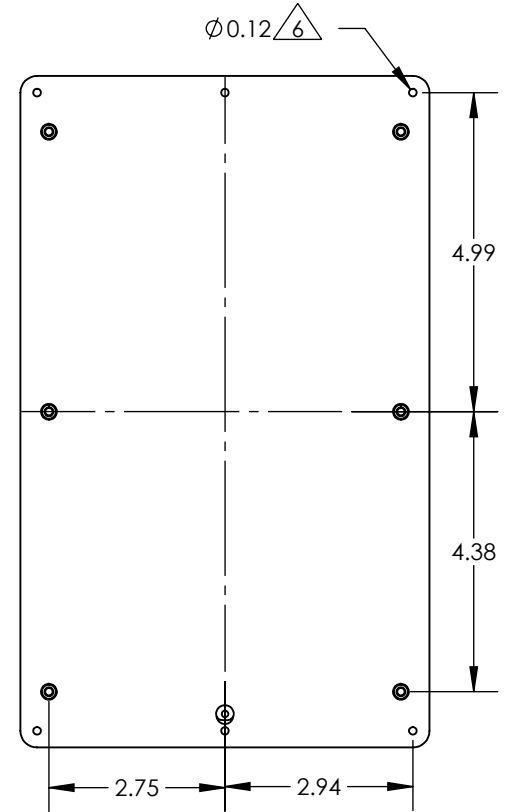
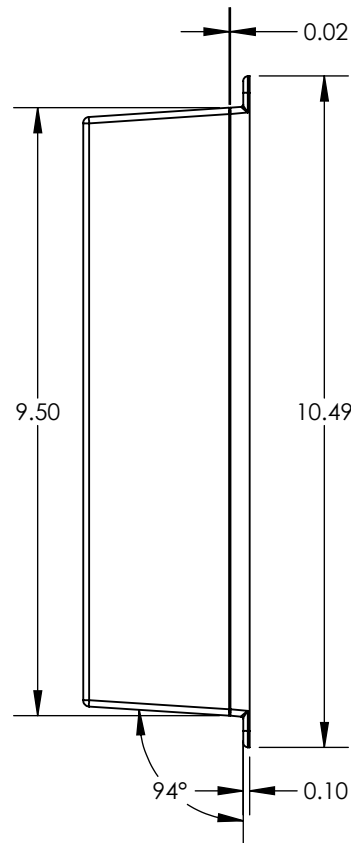
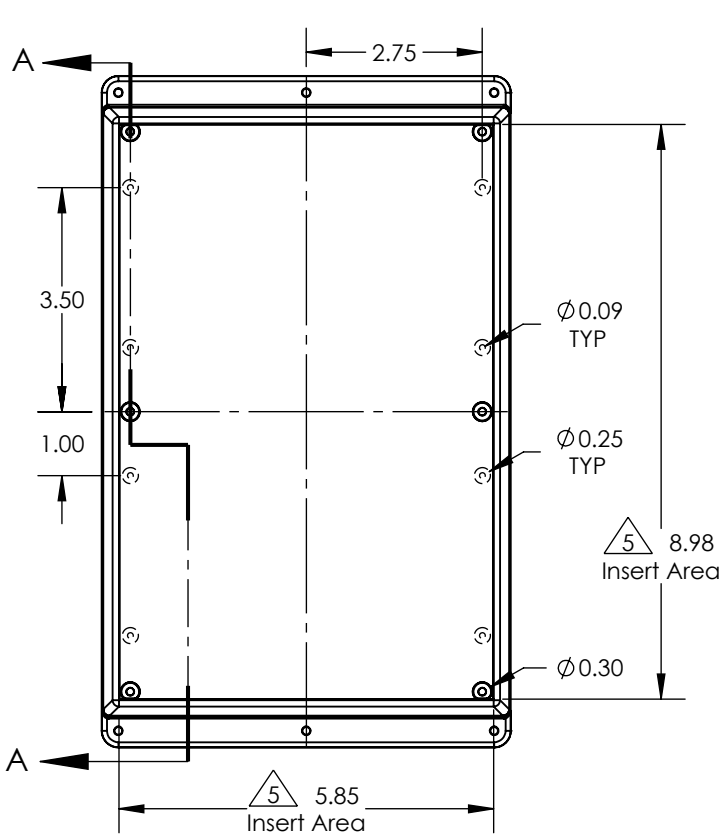

- Notes:
- Enclosure weight .77 lb / 349 g
 - 1) Enclosure meets or exceeds IP40 and NEMA 1
 - 2) Circuit Board drawings see sheet 3.
 - 3) All components are RoHS Compliant.
 - 4) Material: Top and Bottom ABS.
 - 5) Customizable molding areas. $\triangle 5$
 - 6) Accepts #4 self tapping screw. $\triangle 6$
 - 7) When used with PS19 the enclosure meets or exceeds IP 67 and NEMA 4X, 12 and 13 MIL-STD-810G 506.5 (.04 lb / 19g)

SERPAC WM094Ri CIRCUIT BOARD

ELECTRONIC ENCLOSURES

Top & Bottom Option

