

****Not all features are shown in this drawing.**
For more detailed information, please contact
your Fair-Rite representative.

UNCONTROLLED COPY WHEN PRINTED

SIZE	PART NO.	REV.
B	0444184951	~

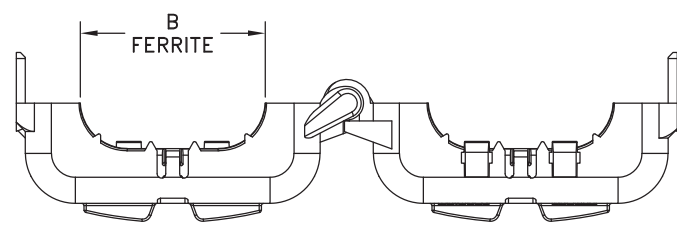
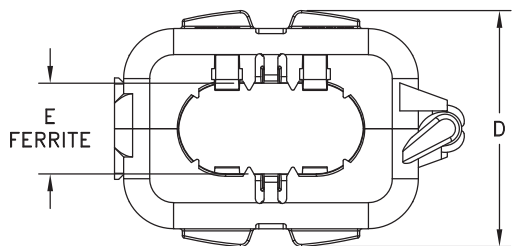
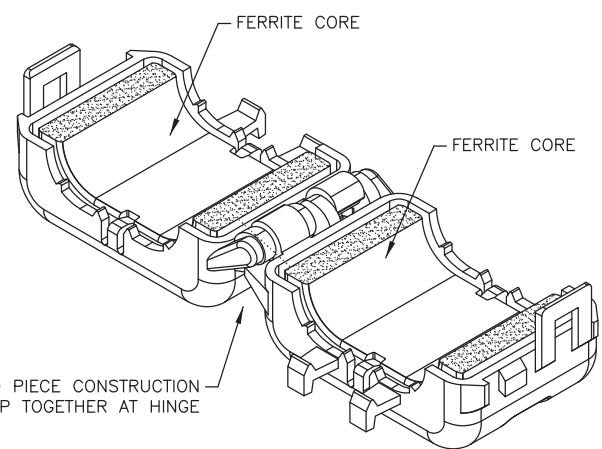
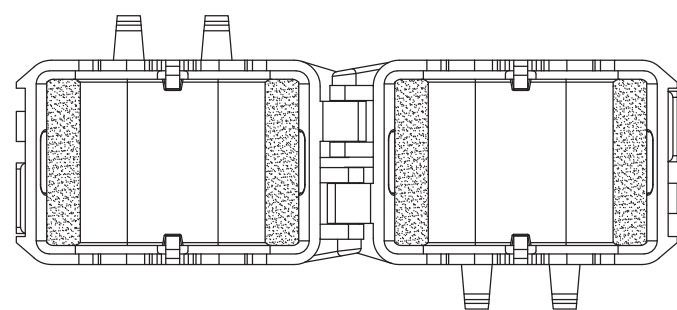
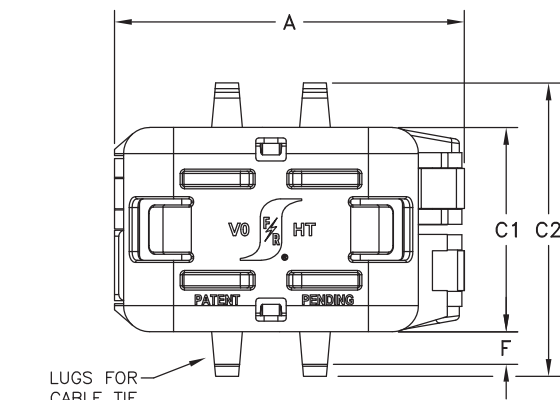

NOTES:

- 1 - COMPONENTS NEEDED FOR ASSEMBLY:
 QTY: 2, FR#2644184955 FR#44 MATERIAL SPLIT CORE
 QTY: 2, FR#0199184955 NYLON PA66 PLASTIC CASE (UL94-V0)

A	B (MIN)	C1	C2
56.90/58.90	30.00	32.8/34.8	47.50/49.50
2.28	1.18	1.33	1.91
D	E (MIN)	F	
38.06/40.06	15.00	4.40/6.40	
1.54	0.59	0.21	

ELECTRICAL SPECIFICATIONS

$\Sigma l/A(\text{mm}^{-1})$	$l_e(\text{mm})$	$A_e(\text{mm}^2)$	$V_e(\text{mm}^3)$	$L_0(\text{nH})/T^2$	IMPEDANCE (OHMS)		$A_L(\text{nH})/T^2$
					25 MHz	100 MHz	100 KHz
0.66	111	168	18596	1.90	TBD Min.	TBD Min.	TBD Min.
					MEASURED ON E4991A/TF16092A	MEASURED WITH 5 TURNS	

BOLD NUMBERS ARE IN MILLIMETERS**, LIGHT NUMBERS ARE IN INCHES.

FAIR-RITE PRODUCTS CORP.					
TITLE ASSEMBLY, SNAP-IT CASE					
DRAWN BY J.CUSTY	DATE 04-22-25	SIZE B	PART NO. 0444184951	REV. ~	
CHKD BY					
APPRVD BY		SCALE NONE	SHEET 1 of 1		