

APPROVAL SHEET

MULTILAYER CERAMIC CAPACITORS

Ultra-small Series (6.3V to 50V)

01005 Size

NP0, X7R & X5R Dielectrics

Halogen Free & RoHS Compliance



*Contents in this sheet are subject to change without prior notice.

Multilayer Ceramic Capacitors

1. INTRODUCTION

MLCC consists of a conducting material and electrodes. To manufacture a chip-type SMT and achieve miniaturization, high density and high efficiency, ceramic condensers are used.

01R5 MLCC is performed by high precision technology achieve high capacitance in unit size and ensure the stability and reliability of products.

2. FEATURES

- a. High capacitance in unit size.
- b. High precision dimensional tolerances.
- c. Suitable used in high-accuracy automatic mounting machine.

3. APPLICATIONS

- a. Miniature microwave module.
- b. Portable equipments (ex. Mobile phone, PDA).
- c. High frequency circuits.

4. HOW TO ORDER

<u>01R5</u>	<u>N</u>	<u>100</u>	<u>C</u>	<u>160</u>	<u>C</u>	<u>I</u>
<u>Size</u>	<u>Dielectric</u>	<u>Capacitance</u>	<u>Tolerance</u>	<u>Rated voltage</u>	<u>Termination</u>	<u>Packaging</u>
Inch (mm) 01R5 = 01005 (0402)	N=NP0 (COG) B=X7R X=X5R	Two significant digits followed by no. of zeros. And R is in place of decimal point. eg.: 0R5=0.5pF 1R0=1.0pF 100=10x10 ⁰ =10pF	A=±0.05pF B=±0.1pF C=±0.25pF D=±0.5pF F=±1% G=±2% J=±5% K=±10% M=±20%	Two significant digits followed by no. of zeros. And R is in place of decimal point. 6R3=6.3 VDC 100=10 VDC 160=16 VDC 250=25 VDC 500=50 VDC	C=Cu/Ni/Sn	T=7" reeled

Multilayer Ceramic Capacitors

5. EXTERNAL DIMENSIONS

Size Inch (mm)	L (mm)	W (mm)	T (mm)/Symbol	M _B (mm)
01R5 (0402)	0.40±0.02	0.20±0.02	0.20±0.02 V	0.07~0.13

* Reflow soldering only.

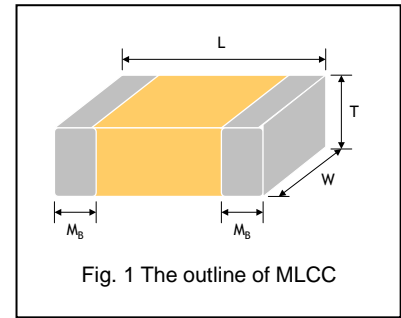

Fig. 1 The outline of MLCC

6. GENERAL ELECTRICAL DATA

Size	01R5		
Dielectric	NP0	X7R	X5R
Capacitance*	0.2pF to 220pF	100pF to 1000pF	1000pF to 0.1μF
Capacitance tolerance**	Cap≤5pF: A (±0.05pF), B (±0.1pF), C (±0.25pF) 5pF<Cap<10pF ^{#1} : A (±0.05pF), B (±0.1pF), C (±0.25pF), D (±0.5pF) Cap≥10pF: F (±1%), G (±2%), J (±5%)		
Rated voltage (WVDC)	16V, 25V, 50V	10V	4V, 6.3V, 10V
DF / Q ^{#1}	Cap<30pF, Q≥400+20C Cap≥30pF, Q≥1000	≤5 %	≤10 %
Insulation resistance at U _r	≥10GΩ or RxC≥500Ω*F whichever is less		
Operating temperature	-55 to +125°C	-55 to +125°C	-55 to +85°C
Capacitance change	±30ppm		±15%
Termination	Ni/Sn (lead-free termination)		

#1: 5pF<Cap<10pF products need to check with sales if it can supply A (±0.05pF).

* Measured at 30~70% related humidity.

NP0: Apply 0.5~5V_{rms}, 1.0MHz±10% at the condition of 25°C ambient temperature.

X7R: Apply 1.0±0.2V_{rms}, 1.0kHz±10%, at 25°C ambient temperature.

X5R: Apply 0.5±0.2V_{rms} or 1.0±0.2V_{rms}^{#2}, 1.0kHz±10%, at the condition of 25°C ambient temperature.

** Preconditioning for Class II MLCC: Perform a heat treatment at 150±10°C for 1 hour, then leave in ambient condition for 24±2 hours before measurement.

#2: Please refer to "RELIABILITY TEST CONDITIONS AND REQUIREMENTS" for detail

Multilayer Ceramic Capacitors

7. CAPACITANCE RANGE

SIZE		01R5		
DIELECTRIC		NP0		
RATED VOLTAGE (VDC)		16	25	50
Capacitance	0.2pF (0R2)	V	V	V
	0.3pF (0R3)	V	V	V
	0.4pF (0R4)	V	V	V
	0.5pF (0R5)	V	V	V
	1.0pF (1R0)	V	V	V
	1.5pF (1R5)	V	V	V
	2.0pF (2R0)	V	V	V
	3.0pF (3R0)	V	V	V
	4.0pF (4R0)	V	V	V
	5.0pF (5R0)	V	V	V
	6.0pF (6R0)	V	V	V
	7.0pF (7R0)	V	V	V
	8.0pF (8R0)	V	V	V
	9.0pF (9R0)	V	V	V
	10pF (100)	V	V	V
	12pF (120)	V	V	V
	15pF (150)	V	V	V
	18pF (180)	V	V	V
	22pF (220)	V	V	V
	27pF (270)	V	V	V
	33pF (330)	V	V	V
	39pF (390)	V	V	V
47pF (470)	V	V	V	
56pF (560)	V	V	V	
68pF (680)	V	V	V	
82pF (820)	V	V	V	
100pF (101)	V	V	V	
120pF (121)	V	V	V	
150pF (151)	V	V	V	
180pF (181)	V	V	V	
220pF (221)	V	V	V	

SIZE		01R5	
DIELECTRIC		X7R	
RATED VOLTAGE (VDC)		10	
Capacitance	100pF (101)	V	V
	150pF (151)	V	V
	220pF (221)	V	V
	330pF (331)	V	V
	470pF (471)	V	V
	1,000pF (102)	V	V

SIZE		01R5	
DIELECTRIC		X5R	
RATED VOLTAGE (VDC)		6.3	10
Capacitance	1,000pF (102)	V	V
	1,500pF (152)	V	V
	2,200pF (222)	V	V
	3,300pF (332)	V	V
	4,700pF (472)	V	V
	6,800pF (682)	V	V
	0.010μF (103)	V	V
	0.015μF (153)	V	V
	0.022μF (223)	V	V
	0.033μF (333)	V	V
	0.047μF (473)	V	V
	0.068μF (683)	V	V
	0.10μF (104)	V	V

1. The letter in cell is expressed the symbol of product thickness.
2. For more information about products with special capacitance or other data, please contact WTC local representative.

8. PACKAGING DIMENSION AND QUANTITY

Size	Thickness (mm)/Symbol	Paper tape	
		7" reel	13" reel
01R5 (0402)	0.20±0.02 V	20,000	-

Unit: pieces

Multilayer Ceramic Capacitors

9. RELIABILITY TEST CONDITIONS AND REQUIREMENTS

No.	Item	Test Condition	Requirements																		
1.	Visual and Mechanical	---	* No remarkable defect. * Dimensions to conform to individual specification sheet.																		
2.	Capacitance	*Test temp.: Room Temperature. Class I: NP0 Cap≤1000pF, 0.5~5Vrms, 1MHz±10% Cap>1000pF, 1.0±0.2Vrms, 1KHz±10% Class II: * 1.0±0.2Vrms, 1KHz±10%: X7R & X5R(≥10V) & 01R5X103≤6.3V & 01R5X104≤10V * 0.5±0.2Vrms, 1KHz±10% X5R(≤6.3V); Excluding 01R5X103≤6.3V & 01R5X104≤10V * Before initial measurement (Class II only): To apply de-aging at 150°C for 1hr then set for 24±2 hrs at room temp.	* Shall not exceed the limits given in the detailed spec. * NP0: Cap≥30pF, Q≥1000; Cap<30pF, Q≥400+20C X7R: ≤5.0 % X5R: ≤10 %																		
3.	Q/ D.F. (Dissipation Factor)	* To apply voltage (≤100V) 250%. * Duration: 1 to 5 sec. * Charge and discharge current less than 50mA.	* No evidence of damage or flash over during test.																		
4.	Dielectric Strength	*Test temp.: Room Temperature. *To apply rated voltage for max. 120 sec.	* NP0, X7R: ≥10GΩ or RxC≥500Ω-F whichever is smaller. X5R: RxC≥50Ω-F																		
5.	Insulation Resistance	*With no electrical load. <table border="1"> <thead> <tr> <th>T.C.</th> <th>Operating Temp</th> </tr> </thead> <tbody> <tr> <td>NP0</td> <td>-55~125°C at 25°C</td> </tr> <tr> <td>X7R</td> <td>-55~125°C at 25°C</td> </tr> <tr> <td>X5R</td> <td>-55~ 85°C at 25°C</td> </tr> </tbody> </table> *Before initial measurement (Class II only): To apply de-aging at 150°C for 1hr then set for 24±2 hrs at room temp. *Measurement voltage for Class II <table border="1"> <tbody> <tr> <td>Cap≤0.01μF: 0.5V</td> </tr> <tr> <td>Cap>0.01μF: 0.2V</td> </tr> </tbody> </table>	T.C.	Operating Temp	NP0	-55~125°C at 25°C	X7R	-55~125°C at 25°C	X5R	-55~ 85°C at 25°C	Cap≤0.01μF: 0.5V	Cap>0.01μF: 0.2V	<table border="1"> <thead> <tr> <th>T.C.</th> <th>Capacitance Change</th> </tr> </thead> <tbody> <tr> <td>NP0</td> <td>Within ±30ppm/°C</td> </tr> <tr> <td>X7R</td> <td>Within ±15%</td> </tr> <tr> <td>X5R</td> <td>Within ±15%</td> </tr> </tbody> </table>	T.C.	Capacitance Change	NP0	Within ±30ppm/°C	X7R	Within ±15%	X5R	Within ±15%
T.C.	Operating Temp																				
NP0	-55~125°C at 25°C																				
X7R	-55~125°C at 25°C																				
X5R	-55~ 85°C at 25°C																				
Cap≤0.01μF: 0.5V																					
Cap>0.01μF: 0.2V																					
T.C.	Capacitance Change																				
NP0	Within ±30ppm/°C																				
X7R	Within ±15%																				
X5R	Within ±15%																				
6.	Temperature Coefficient	* Pressurizing force : 1N * Test time: 10±1 sec.	* No remarkable damage or removal of the terminations.																		
7.	Adhesive Strength of Termination	* Vibration frequency: 10~55 Hz/min. * Total amplitude: 1.5mm * Test time: 6 hrs. (Two hrs each in three mutually perpendicular directions.) * Before initial measurement (Class II only): To apply de-aging at 150°C for 1hr then set for 24±2 hrs at room temp. * Cap./DF(Q) Measurement to be made after de-aging at 150°C for 1hr then set for 24±2 hrs at room temp.	* No remarkable damage. * Cap change and Q/D.F.: To meet initial spec.																		
8.	Vibration Resistance	* Solder temperature: 235±5°C * Dipping time: 2±0.5 sec.	* 95% min. coverage of all metalized area.																		
9.	Solderability	* The middle part of substrate shall be pressurized by means of the pressurizing rod at a rate of about 1 mm per second until the deflection becomes 1 mm and then the pressure shall be maintained for 5±1 sec. * Before initial measurement (Class II only): To apply de-aging at 150°C for 1hr then set for 24±2 hrs at room temp. * Measurement to be made after keeping at room temp. for 24±2 hrs.	* No remarkable damage. * Cap change: NP0: within ±5.0% or ±0.5pF whichever is larger. X7R: within ±12.5% X5R: within ±25.0% (This capacitance change means the change of capacitance under specified flexure of substrate from the capacitance measured before the test.)																		
10.	Bending Test																				

* "Room condition" Temperature: 15 to 35°C, Relative humidity: 25 to 75%, Atmospheric pressure: 86 to 106kPa.

Multilayer Ceramic Capacitors

No.	Item	Test Condition	Requirements															
11.	Resistance to Soldering Heat	<ul style="list-style-type: none"> * Solder temperature: 260±5°C * Dipping time: 10±1 sec * Preheating: 120 to 150°C for 1 minute before immerse the capacitor in a eutectic solder. * Before initial measurement (Class II only): To apply de-aging at 150°C for 1hr then set for 24±2 hrs at room temp. * Cap. / DF(Q) / I.R. Measurement to be made after de-aging at 150°C for 1hr then set for 24±2 hrs at room temp. 	<ul style="list-style-type: none"> * No remarkable damage. * Cap change: NP0: within ±2.5% or ±0.25pF whichever is larger. X7R: within ±7.5% X5R: within ±15.0% Q/D.F., I.R. and dielectric strength: To meet initial requirements. * 25% max. leaching on each edge. 															
12.	Temperature Cycle	<ul style="list-style-type: none"> * Conduct the five cycles according to the temperatures and time. <table border="1"> <thead> <tr> <th>Step</th> <th>Temp. (°C)</th> <th>Time (min.)</th> </tr> </thead> <tbody> <tr> <td>1</td> <td>Min. operating temp. +0/-3</td> <td>30±3</td> </tr> <tr> <td>2</td> <td>Room temp.</td> <td>2~3</td> </tr> <tr> <td>3</td> <td>Max. operating temp. +3/-0</td> <td>30±3</td> </tr> <tr> <td>4</td> <td>Room temp.</td> <td>2~3</td> </tr> </tbody> </table> <ul style="list-style-type: none"> * Before initial measurement (Class II only): To apply de-aging at 150°C for 1hr then set for 24±2 hrs at room temp. * Cap. / DF(Q) / I.R. Measurement to be made after de-aging at 150°C for 1hr then set for 24±2 hrs at room temp. 	Step	Temp. (°C)	Time (min.)	1	Min. operating temp. +0/-3	30±3	2	Room temp.	2~3	3	Max. operating temp. +3/-0	30±3	4	Room temp.	2~3	<ul style="list-style-type: none"> No remarkable damage. * Cap change: NP0: within ±2.5% or ±0.25pF whichever is larger. X7R: within ±7.5% X5R: within ±15.0% * Q/D.F., I.R. and dielectric strength: To meet initial requirements.
Step	Temp. (°C)	Time (min.)																
1	Min. operating temp. +0/-3	30±3																
2	Room temp.	2~3																
3	Max. operating temp. +3/-0	30±3																
4	Room temp.	2~3																
13.	Humidity (Steady State)	<ul style="list-style-type: none"> * Test temp.: 40±2°C * Humidity: 90~95% RH * Test time: 500+24/-0hrs. * Before initial measurement (Class II only): To apply de-aging at 150°C for 1hr then set for 24±2 hrs at room temp. * Cap. / DF(Q) / I.R. Measurement to be made after de-aging at 150°C for 1hr then set for 24±2 hrs at room temp. 	<ul style="list-style-type: none"> * No remarkable damage. * Cap change: NP0: within ±5.0% or ±0.5pF whichever is larger. X7R: within ±12.5% X5R: within ±25.0% * Q/D.F. value: NP0: Cap≥30pF, Q≥350; 10pF≤Cap<30pF, Q≥275+2.5C Cap<10pF; Q≥200+10C X7R: ≤7.5% X5R: ≤20% * I.R.: NP0, X7R: ≥1GΩ or RxC≥50Ω-F whichever is smaller. X5R: RxC≥10Ω-F. 															
14.	Humidity Load (Damp Heat)	<ul style="list-style-type: none"> * Test temp.: 40±2°C * Humidity: 90~95%RH * Test time: 500+24/-0 hrs. * To apply voltage : rated voltage. * Before initial measurement (Class II only): To apply de-aging at 150°C for 1hr then set for 24±2 hrs at room temp. * Cap. / DF(Q) / I.R. Measurement to be made after de-aging at 150°C for 1hr then set for 24±2 hrs at room temp. 	<ul style="list-style-type: none"> * No remarkable damage. * Cap change: NP0: within ±7.5% or ±0.75pF whichever is larger. X7R: within ±15.0% X5R: within ±25.0% * Q/D.F. value: NP0: Cap≥30pF, Q≥200; Cap<30pF; Q≥100+10/3C X7R: ≤7.5% X5R: ≤20% * I.R.: NP0, X7R: ≥500MΩ or RxC≥25Ω-F whichever is smaller. X5R: RxC≥5Ω-F. 															
15.	High Temperature Load (Endurance)	<ul style="list-style-type: none"> * Test temp.: NP0, X7R: 125±3°C X5R: 85±3°C * To apply voltage: (1) NP0, X7R : 200% of rated voltage (2) X5R: 10V : 150 % of rated voltage (104-10V : 100 % of rated voltage) 6.3V : 100 % of rated voltage * Test time: 1000+24/-0 hrs. * Before initial measurement (Class II only): To apply de-aging at 150°C for 1hr then set for 24±2 hrs at room temp. * Cap. / DF(Q) / I.R. Measurement to be made after de-aging at 150°C for 1hr then set for 24±2 hrs at room temp. ** De-rating conditions: 	<ul style="list-style-type: none"> * No remarkable damage. * Cap change: NP0: within ±3.0% or ±0.3pF whichever is larger. X7R: within ±12.5% X5R: within ±25.0% * Q/D.F. value: NP0: Cap≥30pF, Q≥350; 10pF≤Cap<30pF, Q≥275+2.5C Cap<10pF; Q≥200+10C X7R: ≤7.5% X5R: ≤20% * I.R.: NP0, X7R: ≥1GΩ or RxC≥50Ω-F whichever is smaller. X5R: RxC≥10Ω-F. 															

* "Room condition" Temperature: 15 to 35°C, Relative humidity: 25 to 75%, Atmospheric pressure: 86 to 106kPa.

Multilayer Ceramic Capacitors

APPENDIXES

▣ Tape & reel dimensions

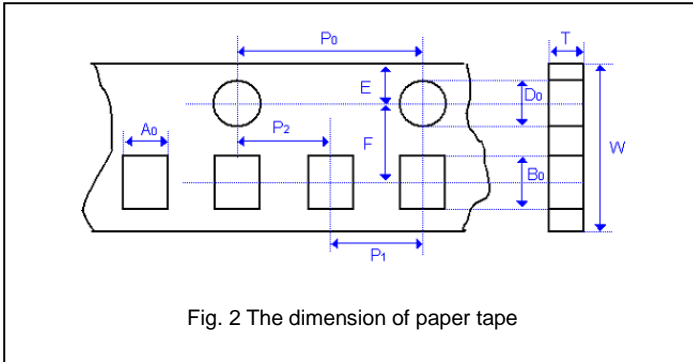

Fig. 2 The dimension of paper tape

Size	01R5
Thickness	V
A ₀	0.25 +/-0.05
B ₀	0.45 +/-0.05
T	≤ 0.50
K ₀	-
W	8.00 +/-0.30
P ₀	4.00 +/-0.10
10xP ₀	40.00 +/-0.10
P ₁	2.00 +/-0.05
P ₂	2.00 +/-0.05
D ₀	1.50 +0.1/-0
D ₁	-
E	1.75 +/-0.10
F	3.50 +/-0.05

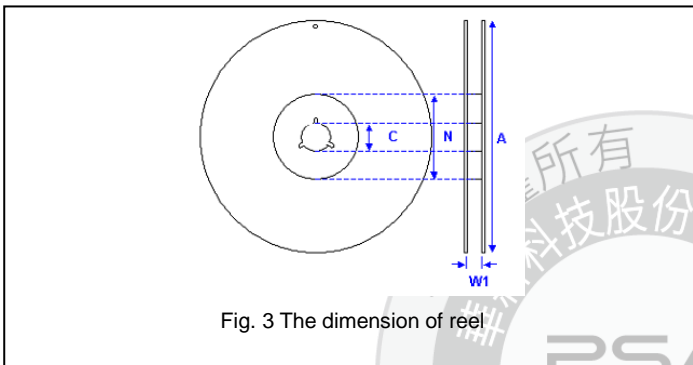
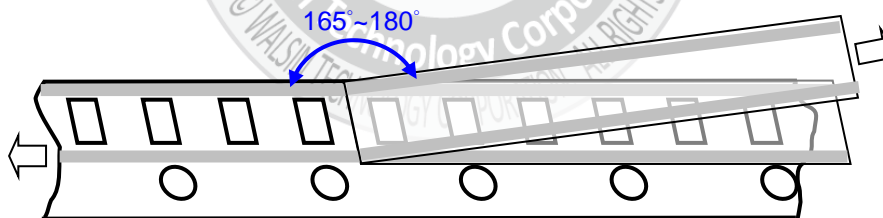

Fig. 3 The dimension of reel

Size	01R5
Reel size	7"
C	13.0±0.5
W ₁	10.0±1.5
A	178.0±2.0
N	60.0+1.0/-0

▣ Peeling force (EIA-481)

Peel-off force should be in the range of 10 grams to 100 grams at a peel-off speed of 300±10 mm/min.



▣ Example of customer label

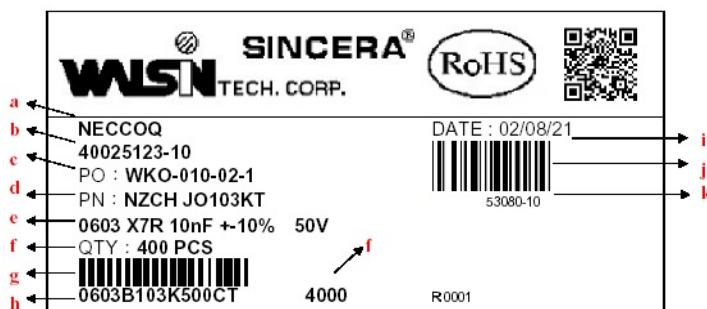

- a. Customer name
- b. WTC order series and item number
- c. Customer P/O
- d. Customer P/N
- e. Description of product
- f. Quantity
- g. Bar code including quantity & WTC P/N or customer
- h. WTC P/N
- i. Shipping date
- j. Order bar code including series and item numbers
- k. Serial number of label

*Customized label is available upon request

Multilayer Ceramic Capacitors

Constructions

No.	Name	NPO	X7R, X5R
①	Ceramic material	CaZrO ₃ based	BaTiO ₃ based
②	Inner electrode		Ni
③	Termination	Inner layer	Cu
④		Middle layer	Ni
⑤		Outer layer	Sn (Matt)

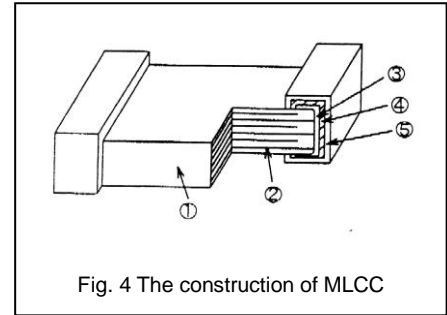

Fig. 4 The construction of MLCC

Storage and handling conditions

- (1) To store products at 5 to 40°C ambient temperature and 20 to 70%. related humidity conditions; MSL Level 1.
- (2) The product is recommended to be used within one year after shipment. Check solderability in case of shelf life extension is needed.

Cautions:

- a. The corrosive gas reacts on the terminal electrodes of capacitors, and results in the poor solderability. Do not store the capacitors in the ambience of corrosive gas (e.g., hydrogen sulfide, sulfur dioxide, chlorine, ammonia gas etc.)
- b. In corrosive atmosphere, solderability might be degraded, and silver migration might occur to cause low reliability.
- c. Due to the dewing by rapid humidity change, or the photochemical change of the terminal electrode by direct sunlight, the solderability and electrical performance may deteriorate. Do not store capacitors under direct sunlight or dewing condition. To store products on the shelf and avoid exposure to moisture.

Recommended soldering conditions

The lead-free termination MLCCs are not only to be used on SMT against lead-free solder paste, but also suitable against lead-containing solder paste. If the optimized solder joint is requested, increasing soldering time, temperature and concentration of N₂ within oven are recommended.

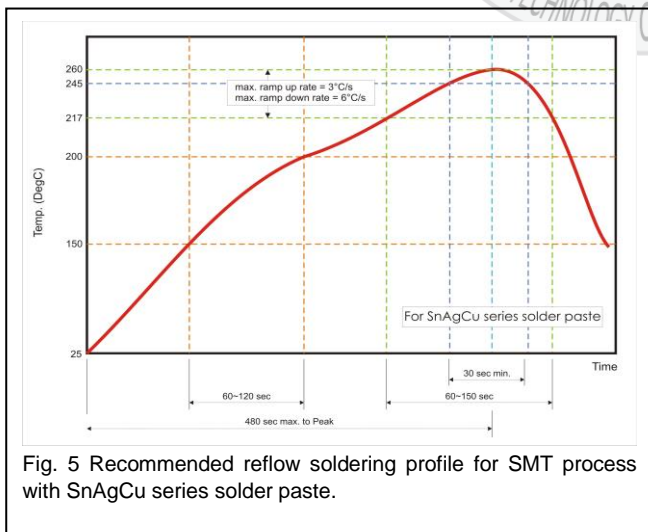

Fig. 5 Recommended reflow soldering profile for SMT process with SnAgCu series solder paste.