

▲ SPST MOMENTARY CIRCUIT

NOTES:

1. ALL DIMENSIONS IN MM [INCH]
2. GENERAL TOLERANCE: X.X=±0.4
X.XX=±0.25
3. CONTACT RATING: 50mA @ 12VDC
4. CONTACT RESISTANCE: 100mΩ MAX.
5. INSULATION RESISTANCE: 100MΩ MIN @ 500VDC.
- ▲ 6. OPERATING FORCE: 260 ± 50gf
7. TRAVEL: 0.15 mm MINIMUM
8. OPERATING TEMPERATURE: -40°C TO + 85°C
9. OPERATING LIFE: 200,000 CYCLES
- ▲ 10. CONTACTS: SILVER
11. ▲ DENOTES CRITICAL PARAMETERS
12. PACKAGE: TAPE AND REEL - 600 PIECES PER REEL

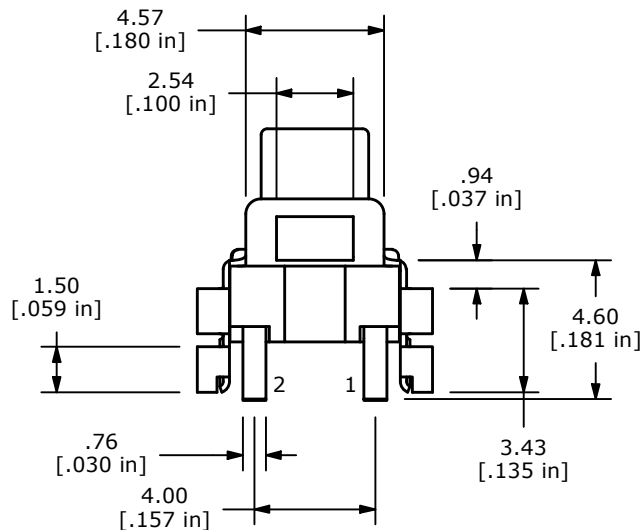
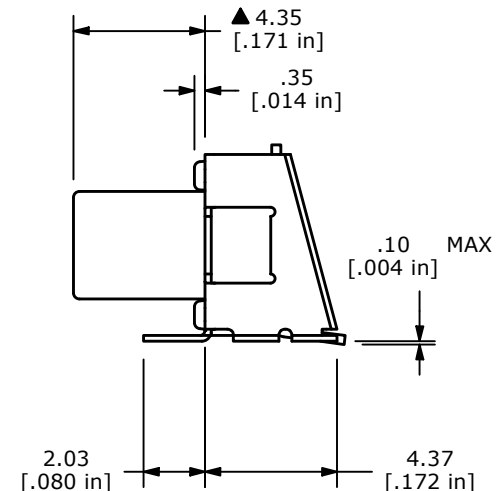
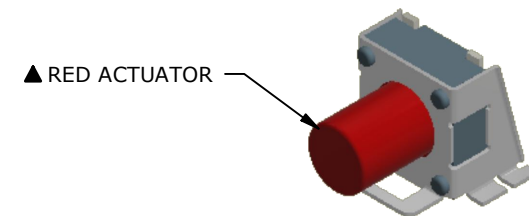
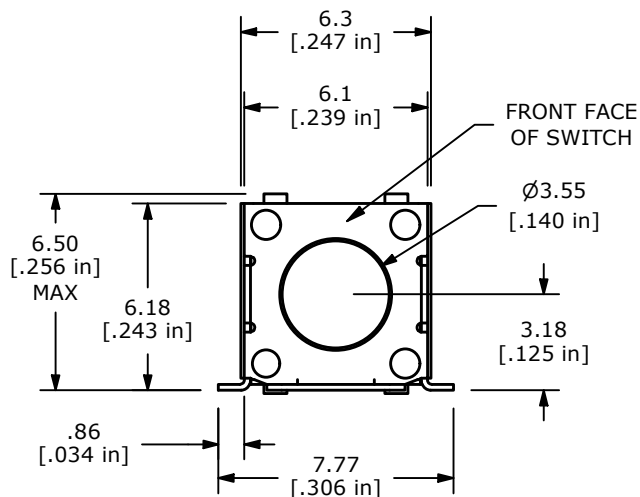

REV	ECO NO	DESCRIPTION	DATE	BY	E-SWITCH®			OBJECT ID	
D	ECO-103901	PRINT UPDATE	01/23/26	JS	TITLE TL3360DF260Q			000017029	
THE INFORMATION CONTAINED IN THIS DOCUMENT IS PROPRIETARY TO E-SWITCH AND IS NOT TO BE COPIED OR TRANSFERRED					SCALE	DATE	DR	DWG	REV
					4:1	6/15/2015	RC	N330007	D