

▲ SPST MOMENTARY CIRCUIT

NOTES:

1. ALL DIMENSIONS IN MM [INCH]
2. GENERAL TOLERANCE: X.X=±0.4
X.XX=±0.25
3. CONTACT RATING: 50mA @ 12VDC
4. CONTACT RESISTANCE: 100mΩ MAX.
5. INSULATION RESISTANCE: 100MΩ MIN @ 500VDC.
- ▲ 6. OPERATING FORCE: 185 ± 50gf
7. TRAVEL: 0.15 mm MINIMUM
8. OPERATING TEMPERATURE: -40°C TO + 85°C
9. OPERATING LIFE: 200,000 CYCLES
- ▲ 10. CONTACTS: SILVER
11. ▲ DENOTES CRITICAL PARAMETERS
12. PACKAGE: IN TAPE AND REEL - 600 PIECES PER REEL

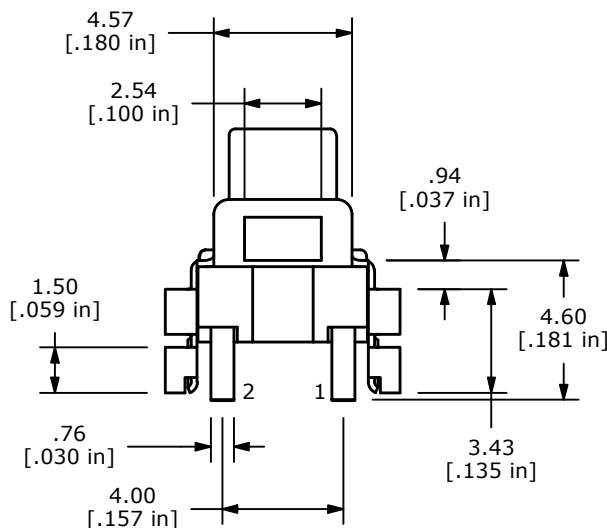
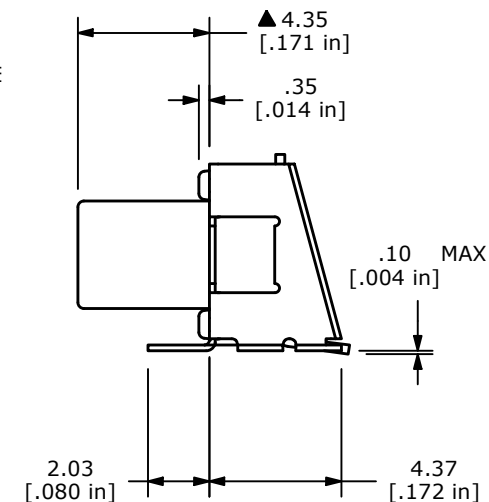
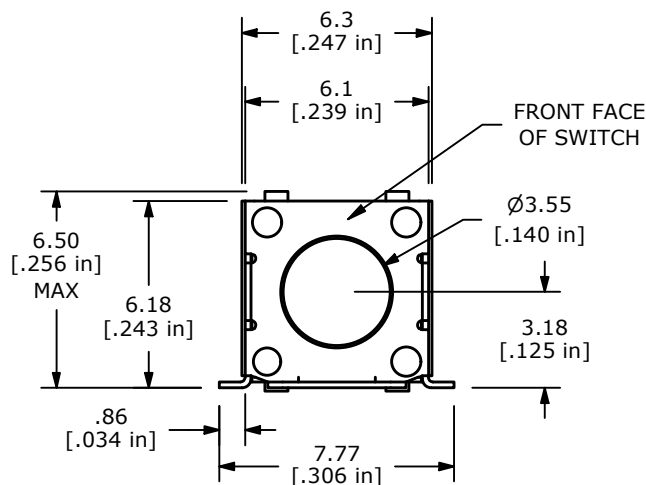
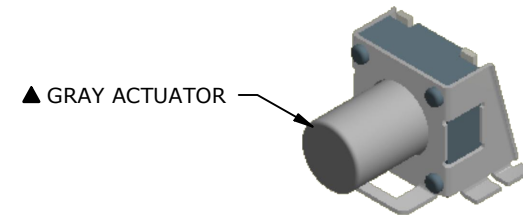

REV	ECO NO	DESCRIPTION	DATE	BY
E	ECO-103901	PRINT UPDATE	01/23/26	JS



OBJECT ID
000017025

TITLE TL3360DF185Q				
SCALE 4:1	DATE 6/15/2015	DR RC	DWG N330003	REV E