

▲ SPST CIRCUIT

NOTES:

1. ALL DIMENSIONS IN MM [INCH]
2. GENERAL TOLERANCE: X.X=±0.4  
X.XX=±0.20
3. CONTACT RATING: 50mA @ 12VDC
4. CONTACT RESISTANCE: 100mΩ MAX.
5. INSULATION RESISTANCE: 100MΩ MIN @ 500VDC.
- ▲ 6. OPERATING FORCE: 185 ± 50gf
7. TRAVEL: 0.15 mm MINIMUM
8. OPERATING TEMPERATURE: -40°C TO + 85°C
- ▲ 9. OPERATING LIFE: 200,000 CYCLES
10. CONTACTS: GOLD
11. ▲ DENOTES CRITICAL PARAMETERS
12. PACKAGE: TAPE AND REEL - 550 PIECES PER REEL

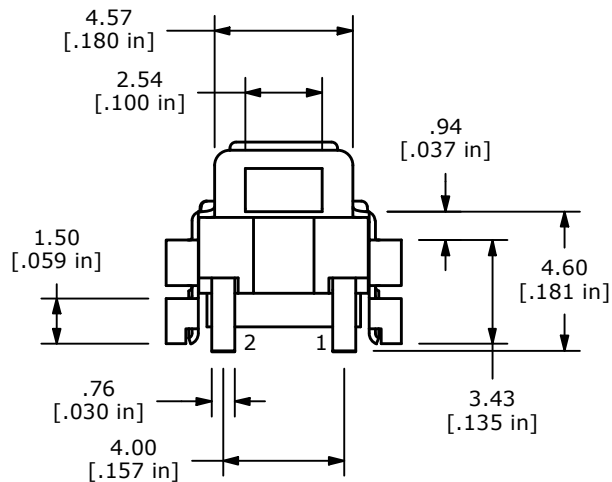
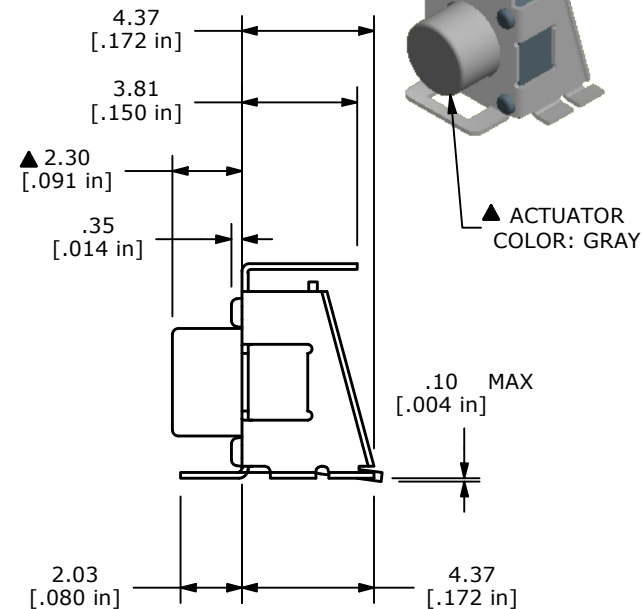
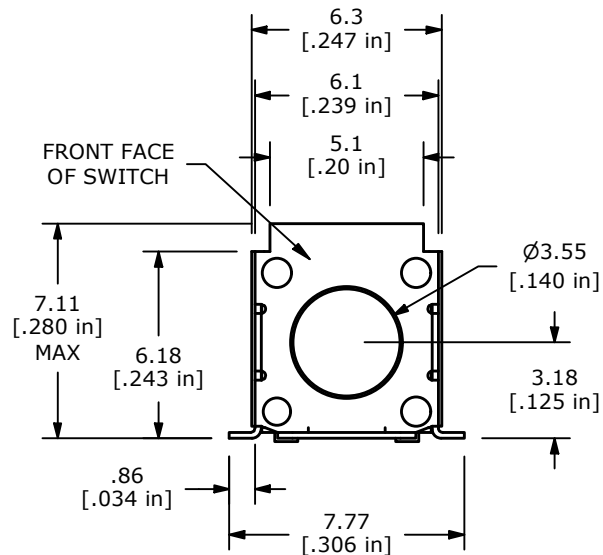

REV	ECO NO	DESCRIPTION	DATE	BY
C	ECO-103901	PRINT UPDATE	01/23/26	JS



OBJECT ID  
100122944

TITLE TL3360AF185KR				
SCALE	DATE	DR	DWG	REV
4:1	10/26/2022	JS	N330008	C