

RECOMMENDED PANEL CUT-OUT

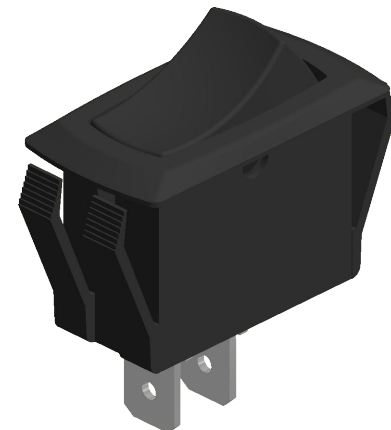

SWITCH FUNCTION	
POS. 1	POS. 2
OFF	ON
NONE	2-1

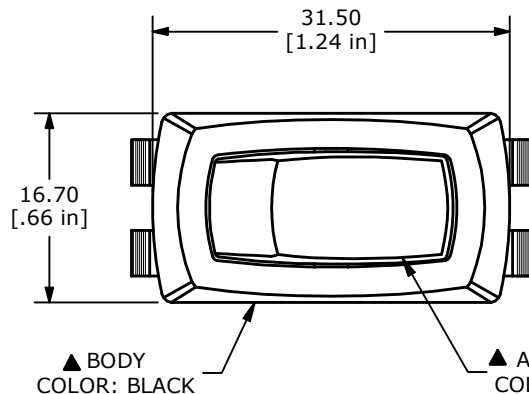
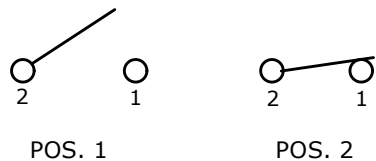

▲ CIRCUIT: SPST  
OFF - ON

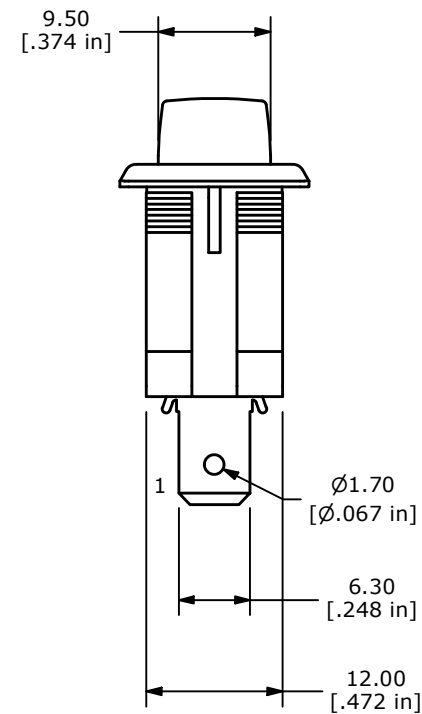
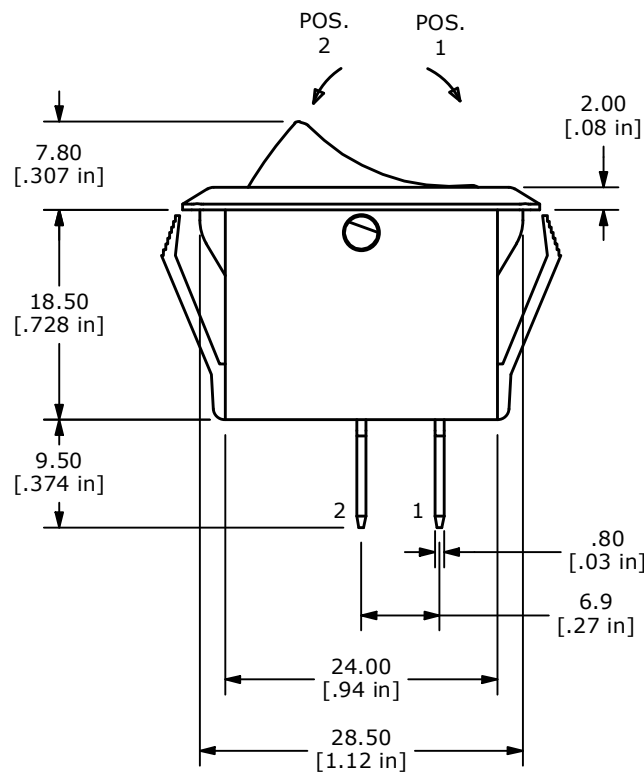

- NOTES:
- ALL DIMENSIONS IN MM [INCH]
  - GENERAL TOLERANCE: X.X = ±0.4  
X.XX = ±0.25
  - TERM. NOS. FOR REF. ONLY
  - RATING: 20A 125VAC [cURus]  
16A 250VAC [cURus]  
1/3HP 125/250VAC [cURus]  
3/4HP 125/250VAC [cURus]
  - ELECTRICAL LIFE: 6,000 CYCLES MIN.
  - CONTACT RESISTANCE: 20mΩ MAX.
  - OPERATING TEMP: 0°C to 105°C [cURus]
  - DIELECTRIC STRENGTH: >1,000V AC 1MIN
  - ▲ DENOTES CRITICAL PARAMETER.
  - LAMP VOLTAGE: NON-ILLUMINATED

REV	ECO NO	DESCRIPTION	DATE	BY
E	ECO-103917	PRINT UPDATE	03/09/26	JS



OBJECT ID  
000000348

TITLE RSC441D1100				
SCALE 3:2	DATE 8/14/2009	DR CAB	DWG 14-RSC441D1100	REV E