

SPST
OFF - ON
▲ SCHEMATIC

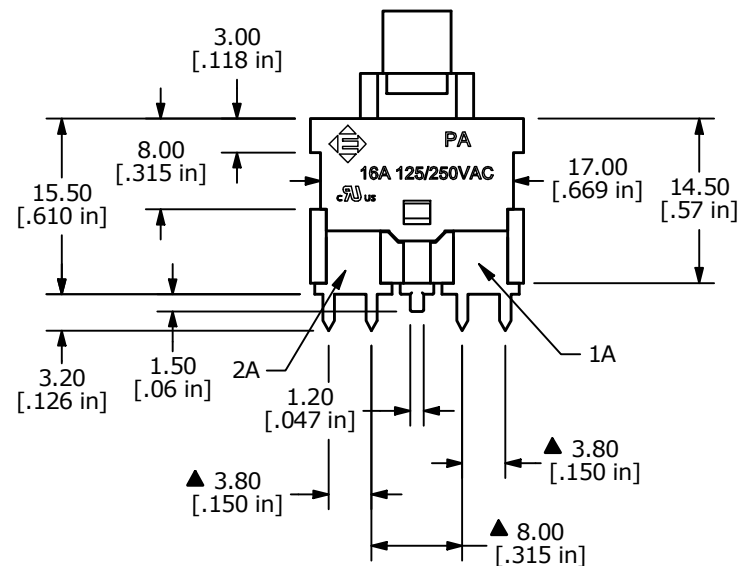
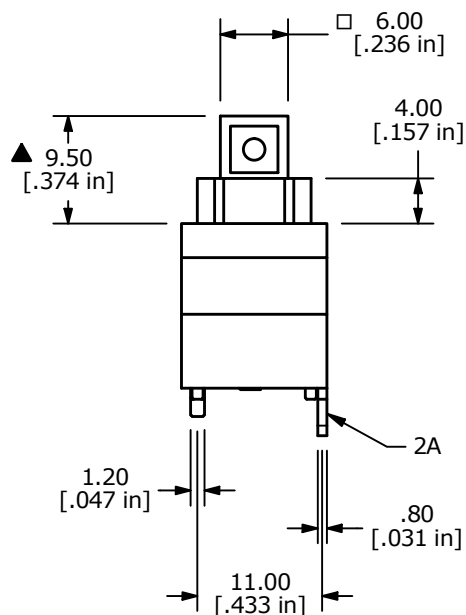

NOTES:

1. ALL DIMENSIONS IN MM [INCH]
2. GENERAL TOLERANCE: X.X = ± 0.4
X.XX = ± 0.25
3. ELECTRICAL LIFE: 6,000 [cURus]
4. CONTACT RESISTANCE: 20 mΩ MAX. INITIAL
5. INSULATION RESISTANCE: 100 MΩ AT 500VDC
6. OPERATING TEMPERATURE: -20°C to +65°C
7. CONTACT RATING: 16A, 125VAC-250VAC, [cURus]
8. DIELECTRIC STRENGTH: 1000V FOR 1 MINUTE
9. ACTUATION FORCE: 500 ± 200 gf
10. TRAVEL: TO LOCK POSITION: 3.0mm
FULL TRAVEL: 5.0mm
11. ▲ DENOTES CRITICAL PARAMETER

REV	ECO NO	DESCRIPTION	DATE	BY
D	ECO-100661	update rating	01/10/22	MW



OBJECT ID
000000269

TITLE PA5F31J		SCALE 3:2	DATE 7/25/2014	DR rc	DWG 14-PA5F31J	REV D
------------------	--	--------------	-------------------	----------	-------------------	----------