

TO-39 NPN SILICON PLANAR TRANSISTOR

General Transistor

ABSOLUTE MAXIMUM RATINGS

DESCRIPTION	SYMBOL	VALUE	UNIT
Collector Emitter Voltage	V_{CEO}	80	V
Collector Base Voltage	V_{CBO}	140	V
Emitter Base Voltage	V_{EBO}	7.0	V
Collector Current Continuous	I_C	1.0	A
Power Dissipation at $T_a=25^\circ\text{C}$ Derate Above 25°C	P_D	0.8 4.6	W mW/°C
Power Dissipation at $T_c=25^\circ\text{C}$ Derate Above 25°C	P_D	5.0 28.6	W mW/°C
Operating and Storage Junction Temperature Range	T_j, T_{stg}	- 65 to +200	°C

THERMAL RESISTANCE

Junction to Case	$R_{th(j-c)}$	16.5	°C/W
Junction to Ambient in free air	$R_{th(j-a)}$	89.5	°C/W

ELECTRICAL CHARACTERISTICS ($T_a=25^\circ\text{C}$ unless specified otherwise)

DESCRIPTION	SYMBOL	TEST CONDITION	MIN	TYP	MAX	UNIT
Collector Emitter Voltage	V_{CEO}	$I_C=1\text{mA}, I_B=0$	80			V
Collector Base Voltage	V_{CBO}	$I_C=100\mu\text{A}, I_E=0$	140			V
Emitter Base Voltage	V_{EBO}	$I_E=100\mu\text{A}, I_C=0$	7.0			V
Collector Cut Off Current	I_{CBO}	$V_{CB}=90\text{V}, I_E=0$			10	nA
		$V_{CB}=90\text{V}, I_E=0, T_a=150^\circ\text{C}$			10	μA
Emitter Cut Off Current	I_{EBO}	$V_{EB}=5\text{V}, I_C=0$			10	nA
			2N3019		2N3020	
DC Current Gain	$*h_{FE}$	$I_C=0.1\text{mA}, V_{CE}=10\text{V}$	>50		30 - 100	
		$I_C=10\text{mA}, V_{CE}=10\text{V}$	>90		40 - 120	
		$I_C=150\text{mA}, V_{CE}=10\text{V}$	100 - 300		40 - 120	
		$I_C=150\text{mA}, V_{CE}=10\text{V}, T_c=-55^\circ\text{C}$	>40		-	
		$I_C=500\text{mA}, V_{CE}=10\text{V}$	>50		30 - 100	
		$I_C=1\text{A}, V_{CE}=10\text{V}$	>15		>15	
			MIN	TYP	MAX	UNIT
Collector Emitter Saturation Voltage	$*V_{CE(sat)}$	$I_C=150\text{mA}, I_B=15\text{mA}$			0.2	V
		$I_C=500\text{mA}, I_B=50\text{mA}$			0.5	V
Base Emitter Saturation Voltage	$*V_{BE(sat)}$	$I_C=150\text{mA}, I_B=15\text{mA}$			1.1	V

*Pulse Test: Pulse Width $\leq 300\text{ms}$, Duty Cycle $\leq 1\%$

2N3019_20Rev_1 040406E

ELECTRICAL CHARACTERISTICS ($T_a=25^{\circ}\text{C}$ unless specified otherwise)

SMALL SIGNAL CHARACTERISTICS

DESCRIPTION	SYMBOL	TEST CONDITION	MIN	TYP	MAX	UNIT
Output Capacitance	C_{ob}	$V_{CB}=10\text{V}, I_E=0, f=1\text{MHz}$			12	pF
Input Capacitance	C_{ib}	$V_{EB}=0.5\text{V}, I_C=0, f=1\text{MHz}$			60	pF
Small Signal Current Gain	h_{fe}	$I_C=1\text{mA}, V_{CE}=5\text{V}, f=1\text{KHz}$				
			2N3019	80		400
		2N3020	30		200	
Collector Rise Time Constant	$r_b'C_C$	$I_E=10\text{mA}, V_{CB}=10\text{V}, f=79.8\text{MHz}$			400	ps
Noise Figure	NF	$I_C=100\mu\text{A}, V_{CE}=10\text{V}, R_S=1\text{K}\Omega, f=1.0\text{KHz}$			4.0	dB

TO-39 Metal Can Package

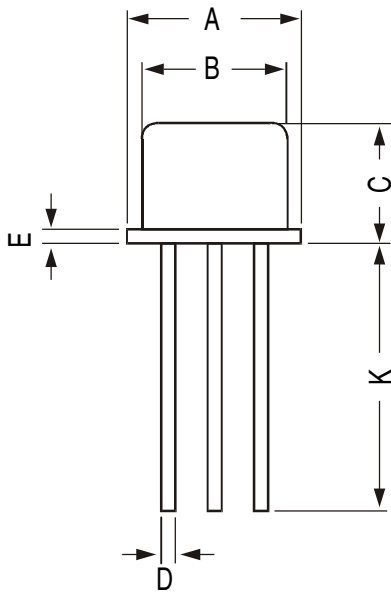

DIM	MIN	MAX
A	8.50	9.39
B	7.74	8.50
C	6.09	6.60
D	0.40	0.53
E	—	0.88
F	2.41	2.66
G	4.82	5.33
H	0.71	0.86
J	0.73	1.02
K	12.70	—
L	42 DEG	48 DEG

All dimensions are in mm

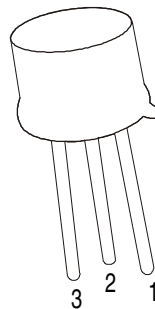
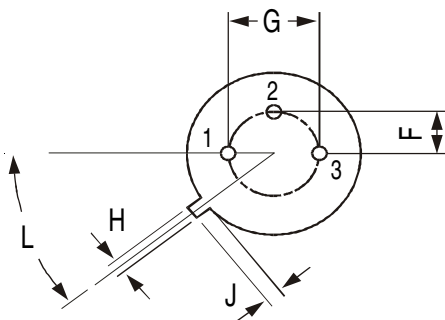

PIN CONFIGURATION

1. EMITTER
2. BASE
3. COLLECTOR

DISCLAIMER NOTICE

Rectron Inc reserves the right to make changes without notice to any product specification herein, to make corrections, modifications, enhancements or other changes. Rectron Inc or anyone on its behalf assumes no responsibility or liability for any errors or inaccuracies. Data sheet specifications and its information contained are intended to provide a product description only. "Typical" parameters which may be included on RECTRON data sheets and/ or specifications can and do vary in different applications and actual performance may vary over time. Rectron Inc does not assume any liability arising out of the application or use of any product or circuit.

Rectron products are not designed, intended or authorized for use in medical, life-saving implant or other applications intended for life-sustaining or other related applications where a failure or malfunction of component or circuitry may directly or indirectly cause injury or threaten a life without expressed written approval of Rectron Inc. Customers using or selling Rectron components for use in such applications do so at their own risk and shall agree to fully indemnify Rectron Inc and its subsidiaries harmless against all claims, damages and expenditures.