

## Bluetooth® Dual Mode Module

### Features

- Bluetooth Classic (BR/EDR) and Low Energy (LE)
- Certified to FCC, ISED, MIC, KCC, SRRC and NCC Radio Regulations
- Radio Equipment Directive (RED) Assessed Radio Module
- Bluetooth 5.0 Certified
- Transparent UART mode for Seamless Serial Data over UART Interface
- Easy to Configure with User Interface (UI) Tool, a Windows®-based Utility or Directly by MCUs
- Firmware can be Upgraded in the Field over UART (Flash version only)
- Integral Chip Antenna (BM78SPPS5MC2/NC2) or External Antenna (BM78SPP05MC2/NC2)
- Integrated Crystal, Internal Voltage Regulator and Matching Circuitry
- Configurable I/O Pins for Control and Status
- Supports Apple® iPod® Accessory Protocol (iAP2), (only BM78SPPx5MC2)
- Supports Bluetooth Low Energy Secure Connections
- Supports Bluetooth Low Energy Data Packet Length Extension
- Small and Compact Surface Mount Module
- Castellated Surface Mount Pads for Easy and Reliable Host PCB Mounting
- Ideal for Portable Battery-Operated Devices
- One LED Driver with 16-Step Brightness Control

### RF/Analog

- Frequency Spectrum: 2.402 GHz to 2.480 GHz
- Receive Sensitivity: -90 dBm (BR/EDR), -92 dBm (LE)
- Class 2 Output Power (+1.5 dBm typical)

### Data Throughput

Data Throughput at 1 Mbps UART Baud Rate:

- BR/EDR: up to 32 Kbytes/s
- LE: up to 7 Kbytes/s

Data Throughput at 115200 bps UART Baud Rate:

- BR/EDR: up to 10 Kbytes/s
- LE: up to 6 Kbytes/s

**FIGURE 1: BM78 MODULE**

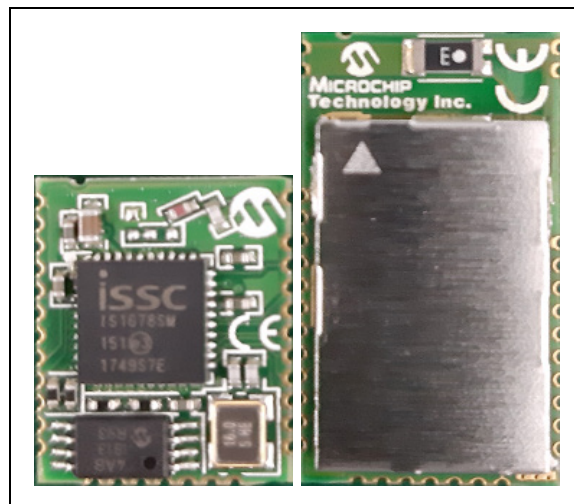

### MAC/Baseband/Higher Layer

- Secure AES128 Encryption
- Bluetooth 3.0: GAP, SPP, SDP, RFCOMM and L2CAP
- Bluetooth Profiles: GAP, GATT, ATT, SMP and L2CAP

### Operating Conditions

- Operating Voltage Range: 3.3V to 4.2V
- Operating Temperature: -20°C to +70°C

### Applications

- Internet of Things (IoT)
- Secure Payment
- Home and Security
- Health and Fitness
- Industrial and Data Logger
- LED Lighting (16 configurations)

## General Description

The BM78 module is a fully certified Bluetooth module for customers to easily add Dual mode Bluetooth wireless capability to their products. The BM78 module is built around Microchip's IS1678 Bluetooth Dual mode SoC, and it is available in ROM-based (BM78SPPX5NC2) and Flash-based (BM78SPPX5MC2) versions. Refer to [Section 9.0 "Ordering Information"](#) for additional information on the BM78 Stock Keeping Units (SKUs).

The BM78 module bridges the customer products to smart phones or tablets for convenient data transfer, control, access to cloud applications and delivering the local connectivity for IoT. The BM78 module supports GAP, SDP, SPP and GATT profiles. Data transfer is achieved through the Bluetooth link by sending or receiving data through Transparent UART mode, making it easy to integrate with any microprocessor or microcontroller with the UART interface. It also enables an easy configuration by using a UI tool, a Windows-based utility, or directly through UART by MCUs.

## 1.0 SYSTEM OVERVIEW

The BM78 module is a fully certified, embedded 2.4 GHz Bluetooth (BR/EDR/LE) wireless module. It includes an on-board Bluetooth stack, power management sub-system, 2.4 GHz transceiver and RF power amplifier. Customers can embed Bluetooth functionality into any application using the BM78 module.

The BM78 module enables rapid product development and faster time to market, and it is designed to provide integrators with the following features:

- Simple integration and programming
- Reduced development time
- Superior wireless module with low-cost system
- Interoperability with Bluetooth host
- Wide range of applications

The BM78SPPS5MC2/NC2 is a complete and fully regulatory certified module with an integral ceramic chip antenna and RF shield. The BM78SPP05MC2/NC2 is a low-cost alternative with RF-out pin (for external antenna) and no RF shield. The integrator is responsible for the antenna, antenna matching and regulatory certifications.

The BM78 module is a small, compact and surface-mounted module with castellated pads for easy and reliable host PCB mounting. It is compatible with standard pick-and-place equipment and can independently maintain a low-power wireless connection. Low-power usage and flexible power management maximize the lifetime of the BM78 module in battery operated devices. A wide operating temperature range enables its applications in indoor and outdoor environments. The following figure illustrates the internal block diagram of the BM78 module.

**FIGURE 1-1: INTERNAL BLOCK DIAGRAM OF BM78 MODULE**

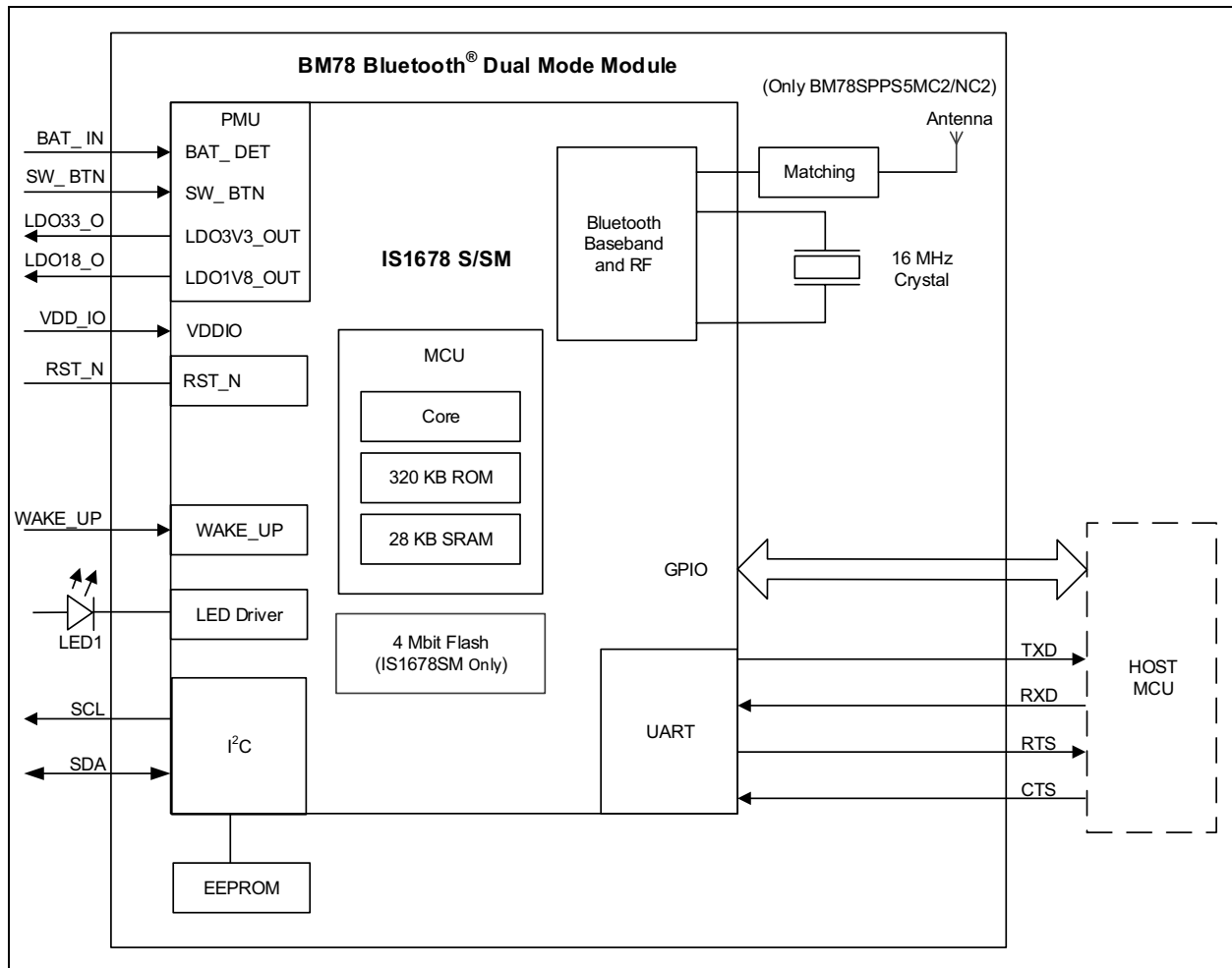

The following table provides a description of the various pins of the BM78SPPx5MC2/NC2 module.

**TABLE 1-1: PIN DESCRIPTION**

S5 Pin	05 Pin	Symbol	Type	Description
1	—	GND	Power	Ground reference
2	—	GND	Power	Ground reference
3	1	GND	Power	Ground reference
4	2	BAT_IN	Power	Battery input (3.3V to 4.2V), Main positive supply input, Connect to 10 $\mu$ F (X5R/X7R) capacitor
5	3	SW_BTN	DI	Software Power Button H: Power On L: Power Off
6	4	LDO33_O	Power	Internal 3.3V LDO output, cannot source more than 50 mA
7	5	VDD_IO	Power	I/O positive supply input, internal use only, do not connect to other devices
8	6	LDO18_O	Power	Internal 1.8V LDO output, internal use only, do not connect to other devices
9	7	WAKE_UP	DI	Wake-up from Sleep mode (active-low) (internal pull-up)
10	8	PMULDO_O	Power	Power Management Unit (PMU) output, internal use only, do not connect to other devices
11	9	P0_4	DO	Status Indication pin, refer to <a href="#">Table 2-4</a>
12	10	P1_5	DO	Status Indication pin, refer to <a href="#">Table 2-4</a>
13	11	P1_2/SCL	DO	I <sup>2</sup> C SCL
14	12	P1_3/SDA	DIO	I <sup>2</sup> C SDA
15	13	P1_7	DIO	Configurable control or Indication pin or UART CTS (input)
16	14	P0_5	DIO	Configurable control or Indication pin
17	15	P0_0	DIO	Configurable control or Indication pin or UART RTS (output)
18	16	P2_0	DI	System configuration pin along with P2_4 and EAN pins, used to set the BM78 module in any one of the following three modes: <ul style="list-style-type: none"> <li>• Application mode (for normal operation)</li> <li>• Test mode (to change EEPROM values)</li> <li>• Write Flash mode (to download the firmware into the module)</li> </ul> Refer to <a href="#">Table 2-1</a> .
19	17	P2_4	DI	System configuration pin along with P2_0 and EAN pins, used to set the BM78 module in any one of the following three modes: <ul style="list-style-type: none"> <li>• Application mode (for normal operation)</li> <li>• Test mode (to change EEPROM values)</li> <li>• Write Flash mode (to download the firmware into the module)</li> </ul> Refer to <a href="#">Table 2-1</a> .

**Legend:** A = Analog D = Digital I = Input O = Output

**TABLE 1-1: PIN DESCRIPTION (CONTINUED)**

S5 Pin	05 Pin	Symbol	Type	Description
20	18	EAN	DI	External address bus negative, System configuration pin along with P2_0 and P2_4 pins used to set the module in any of the three modes: <ul style="list-style-type: none"> <li>• Application mode (for normal operation)</li> <li>• Test mode (to change EEPROM values)</li> <li>• Write Flash mode (to download the firmware into the module)</li> </ul> Refer to Flash/ROM variant type BM78 configuration settings listed in <a href="#">Table 2-1</a> .
21	19	RST_N	DI	Module Reset (active-low) (internal pull-up), Apply a pulse of at least 63 ns
22	20	HCI_RXD	DI	UART data input
23	21	HCI_TXD	DO	UART data output
24	22	P3_1	DIO	Configurable control or Indication pin (Internally pulled up if configured as an input)
25	23	P3_2	DIO	Configurable control or Indication pin (Internally pulled up if configured as an input)
26	24	P3_3	DIO	Configurable control or Indication pin (Internally pulled up if configured as an input)
27	25	P3_4	DIO	Configurable control or Indication pin (Internally pulled up if configured as an input)
28	26	P3_6	DIO	Do not connect
29	27	P3_7	DIO	Configurable control or Indication pin (Internally pulled up if configured as an input)
30	28	LED1	DO	LED driver, connect to LDO33_0
31	29	GND	Power	Ground reference
—	30	BT_RF	AIO	External antenna connection (50 Ohm)
32	—	GND	Power	Ground reference
33	—	GND	Power	Ground reference

**Legend:**      A = Analog      D = Digital      I = Input      O = Output

The following figures illustrate the pin diagrams of the BM78SPPS5MC2/NC2 and BM78SPP05MC2/NC2 modules.

**FIGURE 1-2: BM78SPPS5MC2/NC2 PIN DIAGRAM**

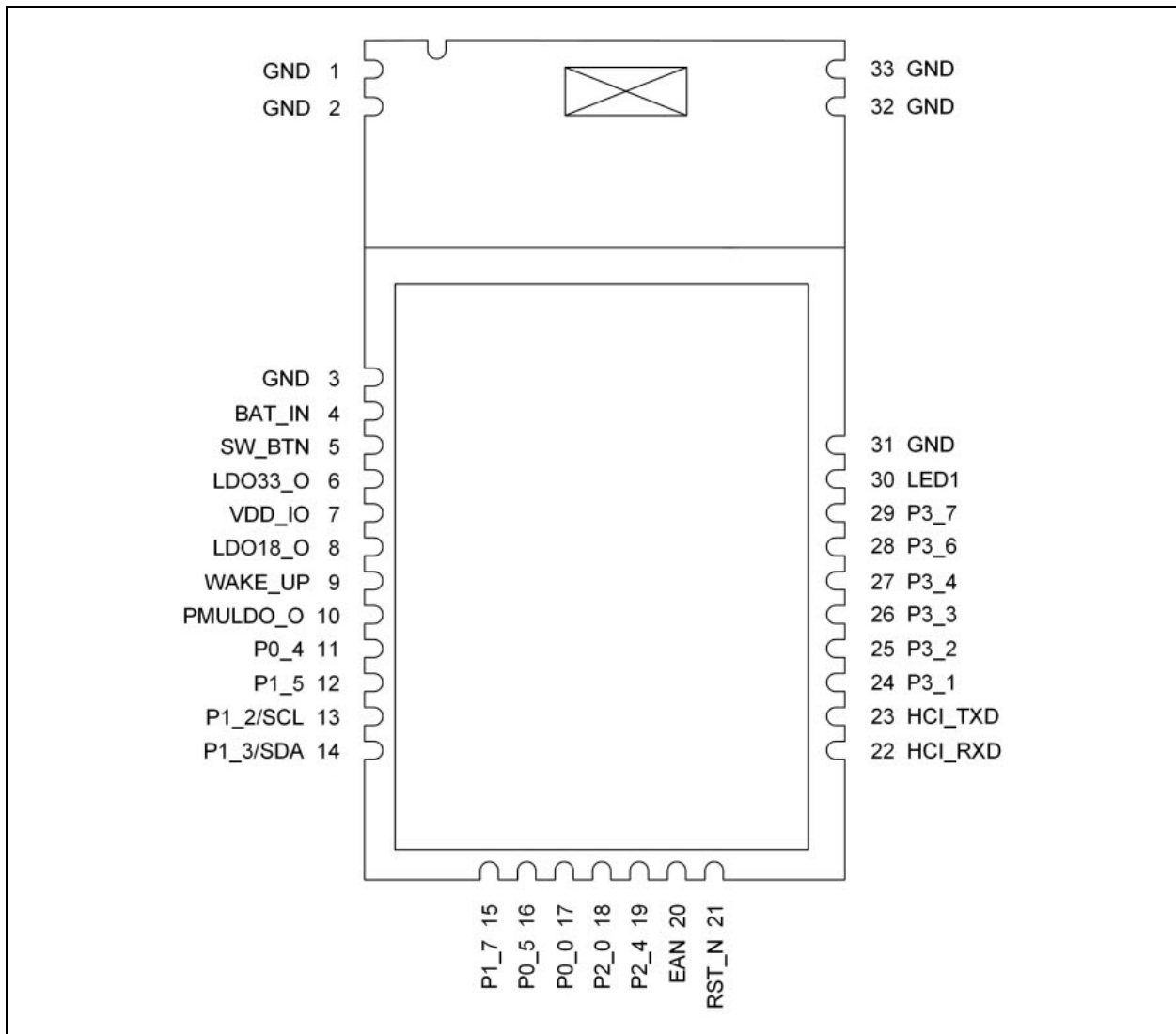

**FIGURE 1-3: BM78SPP05MC2/NC2 PIN DIAGRAM**

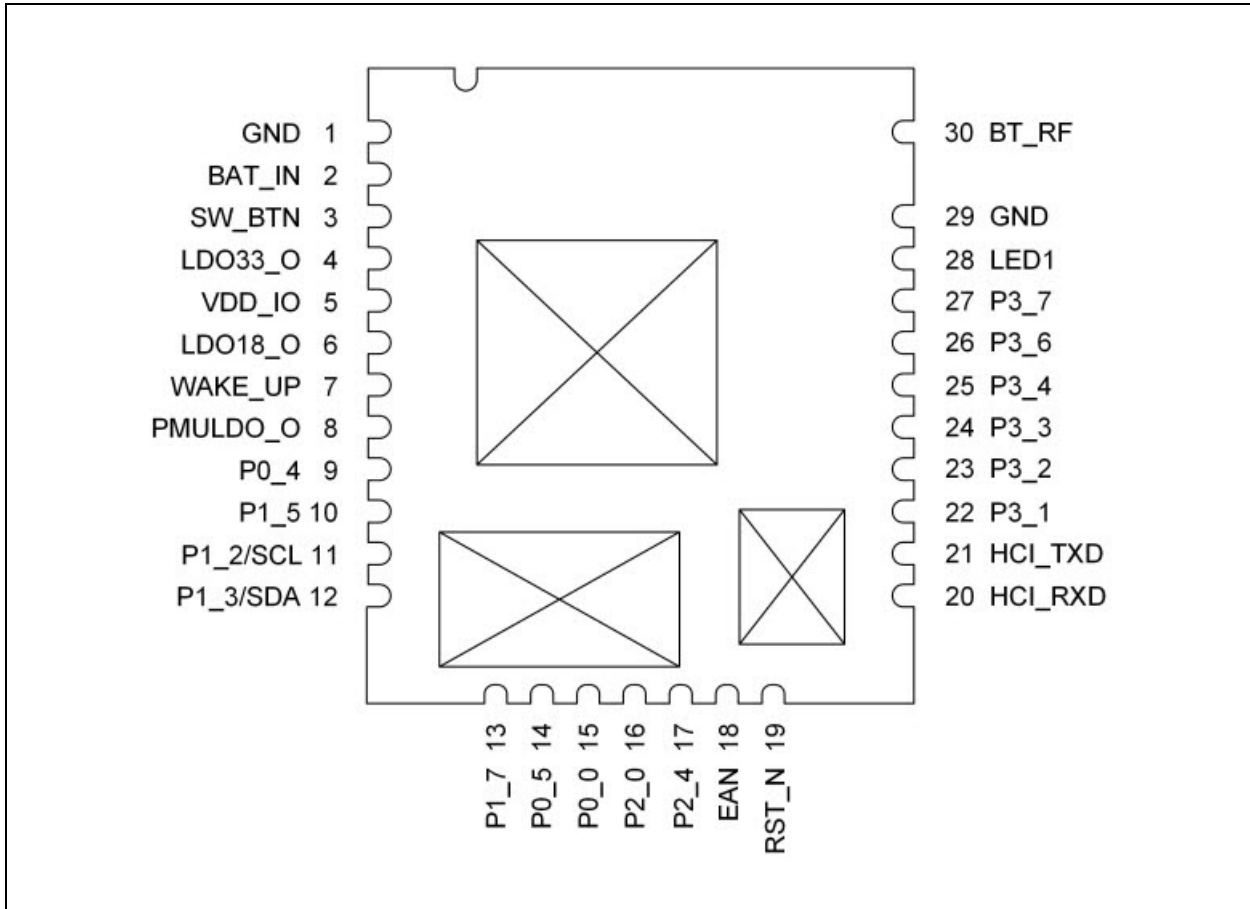

## 2.0 APPLICATION INFORMATION

### 2.1 System Configuration

The system configuration I/O pins, P2\_0, P2\_4 and EAN, are used to set the Configuration and Firmware Programming modes.

Each of these pins has internal pull-up and allows configuration settings and firmware update from the UART. The following table provides the system configuration settings.

**TABLE 2-1: SYSTEM CONFIGURATION SETTINGS**

Module	P2_0	P2_4	EAN	Operational Mode
BM78SPPX5NC2 (ROM Variant)	Low	High	High	Test mode (Write EEPROM)
	High	High	High	APP mode (Normal operation)
BM78SPPX5MC2 (Flash Variant)	Low	Low	High	Write Flash
	Low	High	Low	Test mode (Write EEPROM)
	High	High	Low	APP mode (Normal operation)

### 2.2 Control and Indication I/O Pins

The I/O pins, P0\_0, P0\_5, P1\_7, P3\_1, P3\_2, P3\_3, P3\_4 and P3\_7 are configurable control and indication pins. The control signals are input to the BM78 module and the indication signals are output from the BM78 module. The following table provides default I/O pin configuration details.

**TABLE 2-2: CONTROL AND INDICATION I/O PIN ASSIGNMENTS**

PIN Symbol	Default Configuration
P0_0	UART_RTS <sup>(1,2)</sup>
P0_5	N/C
P1_7	UART_CTS <sup>(1,2)</sup>
P3_1	INQUIRY CONTROL
P3_2	LINK_DROP_CONTROL (DISCONNECT)
P3_3	UART_RX_IND
P3_4	PAIRING_KEY
P3_7	LOW_BATTERY_IND

**Note 1:** The RTS pin can only be assigned to P0\_0 and the CTS pin can only be assigned to P1\_7.

**2:** The RTS and CTS pins can be configured as GPIOs if flow control is disabled.

The following table provides the configurable functions and descriptions of I/O pins.

**TABLE 2-3: CONFIGURABLE FUNCTIONS AND DESCRIPTIONS**

Function Name	Description
Low Battery Indication	This function, when assigned to a pin, ensures the output goes low when the battery level is below a specified level. The UI tool can set the battery level.
RSSI Indication	When assigned to a pin, this function can be used to indicate the quality of the link based on the Received Signal Strength Indicator (RSSI) level. If the RSSI level is lower than the specified values, then the RSSI indication pin goes low.
Link Drop Control	When assigned to a pin, this function can be used to force the module to drop the current Bluetooth <sup>®</sup> Low Energy (BLE) link with a peer device. Pulling the Link Drop pin low will force the disconnect. The pin needs to be pulled low for at least 10 ms.
UART RX Indication	When assigned to a pin, this function enables communication with the UART when the module is in Low-Power mode. When not in Low-Power mode, the module runs on a 16 MHz clock. If the user intends to provide data or commands through UART in the Low-Power mode, then the UART_RX_IND pin needs to be pulled low and the user has to wait at least 5 ms before sending the data. Pulling the UART_RX_IND pin low allows the module to operate the 16 MHz clock and to enable UART.
Pairing Key	When assigned to a pin, this function can be used to force the module to enter Standby mode. The pin needs to be pulled down for at least 160 ms.
Inquiry Control	When assigned to a pin, this function forces the module to enter Inquiry mode (Bluetooth Classic). The pin must be pulled low for at least 240 ms for the device to enter Inquiry mode.
Profile_IND	When assigned to a pin, this function can be used to indicate whether the current connection is in Basic Data Rate (BDR)/Enhanced Data Rate (EDR) (Bluetooth Classic) or in BLE. If the Profile_IND pin is high, then the current connection is the BDR/EDR connection. If low, then the current connection is a BLE connection. This pin is valid only for Link state.

## 2.3 Status Indication I/O Pins

The I/O pins, P1\_5 and P0\_4, are status indicator pins: STATUS\_IND\_1 and STATUS\_IND\_2. Both the pins provide status indication to host MCUs. The following table provides status indication of the P1\_5 and P0\_4 pins.

**TABLE 2-4: STATUS INDICATION**

P1_5/STATUS_IND_1	P0_4/STATUS_IND_2	Indication
H	H	Power-on (default setting) and Deep Sleep state. HH status should be stable for at least 500 ms.
H	L	Access state.
L	H	Link state (UART data transmitting).
L	L	Link state (no UART data transmitted).

**Legend:** L = Low H = High

## 2.4 Power Tree

The following figure illustrates the power tree diagram of the BM78 module.

**FIGURE 2-1: POWER TREE DIAGRAM**

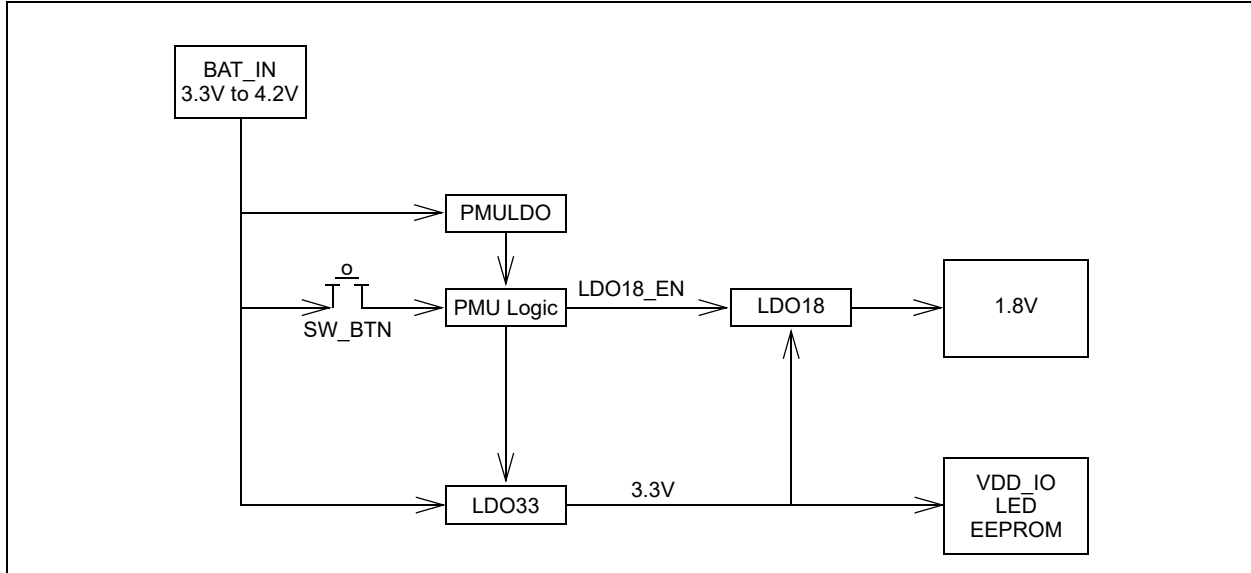

## 2.5 Software Power Button (SW\_BTN)

The Software power button (SW\_BTN) input pin powers the BM78 module on (high) or off (low) into the S4 mode. The S4 mode is the Deep Sleep mode and the S2 mode is the Sleep mode. The S4 mode can only be triggered by the SW\_BTN pin and the power consumption is lower in the S4 mode.

The following figures illustrate the waveforms of the BM78 module in the high and low status, that is access and link status.

**FIGURE 2-2: SW\_BTN TIMING (HIGH) AT APPLICATION MODE**

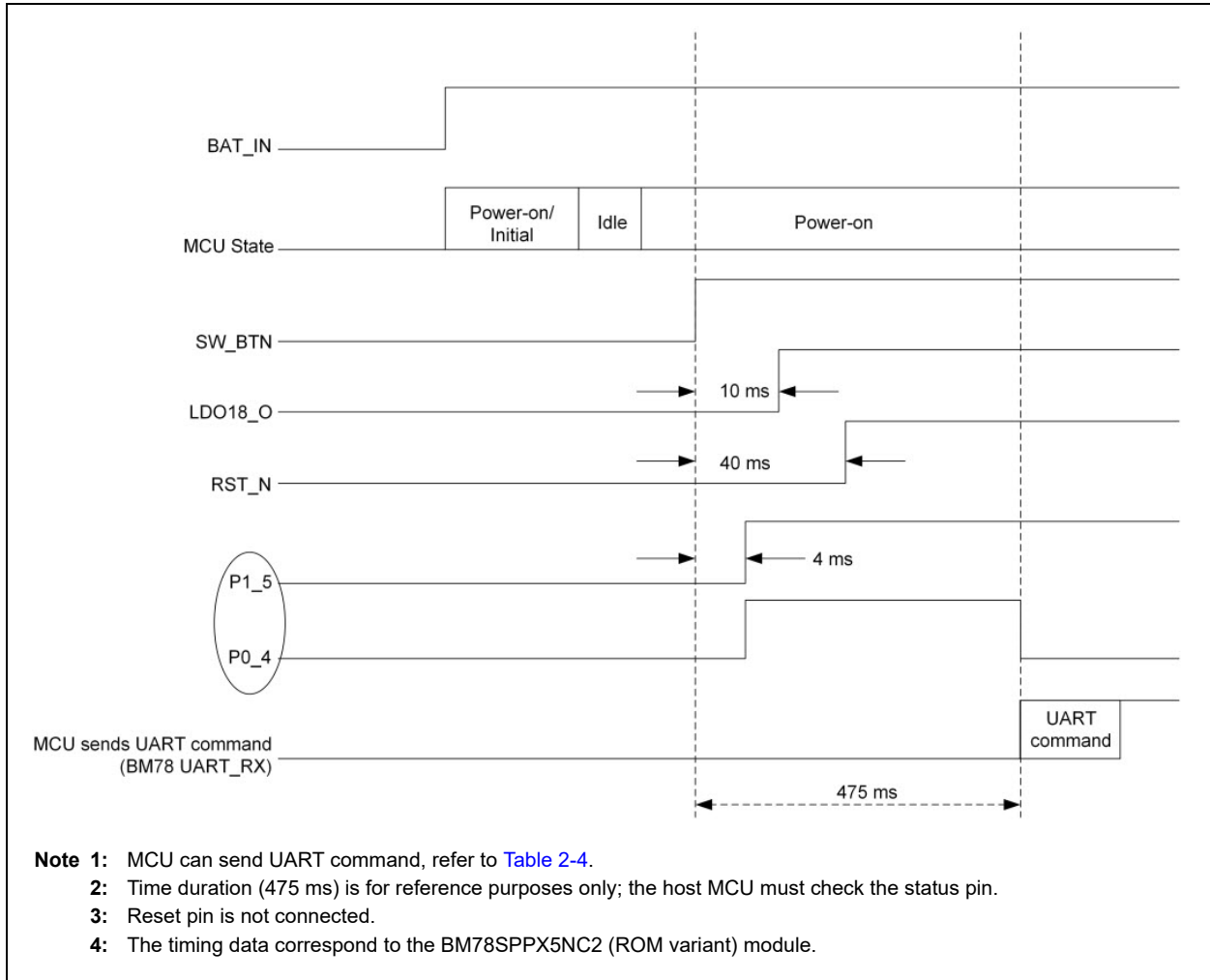

**FIGURE 2-3: SW\_BTN TIMING AT ACCESS STATES**

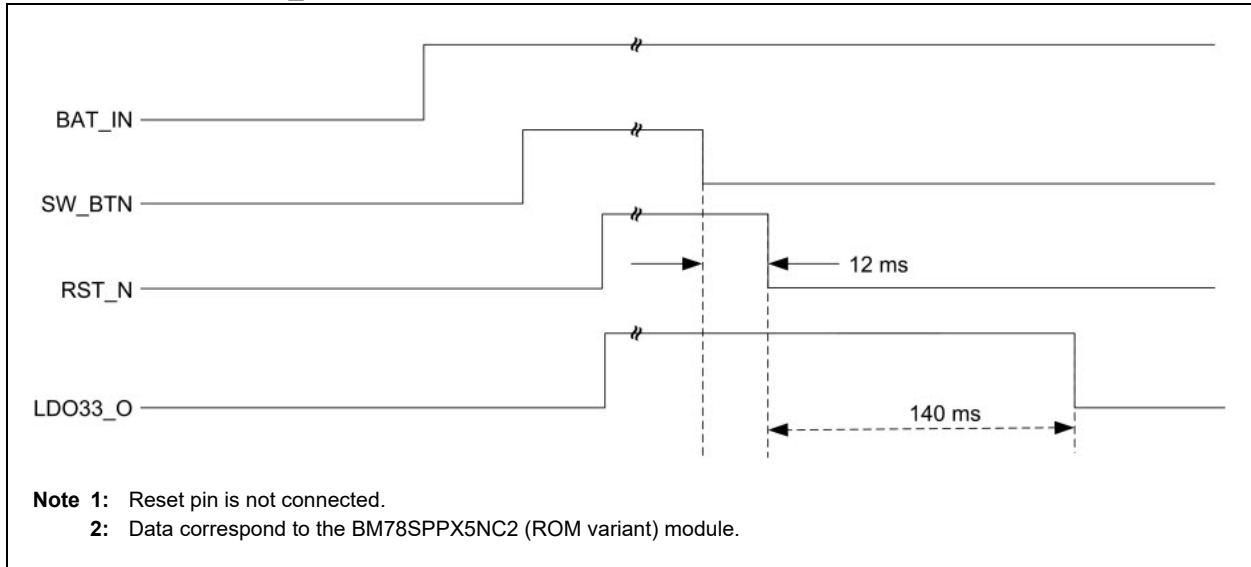

**FIGURE 2-4: SW\_BTN TIMING (LOW) AT LINK STATES**

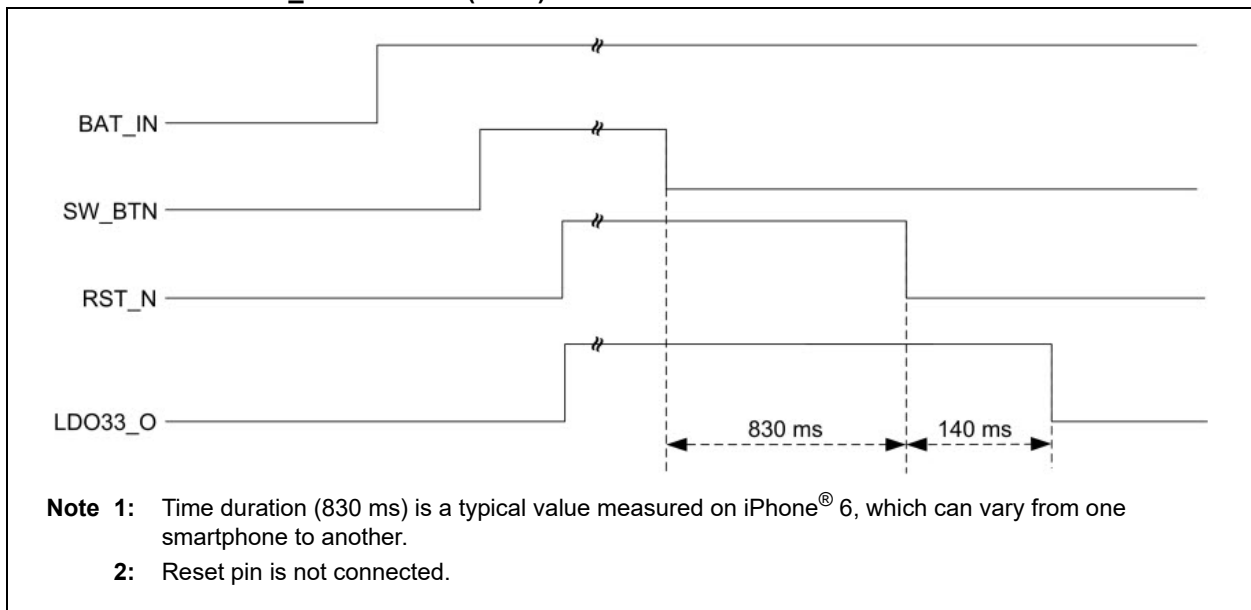

## 2.6 WAKE-UP

The WAKE\_UP input pin wakes the BM78 module from Sleep mode. The WAKE\_UP pin is active-low and places the module from Sleep mode (S2) to Standby mode. The following figure illustrates the timing diagram of the BM78 module in the Wake-up mode.

**FIGURE 2-5: WAKE-UP TIME**

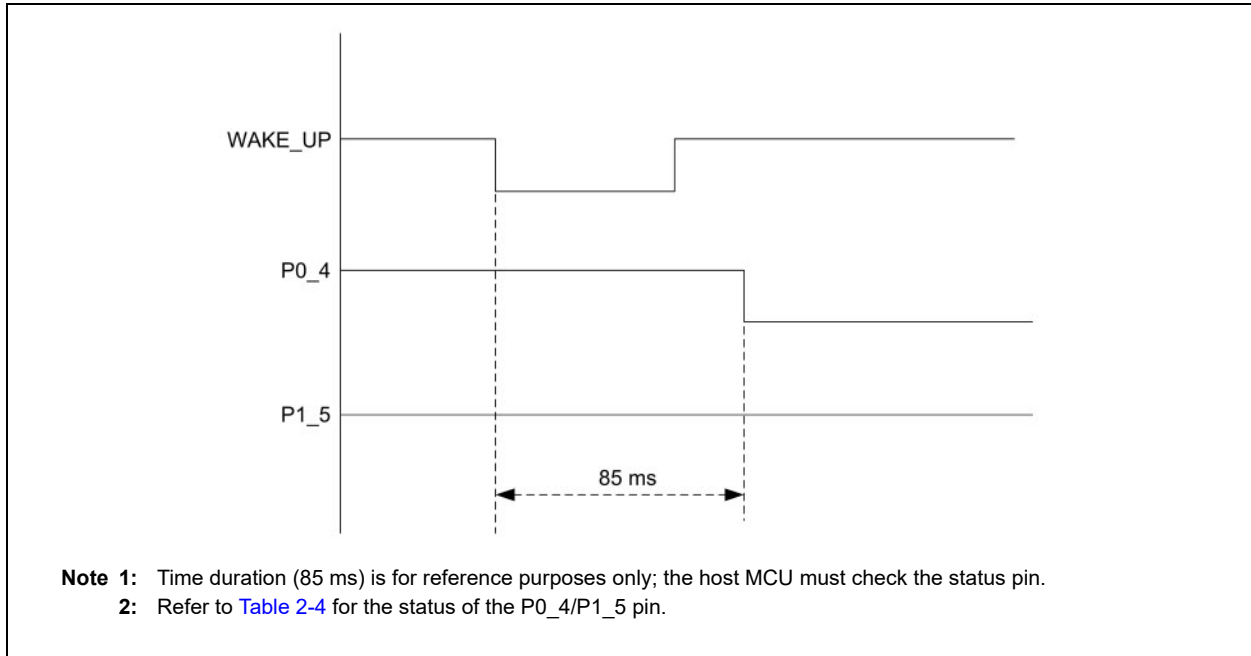

## 2.7 External Reset

The BM78 module provides a Watchdog Timer (WDT) to reset the chip. It has an integrated Power-on Reset (POR) circuit that resets all circuits to a known Power-on state. This action can also be driven by an external Reset signal, which is used to externally con-

trol the device by forcing it into a POR state. The RST\_N signal input is active-low and connection is not required in most of the applications.

The following figure illustrates the timing diagram of the BM78 module when it is in the Reset (RST\_N is set to active-low) state.

**FIGURE 2-6: TIMING WAVEFORMS ON RESET**

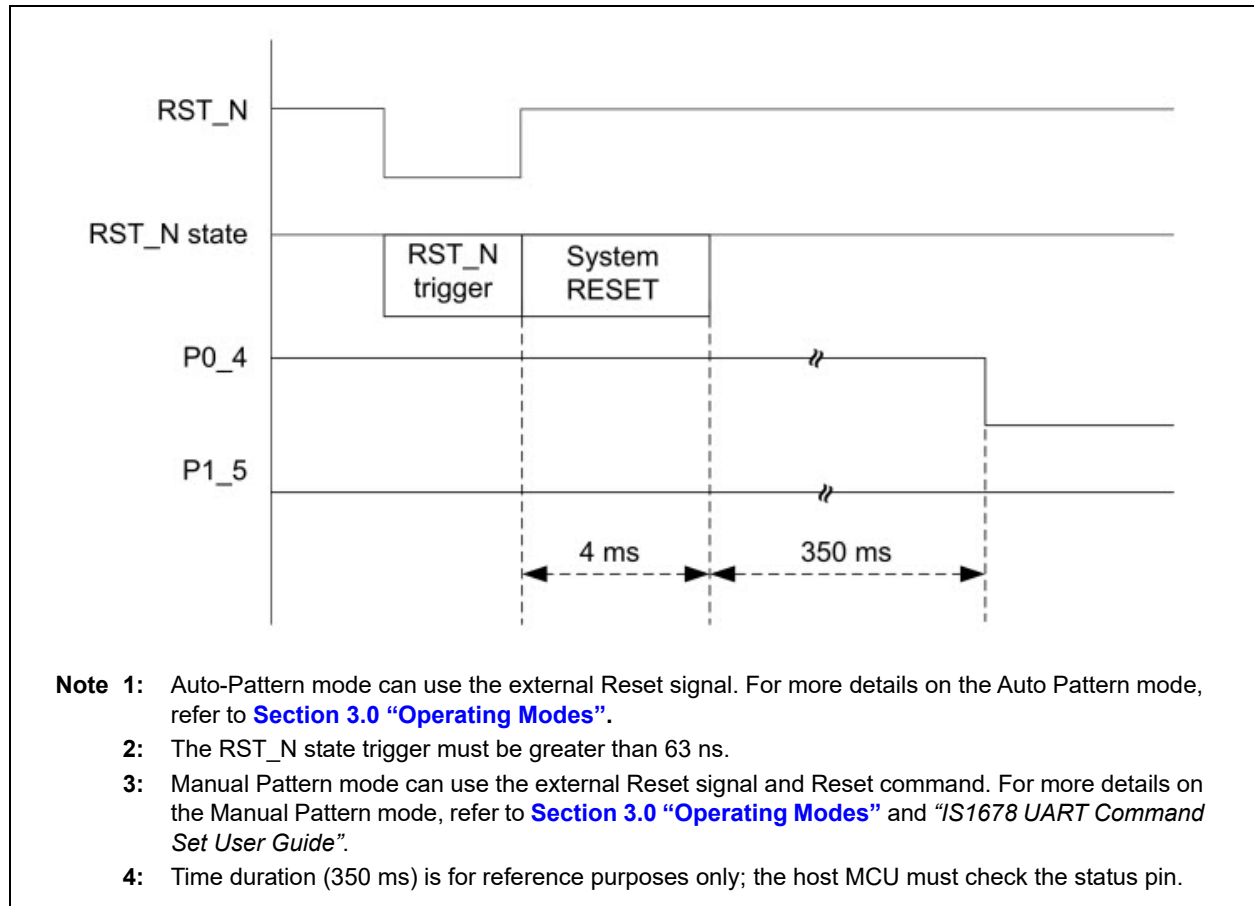

## 2.8 LED Driver

The BM78 module has a dedicated LED driver and the LED (LED1) can be connected directly with the BM78 module using this driver; see The following figure.

The maximum current sourcing for the LED is 5 mA and it provides 16 options (steps) to trim the brightness. The LED brightness can be configured using the UI tool, a Windows-based utility.

The following are status indications of the LED. Each indication is a configurable flashing sequence:

- Standby
- Link Back
- Low Battery
- Inquiry
- Link

**FIGURE 2-7: LED DRIVER**

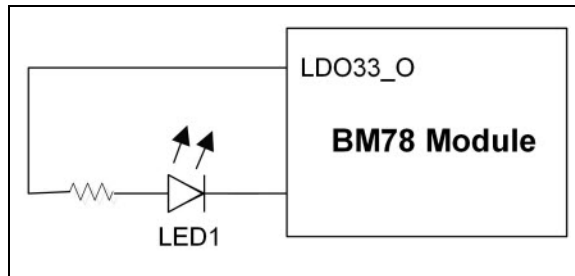

## 2.9 Host MCU Interface Over UART

The following figure illustrates the UART interface with the host MCU and power scheme using 3.3V to the VDD. Battery power is applied to the BAT\_IN pin. From the LDO33\_O pin, voltage can be routed to the

VDD\_IO pin and external circuitry, including the MCU. This power scheme ensures that the BM78 module and MCU I/O voltages are compatible.

**Note:** The internal 3.3V LDO current source must not exceed the maximum value of 50 mA.

**FIGURE 2-8: POWER AND MCU INTERFACE EXAMPLE FOR BM78 MODULE**

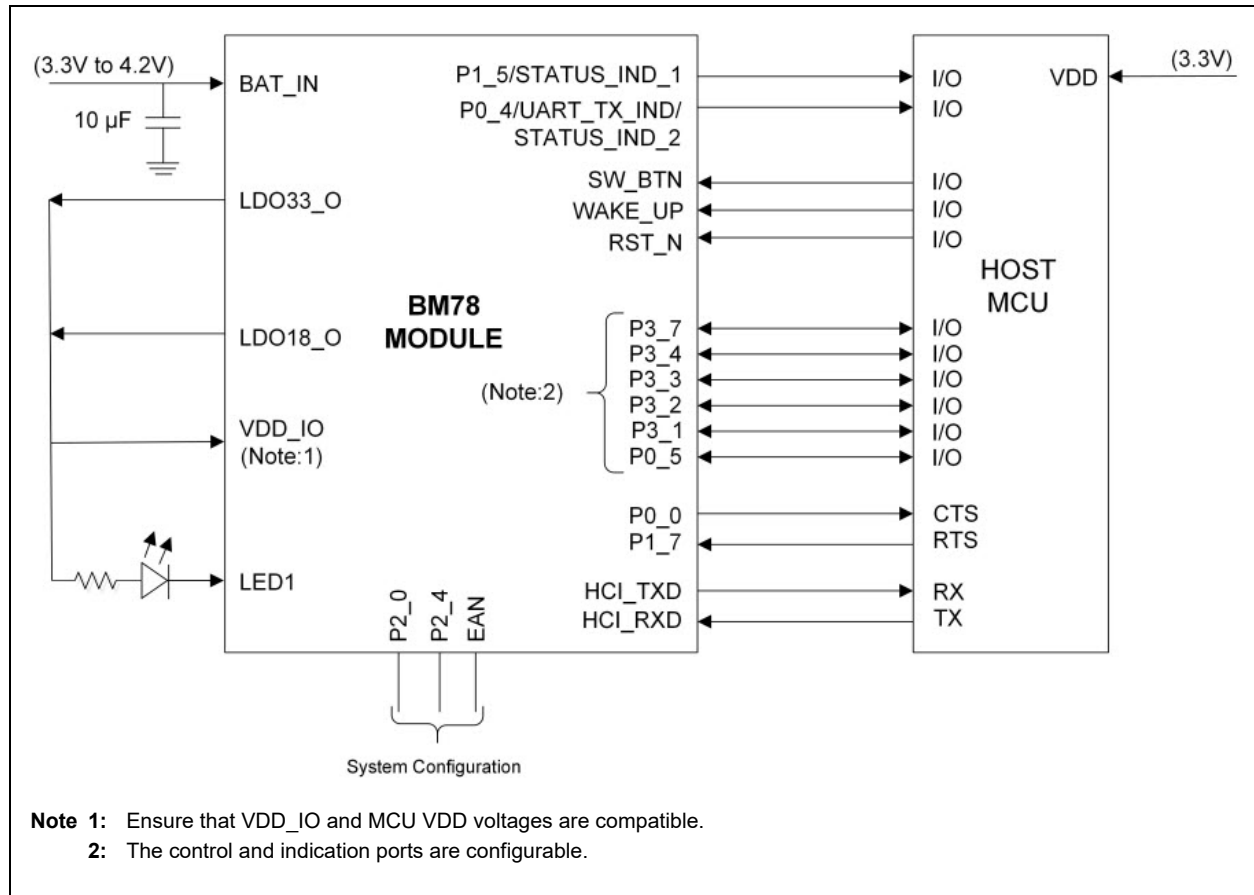

## 2.10 Reference Circuit

The following figures illustrate the reference schematic of the power supply design implemented for the BM78 module.

**FIGURE 2-9: BM78SPP05MC2/NC2 REFERENCE CIRCUIT**

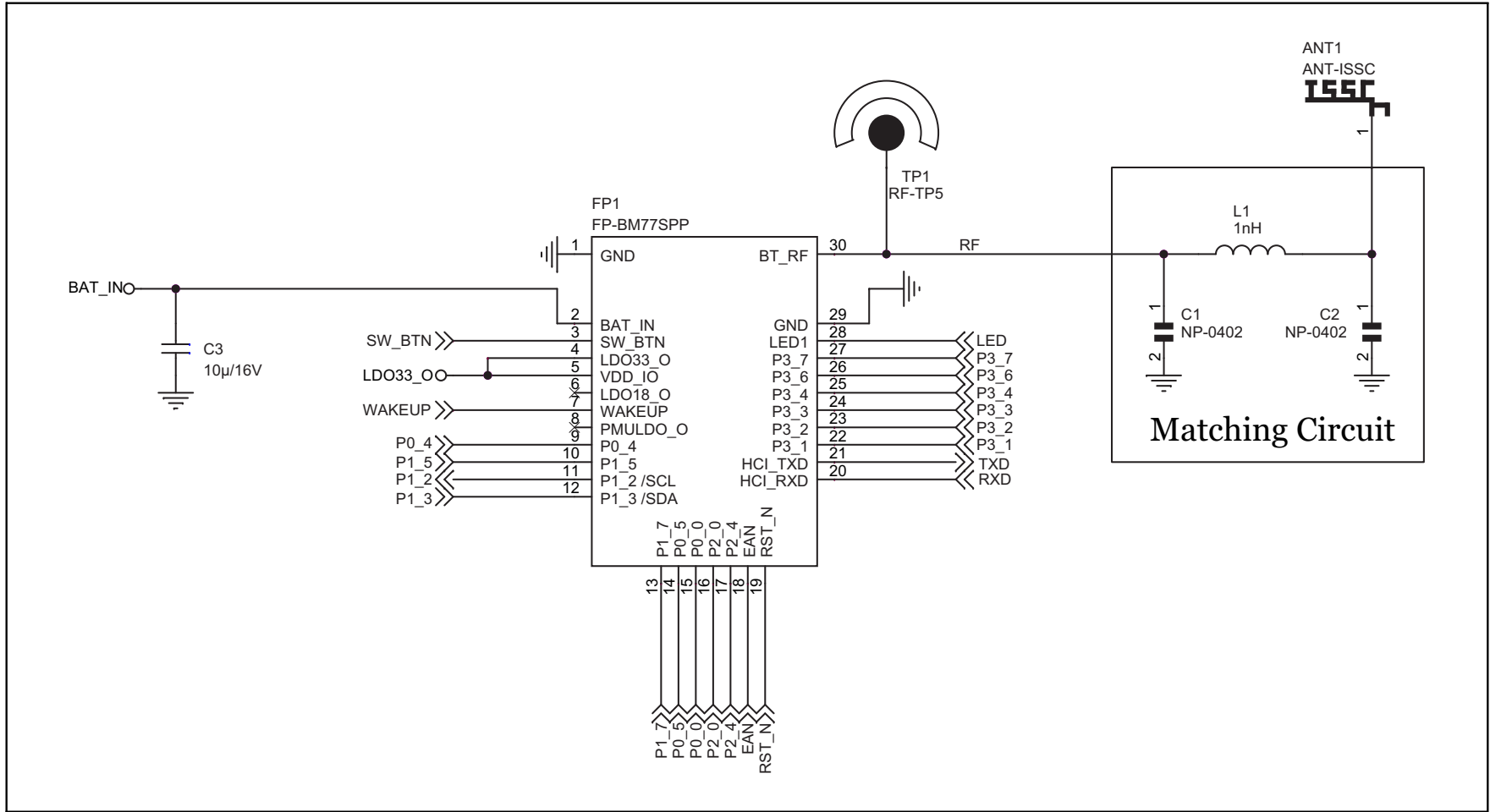

**FIGURE 2-10: BM78SPP05MC2/NC2 REFERENCE CIRCUIT**

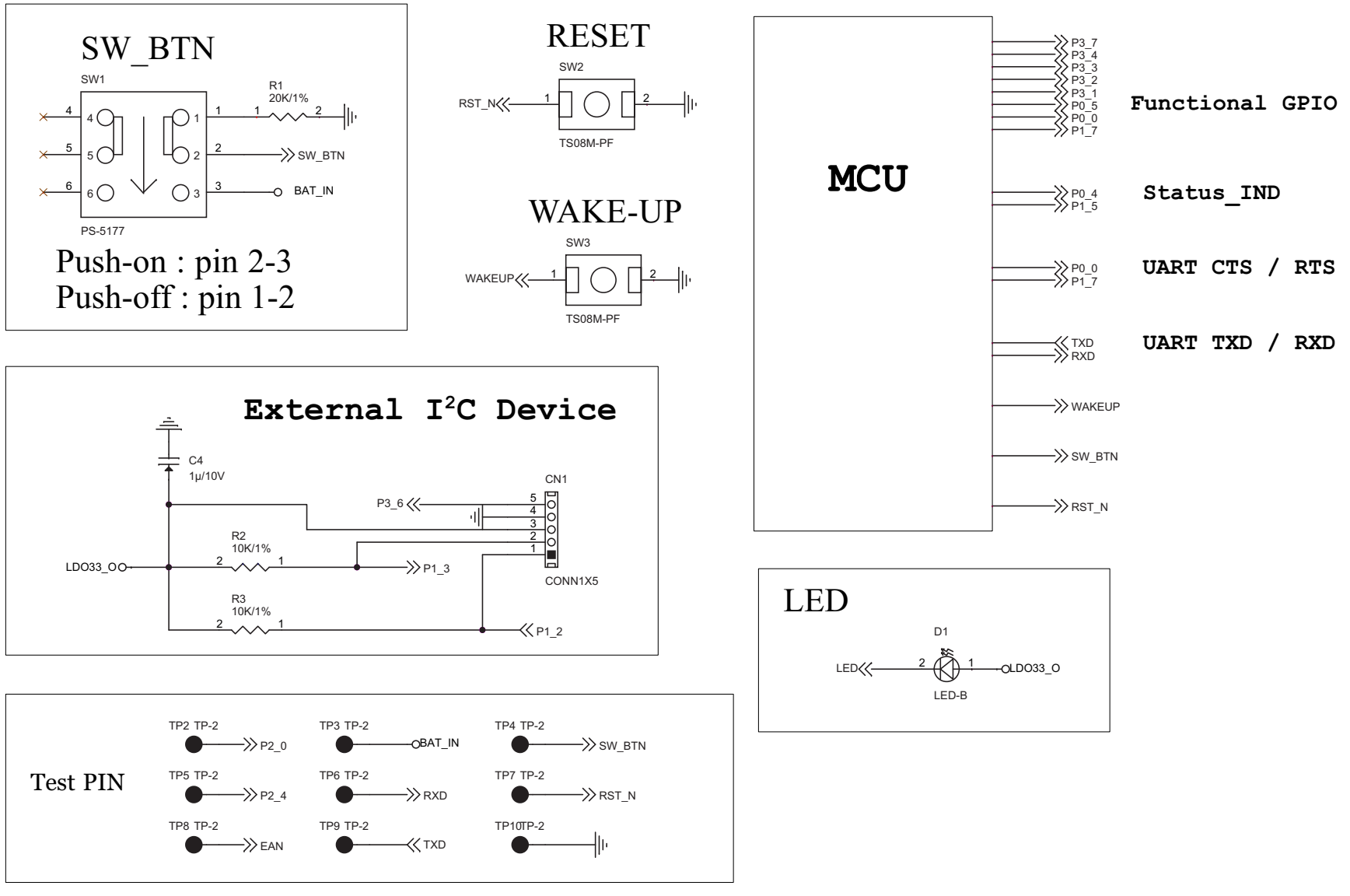

**FIGURE 2-11: BM78SPPS5MC2/NC2 REFERENCE CIRCUIT**

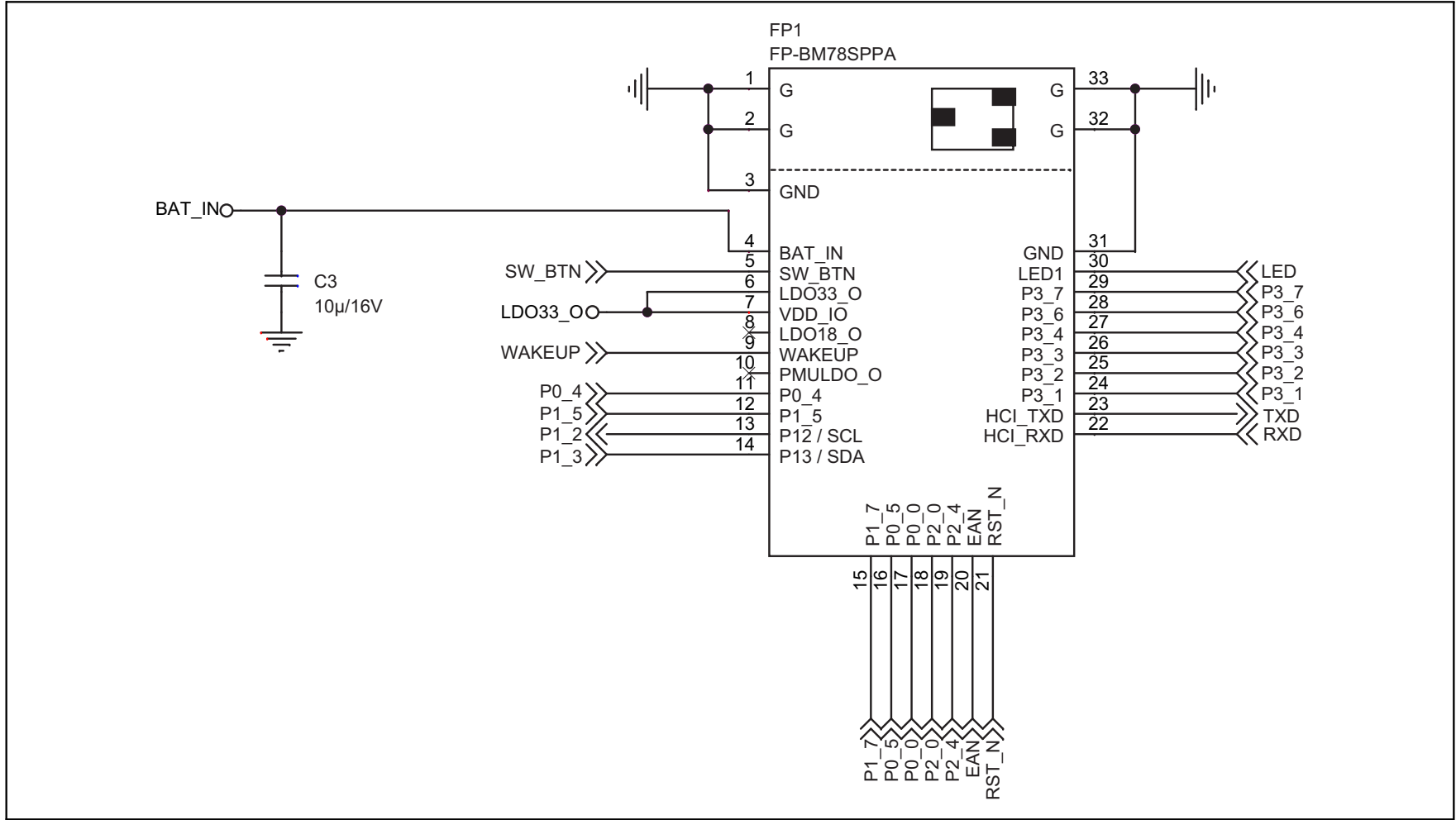

**FIGURE 2-12: BM78SPPS5MC2/NC2 REFERENCE CIRCUIT**

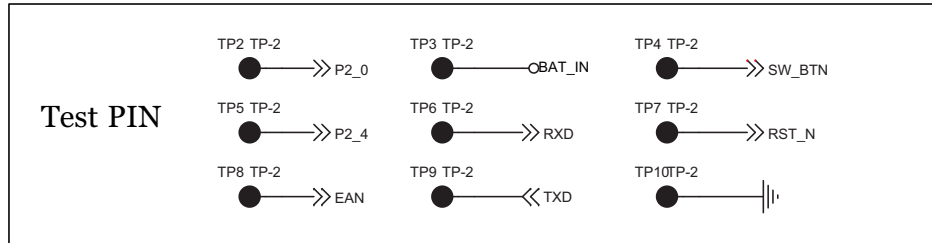
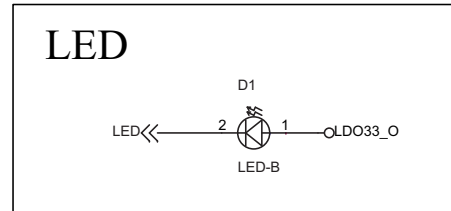
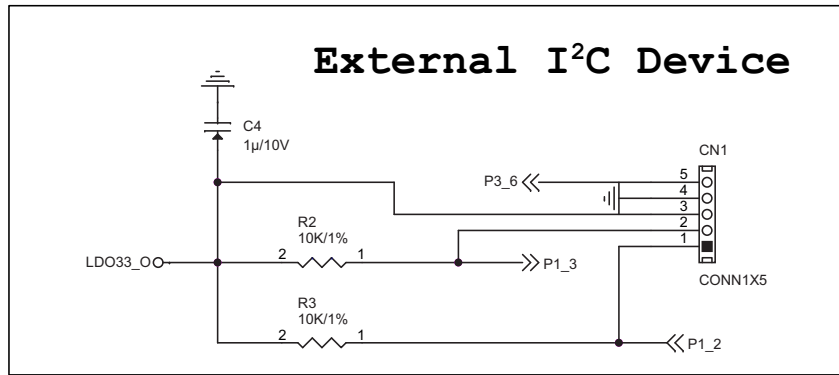
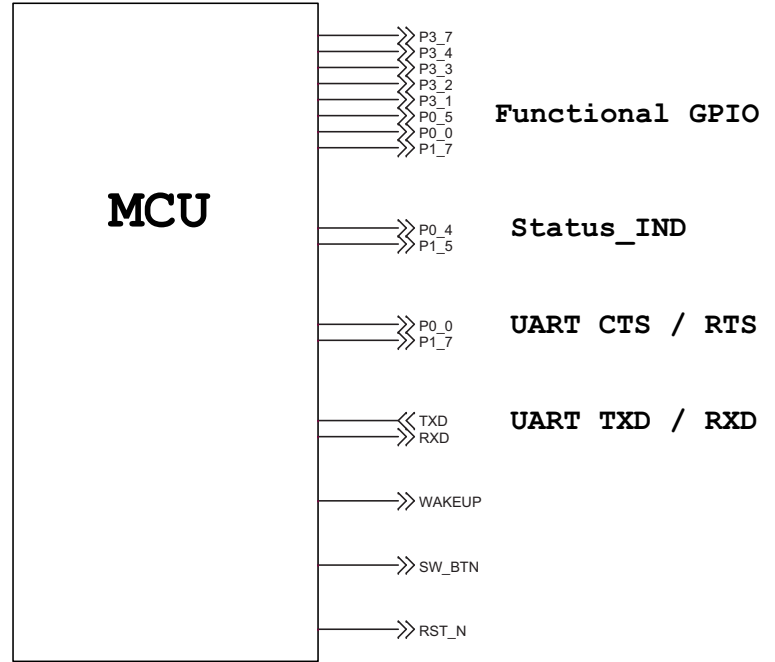
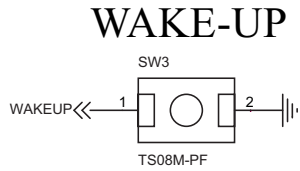
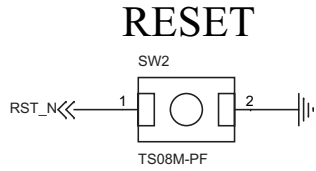
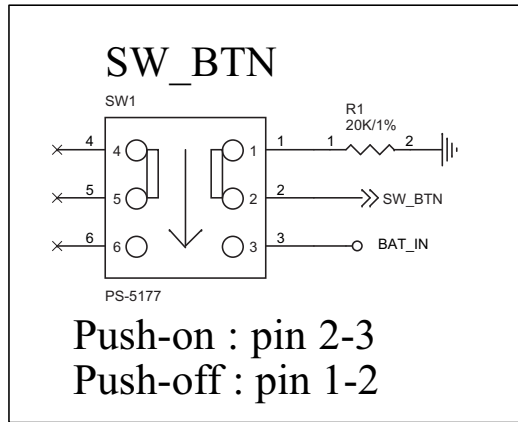

## 3.0 OPERATING MODES

The BM78 module allows the user to operate the module in two distinct modes:

- Auto-Pattern mode
- Manual Pattern mode

The Auto-Pattern mode and the Manual Pattern mode use different state machines. The BM78 module can be operated in either of these modes by setting the value in the EEPROM memory location. The BM78 module is in Auto-Pattern mode by default. To modify the EEPROM values, the module must be placed in the “Write EEPROM and Test mode” through the pins, P2\_0, P2\_4 and EAN.

The UI tool provides an easy Windows Graphical User Interface (GUI) to set or modify the EEPROM settings on the BM78 module.

**Note:** The UI tool is available for download from the Microchip website at: [www.microchip.com/BM78](http://www.microchip.com/BM78).

The following figure illustrates the basic algorithm, followed by the BM78 module during start-up, in deciding which state machine to be used for operation.

**FIGURE 3-1: OPERATING MODE CONFIGURATION**

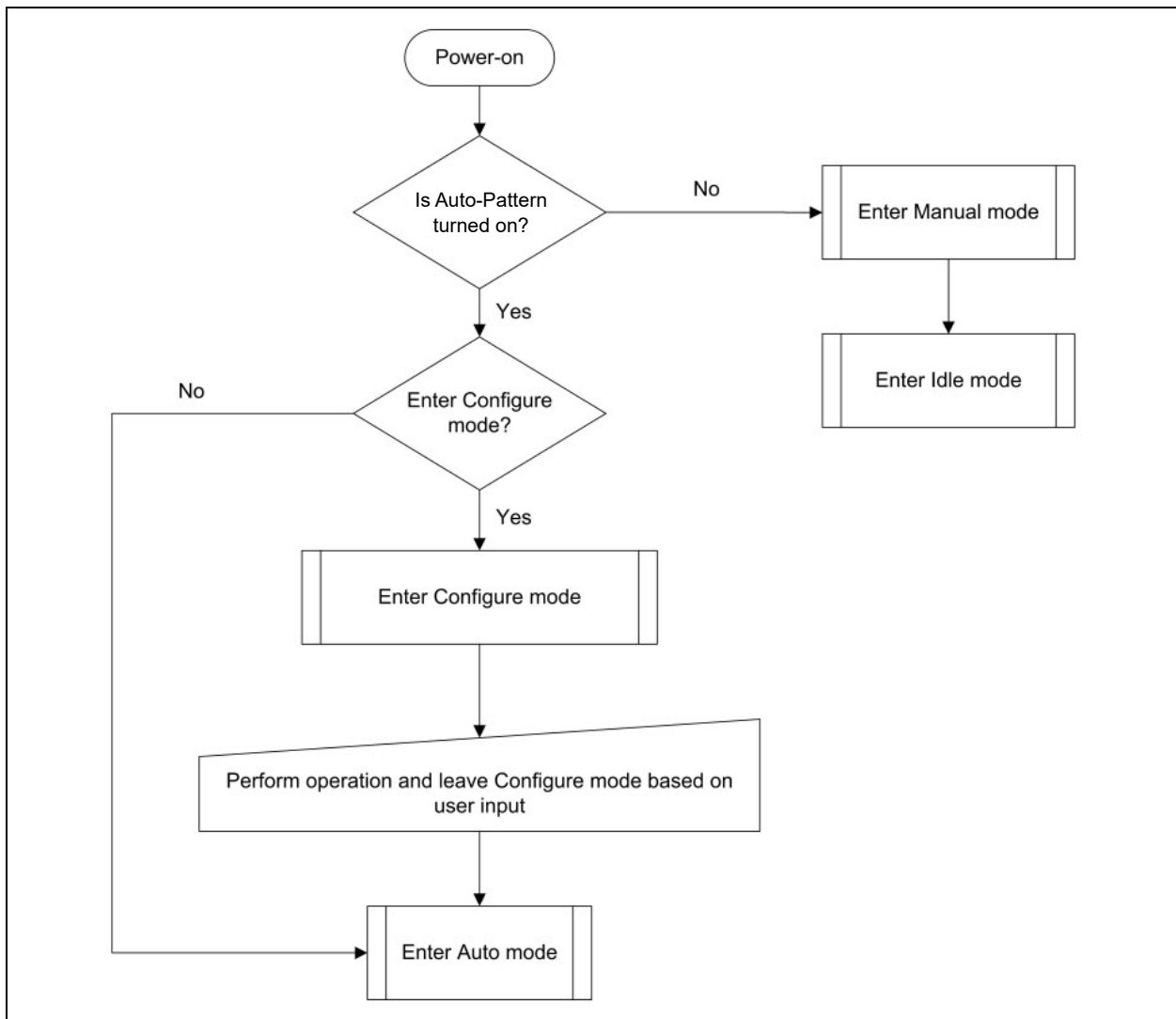

## 3.1 Auto-Pattern Mode

The Auto-Pattern mode is a state machine in which the Bluetooth related operations are automated. It is primarily used to connect the module to a peer device and create a data pipe with the peer device through the Transparent UART mode, thus providing a “cable replacement” solution. Also, the BM78 module allows

the user to enter some configuration commands in the Auto-Pattern mode. For more details on the list of configuration commands that can be used in Auto-Pattern mode, refer to the “*IS1678 UART Command Set User Guide*”.

The following figure illustrates the basic state machine in the Auto-Pattern mode.

**FIGURE 3-2: AUTO-PATTERN MODE**

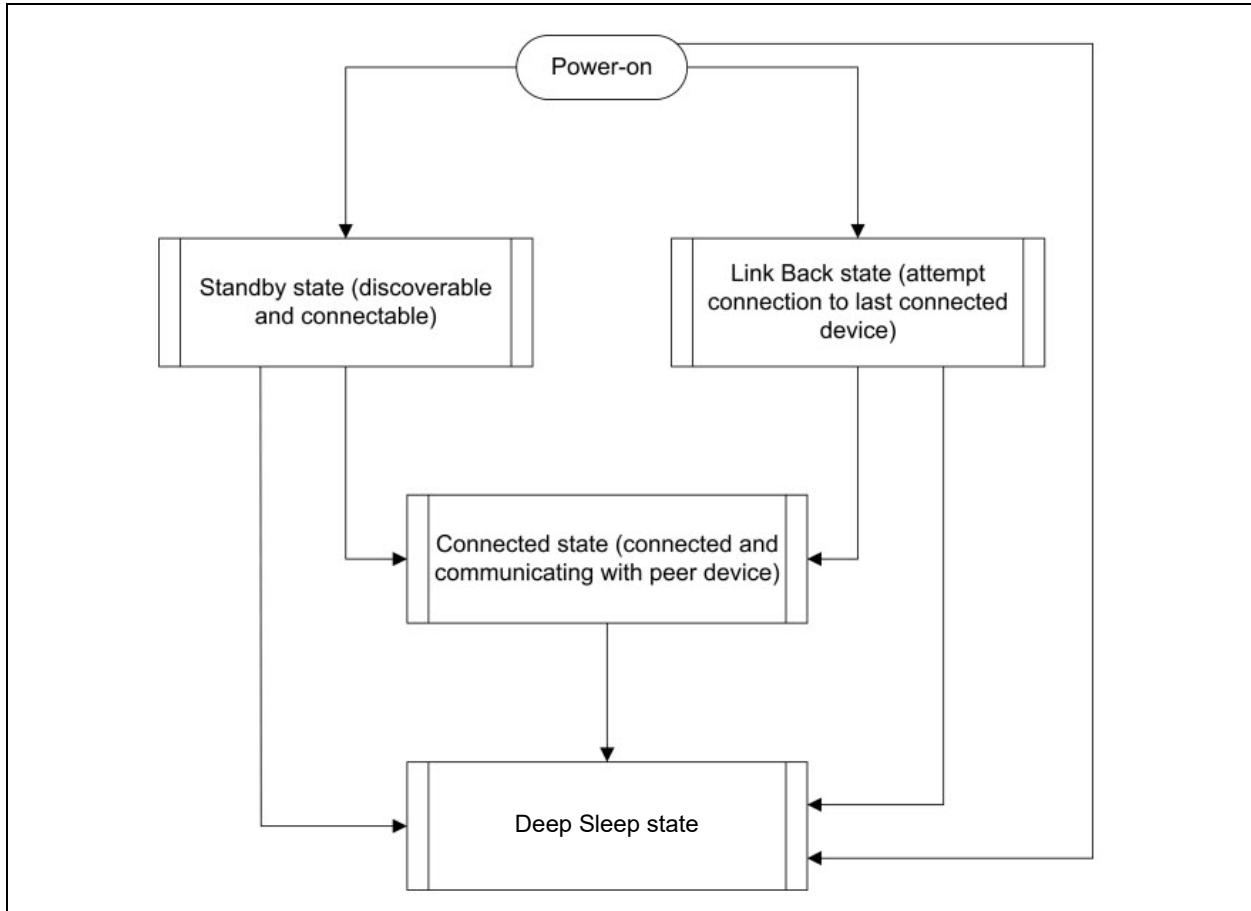

To evaluate and test the BM78 module in Auto-Pattern mode, download and install the Auto-Pattern tool (Windows-based GUI emulation tool), which is available on the Microchip website. This tool implements the communication protocol for Auto-Pattern mode. It also provides a fast and easy way to test the functions and options available in the Auto-Pattern mode.

**Note:** The Auto-Pattern tool and “*IS1678 UART Command Set User Guide*” are available for download from the Microchip website at: [www.microchip.com/BM78](http://www.microchip.com/BM78).

## 3.2 Manual Pattern

The Manual Pattern mode provides full control of the BM78 module to the user and the module operates only based on the commands from the user or host MCU.

The following figure illustrates the state machine followed by the BM78 module in the Manual Pattern mode.

**FIGURE 3-3: STATE CHANGES BY MCU IN MANUAL PATTERN**

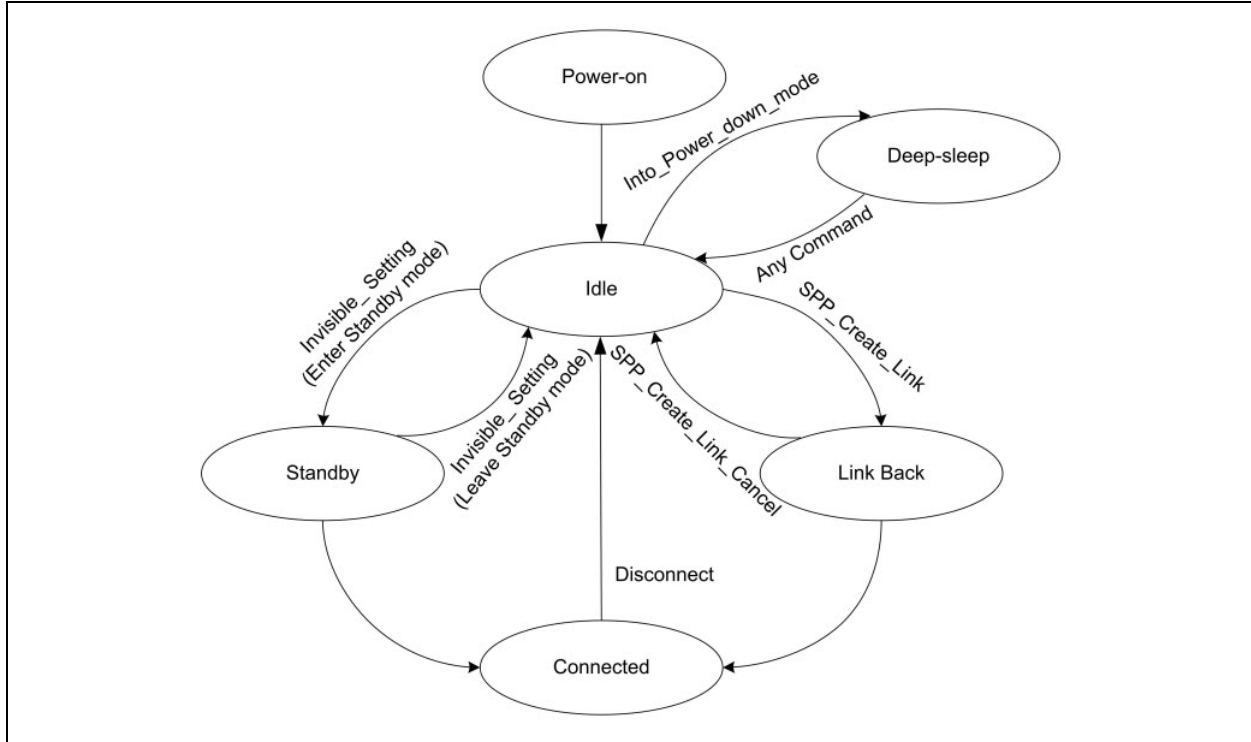

The Manual Pattern mode also allows the Transparent UART mode. There is a small difference in the protocols followed in the Manual Pattern mode and the Auto-Pattern mode. For more details on the protocol differences, refer to the “*IS1678 UART Command Set User Guide*”.

To evaluate and test the BM78 module in Manual Pattern mode, download and install the Manual Pattern tool (Windows-based GUI emulation tool), which is available from the Microchip website. This tool implements the

communication protocol for Manual Pattern mode. It also provides a fast and easy way to test the functions and options available in the Manual Pattern mode.

**Note:** The Manual Pattern tool and “*IS1678 UART Command Set User Guide*” are available for download from the Microchip website at: [www.microchip.com/BM78](http://www.microchip.com/BM78).

---

---

## 4.0 ELECTRICAL CHARACTERISTICS

This section provides an overview of the electrical characteristics of the BM78 module. Additional information will be provided in future revisions of this document as it becomes available.

Absolute maximum ratings for the BM78 module are listed below. Exposure to these maximum rating conditions for extended periods may affect device reliability. Functional operation of the device at these or any other conditions, above the parameters indicated in the operation listings of this specification, is not implied.

### Absolute Maximum Ratings

Ambient temperature under bias .....	-20°C to +70°C
Storage temperature .....	-40°C to +125°C
Voltage on VDD with respect to VSS .....	-0.3V to +3.6V
Maximum output current sink by any I/O pin.....	12 mA
Maximum output current sourced by any I/O pin.....	12 mA

<p><b>Note:</b> Stresses listed under “<b>Absolute Maximum Ratings</b>” may cause permanent damage to the device. This is a stress rating only. The functional operation of the device at those or any other conditions, and those indicated in the operation listings of this specification, is not implied. Exposure to maximum rating conditions for extended periods may affect device reliability.</p>
---

The following tables provide the recommended operating conditions and the electrical specifications of the BM78 module.

**TABLE 4-1: RECOMMENDED OPERATING CONDITIONS**

Rating		Min.	Typical	Max.
Ambient Operating Temperature Range		-20°C	+25°C	+70°C
Relative Humidity (Operating)		10%	—	90%
Relative Humidity (Storage)		10%	—	90%
ESD	HBM	—	±2 KV	—
	MM	—	±200V	—
HTOL (Note 1)		—	1000 hrs	—
Supply Voltage: BAT_IN		3.3V	—	4.2V
Supply Voltage: 1V8, VCC_RF, VDD_XO, AVDD_SAR		1.8V	1.9V	2.1V
SW_BTN		3.3V	—	4.2V
LED1		—	—	3.6V
Reset $V_{THRES}$ Threshold Voltage		—	1.6V	—
$V_{IL}$ Input Logic Levels Low		-0.3V	—	0.8V
$V_{IH}$ Input Logic Levels High		2.0V	—	3.6V
$V_{OL}$ Output Logic Levels Low ( $I_{OL} = 12$ mA)		—	—	0.4V
$V_{OH}$ Output Logic Levels High ( $I_{OH} = 12$ mA)		2.4V	—	—
RF Continuous Tx Mode		—	—	43 mA
RF Continuous Rx Mode		—	—	37 mA

**Note 1:** HTOL life test condition: +125°C, BAT\_IN = 4.2V, LDO33\_O = 3.3V, LDO18\_O = 1.9V.

**TABLE 4-2: 3.3V LDO ELECTRICAL PARAMETERS<sup>(1,2)</sup>**

Parameter	Min.	Typical	Max.	Unit
Operating Temperature	-20	—	+70	°C
Output Current ( $V_{IN} = 3.6$ V/load regulation with 100 mV drop)	—	100	—	mA
Quiescent Current ( $V_{IN} = 3.6$ V)	—	150	—	µA

**Note 1:** With 10 µF capacitor at LDO33\_O as the condition for IP verification.

**2:** Output voltage can be calibrated using the MP tool.

**TABLE 4-3: PMU LDO<sup>(1,2)</sup>**

Parameter	Min.	Typical	Max.	Unit
Operating Temperature	-20	—	+70	°C
Output Current ( $V_{IN} = 3.6$ V/load regulation with 0.3 mV drop)	—	100	—	µA
Quiescent Current ( $V_{IN} = 3.6$ V)	—	120	—	µA

**Note 1:** With 1 µF capacitor at PMULDO\_O as the condition for IP verification.

**2:** Output voltage can be calibrated by using the MP tool.

**TABLE 4-4: SAR-ADC AND BATTERY VOLTAGE DETECTOR**

Parameter	Min.	Typical	Max.	Unit
Operating Temperature	-20	—	+70	°C
AVDD_SAR Power Supply	—	1.8	—	V
SAR_BAT Detection ( <b>Note 1</b> )	3.3	—	4.2	V
Resolution	—	10	—	bit
Operating Current (including band gap)	—	—	1	mA
Deep Sleep Current	—	—	1	µA

**Note 1:** SAR\_BAT is connected with BAT\_IN internally for battery voltage detection.

**TABLE 4-5: INTENSITY CONTROLLABLE LED DRIVER**

Parameter	Min.	Typical	Max.	Unit
Operating Temperature	-20	—	+70	°C
Open-Drain Voltage	—	—	3.6	V
Current Step	—	0.3	—	mA
Programmable Current Range	0	—	5	mA
Intensity Control	—	16	—	step
Power-Down Open-Drain Current	—	—	1	µA
Deep Sleep Current	—	—	1	µA

**TABLE 4-6: POWER CONSUMPTION – CLASSIC<sup>(1,2)</sup>**

Test Condition	Current Consumption (avg.) (mA)	Remarks
Standby Mode	2.543	—
Deep Sleep Mode	0.187	—
Connected+Sniff, Central (no data)	0.541	No data were transmitted, Sniff interval = 500 ms
Connected+Sniff, Peripheral (no data)	0.551	No data were transmitted, Sniff interval = 500 ms
Data, Central	10.67	Data transmitted at 115200 bps, block size = 500

**Note 1:** Classic BR/EDR and RX\_IND functions are enabled.

**2:** The data correspond to the BM78SPPX5NC2 (ROM variant).

**TABLE 4-7: POWER CONSUMPTION – LOW ENERGY<sup>(1,2)</sup>**

Test Condition	Current Consumption (avg.) (mA)	Remarks
Deep Sleep Mode	0.13	—
LE Fast Advertising	1.21	LE fast advertising interval = 100 ms
	0.88	LE fast advertising interval = 160 ms
	0.48	LE fast advertising interval = 500 ms
	1.72	LE fast advertising interval = 100 ms + Beacon 100 ms
	0.62	LE fast advertising interval = 500 ms + Beacon 500 ms
Reduced Power Advertising	0.39	LE reduced power advertising interval = 961 ms
	1.00	LE reduced power advertising interval = 961 ms + Beacon 100 ms
	0.51	LE Reduced Power advertising interval = 961 ms+Beacon 500 ms
Connected (No data)	0.39	Connection interval = 1500 ms
	0.43	Connection interval = 600 ms
Connected (iPhone® 6 to module)	0.45	Connection interval = 500 ms
	0.60	Connection interval = 200 ms
Connected (module to iPhone 6)	6.6	Connection interval = 500 ms
	7.0	Connection interval = 200 ms

**Note 1:** Low energy, RX\_IND function is enabled.

**2:** The data correspond to the BM78SPPX5NC2 (ROM variant).

## 5.0 RADIO CHARACTERISTICS

The following table provides the transmitter performance characteristics of the BM78 module.

**TABLE 5-1: TRANSMITTER PERFORMANCE<sup>(1,2)</sup>**

Basic Data Rate	Min.	Typical	Max.	Bluetooth® Specification	Unit
BDR Power	—	1.5	—	-6 ~ +4	dBm
EDR (2M/3M) Power	—	-1	—	-6 ~ +4	
LE Power	—	0.5	—	-20 ~ +10	

**Note 1:** The RF transmit power can be calibrated during production by using the MP tool and the MT8852 Bluetooth test equipment.

**2:** Test condition: VCC RF = 1.80V, temperature = +25°C.

The following table provides the receiver performance characteristics of the BM78 module.

**TABLE 5-2: RECEIVER PERFORMANCE**

Basic Data Rate	Min.	Typical	Max.	Bluetooth® Specification	Unit
BDR Sensitivity	—	-90	—	≤-70	dBm
EDR 2M Sensitivity	—	-90	—		
EDR 3M Sensitivity	—	-82	—		
LE Sensitivity	—	-92	—		

**Note:** Test condition: VCC RF = 1.80V, temperature = +25°C.

## 6.0 PHYSICAL DIMENSIONS

The following figure illustrates the physical dimensions of the BM78SPPS5MC2/NC2 module.

**FIGURE 6-1: BM78SPPS5MC2/NC2 MODULE DIMENSIONS**

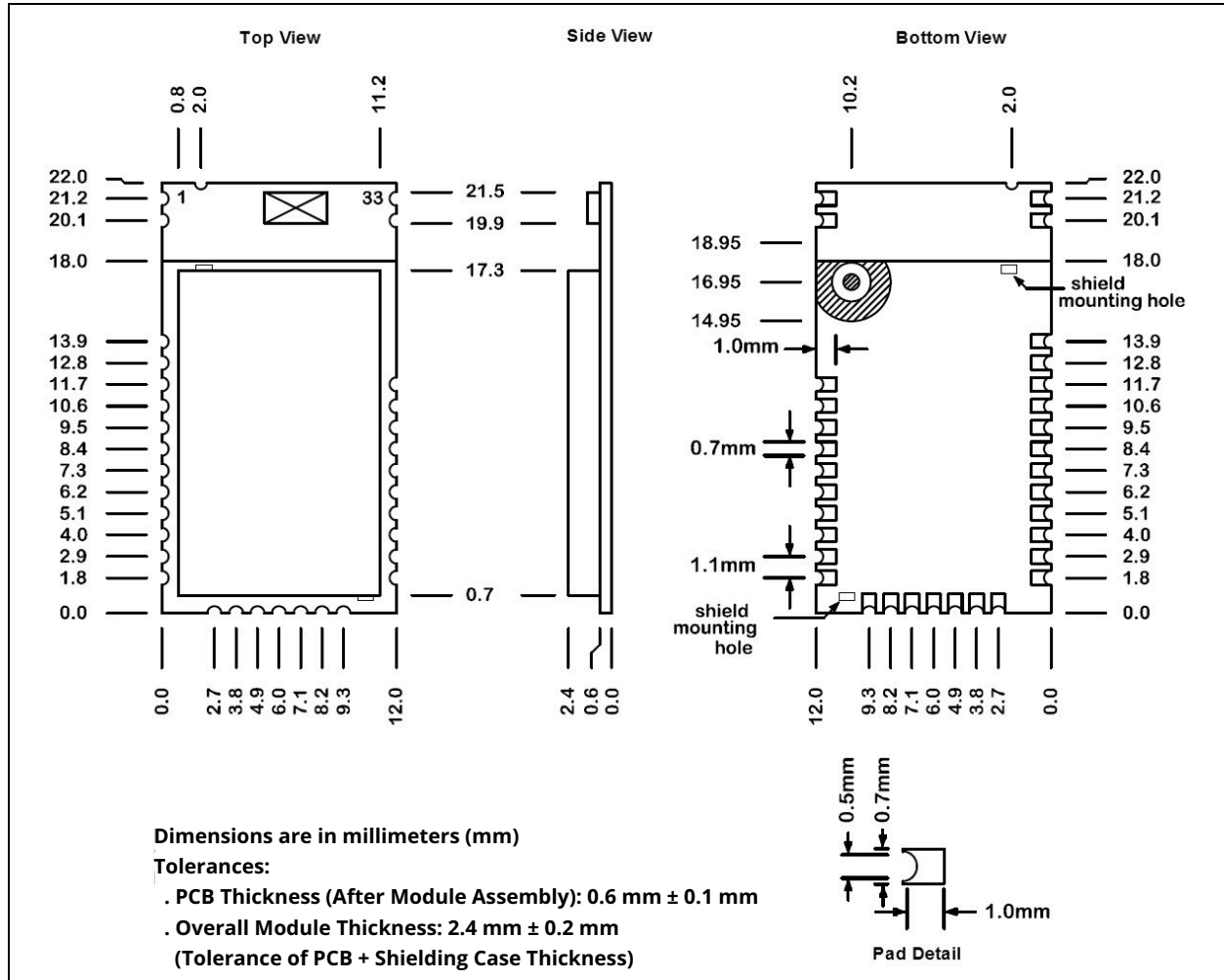

The following figure illustrates the recommended host PCB footprint.

**FIGURE 6-2: BM78SPPS5MC2/NC2 RECOMMENDED PCB FOOTPRINT**

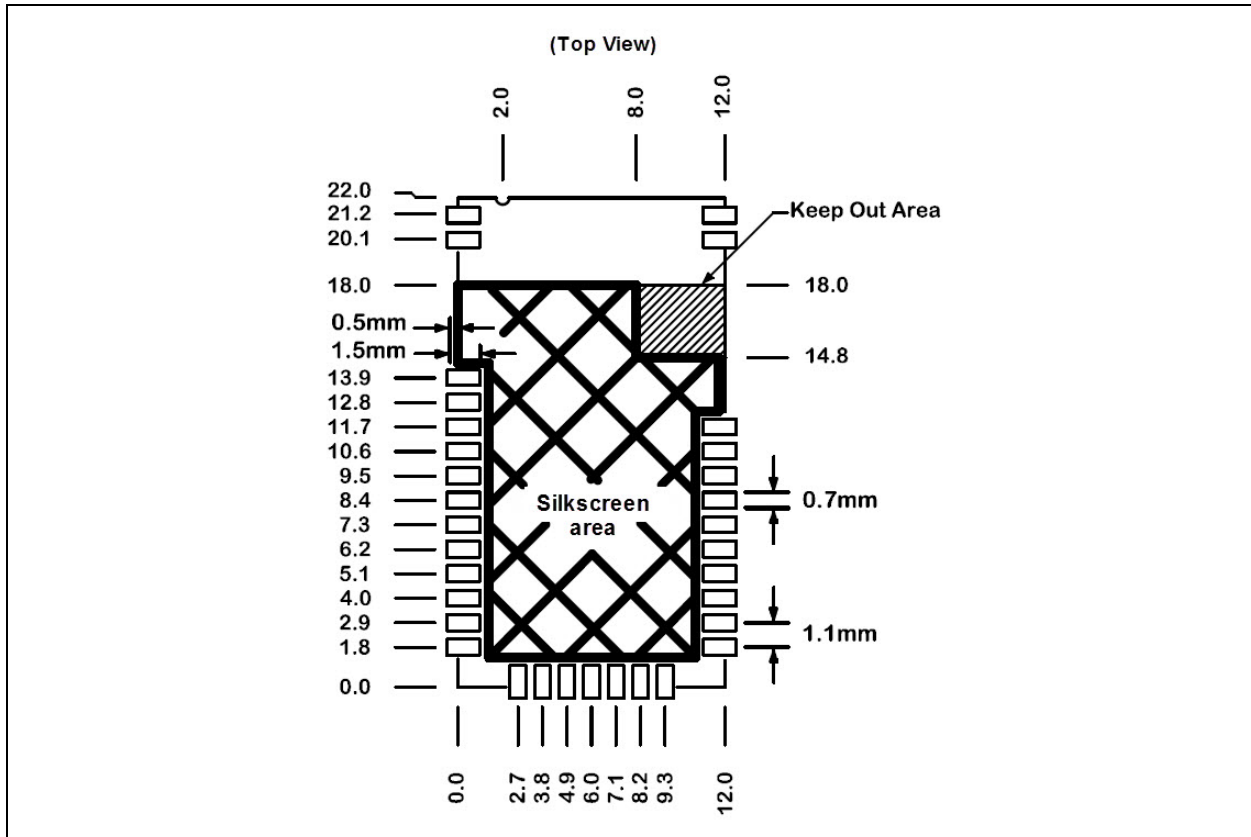

The following figure illustrates the recommendations for mounting the BM78SPPS5MC2/NC2 on the host PCB, and shows the minimum ground plane area to the left and right of the module for the best antenna performance.

Avoid the top copper layer near the test pin area. When designing the host PCB, the areas under the antenna should not contain any top, inner or bottom copper

layer. A low-impedance ground plane will ensure best radio performance (best range and lowest noise). The ground plane can be extended beyond the minimum recommended, as needed for host PCB EMC noise reduction. For best range performance, keep all external metal at least 31 mm away from the ceramic chip antenna.

**FIGURE 6-3: BM78SPPS5MC2/NC2 HOST PCB MOUNTING SUGGESTION**

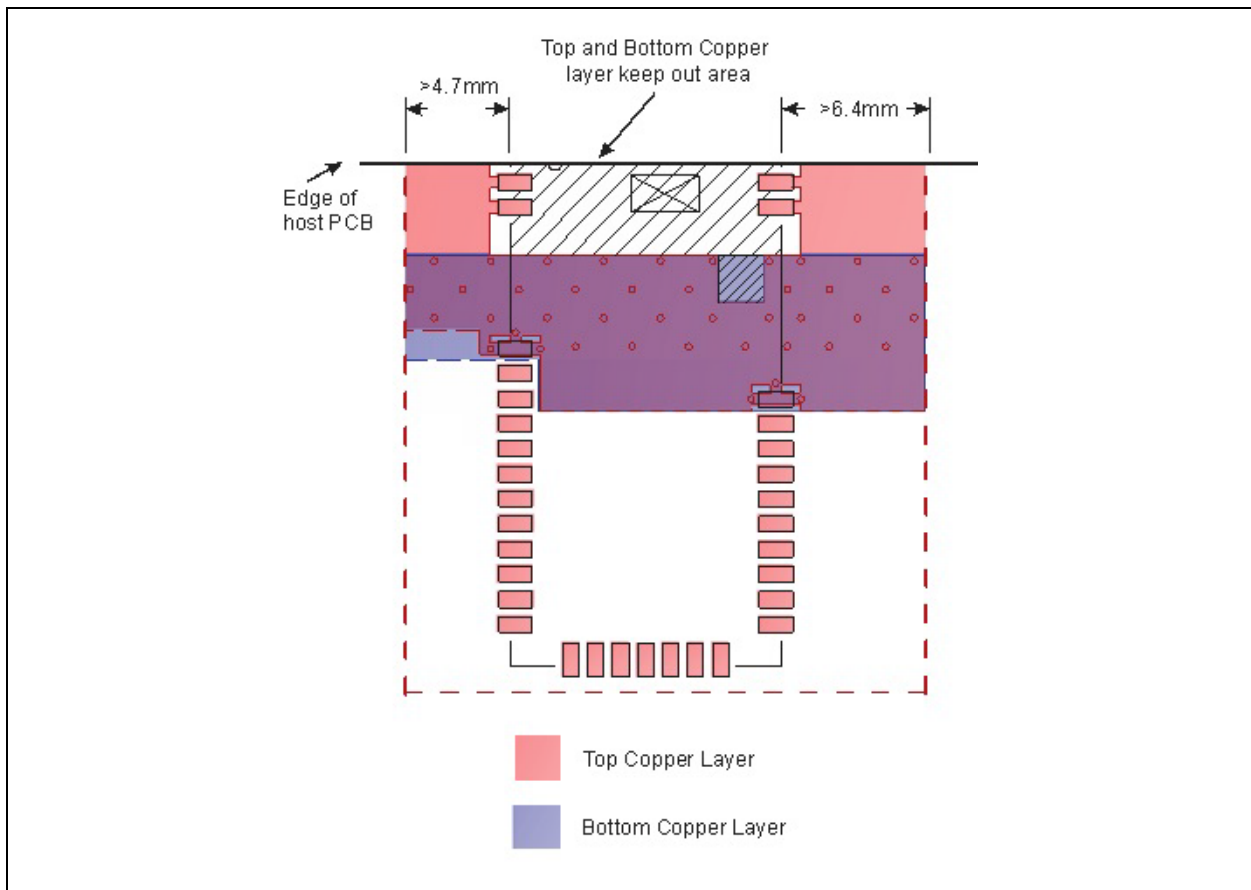

The following figure illustrates the physical dimensions of the BM78SPP05MC2/NC2 module.

**FIGURE 6-4: BM78SPP05MC2/NC2 MODULE DIMENSIONS**

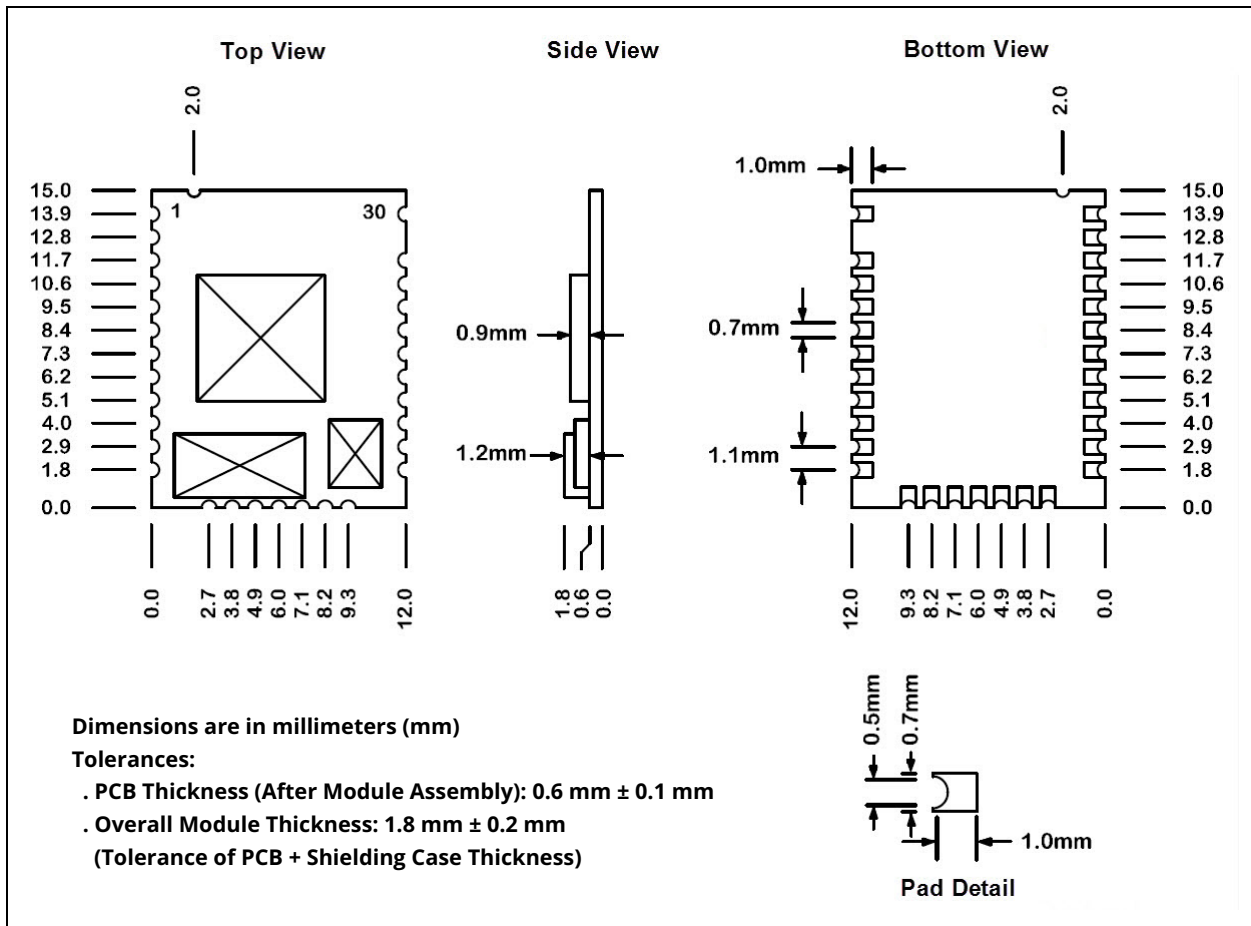

The following figure illustrates the recommended host PCB footprint.

**FIGURE 6-5: BM78SPP05MC2/NC2 RECOMMENDED PCB FOOTPRINT**

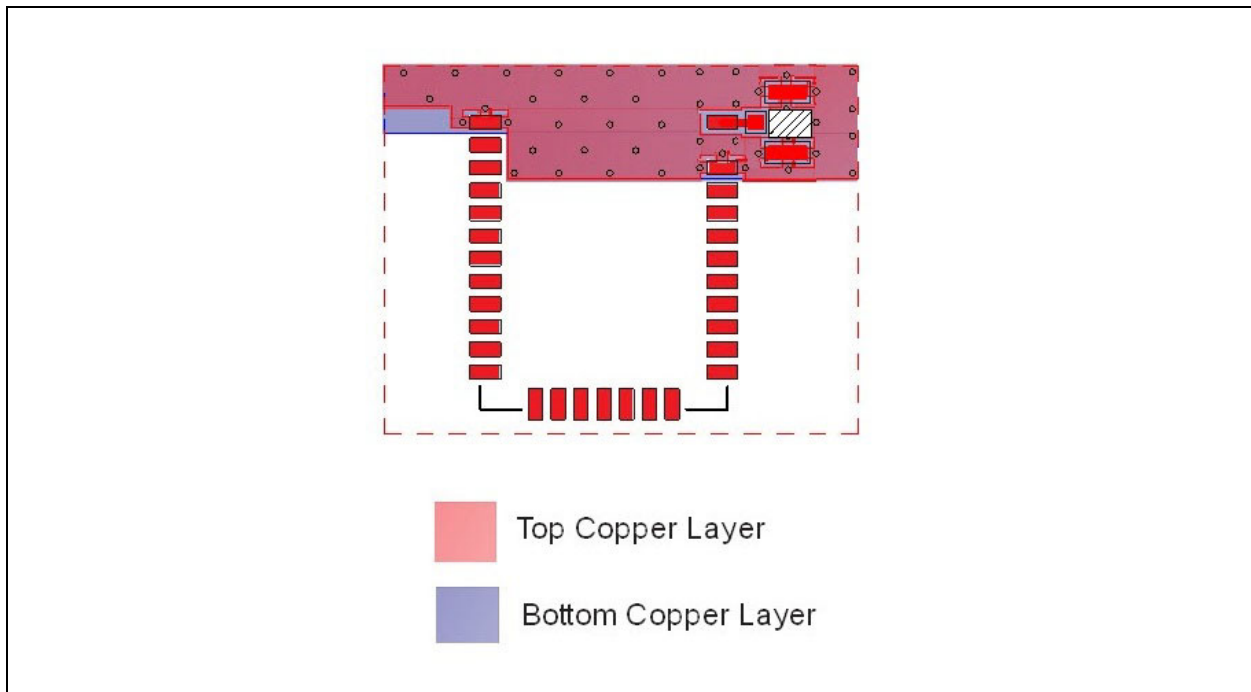

The following figure illustrates the recommended mounting details for the BM78SPP05MC2/NC2 module and recommended layout of the host PCB.

A low-impedance ground plane will ensure best radio performance (best range, lowest noise). The pin 30 (BT\_RF) is a 50 Ohm connection to an external antenna connector, PCB trace antenna or component (ceramic chip) antenna through a host PCB with

50 Ohm impedance and micro-strip trace. This trace can be extended to include passive parts for antenna attenuation padding, impedance matching or to provide test posts. It is recommended that the micro-strip trace must be as short as possible for minimum loss and better impedance matching. If the micro-strip trace is longer, it must be a 50 Ohm impedance.

**FIGURE 6-6: BM78SPP05MC2/NC2 HOST PCB MOUNTING SUGGESTION**

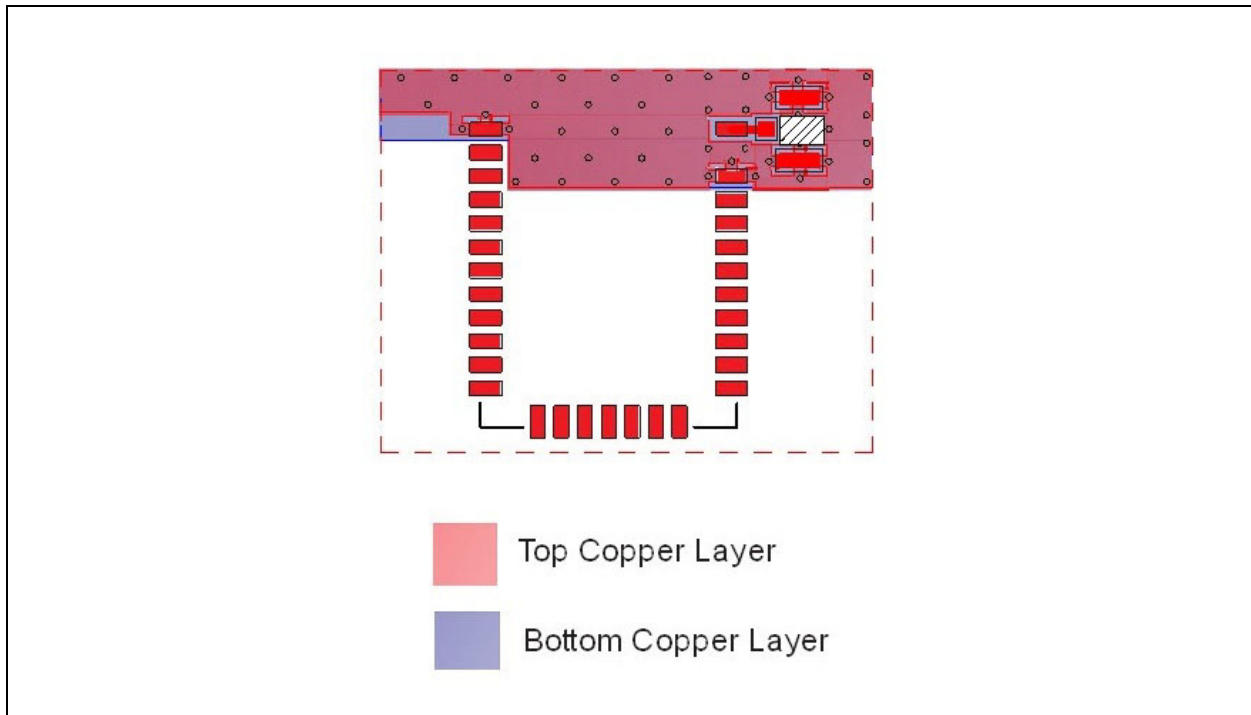

## 7.0 REFLOW PROFILE MODULE

The BM78 module is assembled using a standard lead-free reflow profile, IPC/JEDEC J-STD-020. The BM78 module can be soldered to the host PCB by using the standard leaded and lead-free solder reflow profiles.

To avoid damage to the module, follow these recommendations:

- Refer to AN233 "Solder Reflow Recommendation" application note (DS00233) for the soldering reflow recommendations.
- The peak temperature should not exceed ( $T_P$ ) of +250°C.
- Use no-clean flux solder paste.
- Do not wash the module as moisture can be trapped under the shield.
- Use only one flow. If the PCB requires multiple flows, apply the module on the final flow.

- Standard: IPC/JEDEC J-STD-020:
  - Condition: Preheat: +150°C to +200°C for 60 to 120 seconds
  - Average ramp-up rate (+217°C to peak): +3°C/sec max
  - Temperature maintained above +217°C: 60 to 150 seconds
  - Time within +5°C of peak temperature: 30 to 40 seconds
  - Peak temperature: +260°C with +5/0°C tolerance
  - Ramp-down rate (peak to +217°C): +6°C/sec max
  - Time within +25°C to peak temperature: 8 minutes max
  - Cycle interval: 5 minutes

The following figure illustrates the reflow profile of the BM78 module.

**FIGURE 7-1: REFLOW PROFILE**

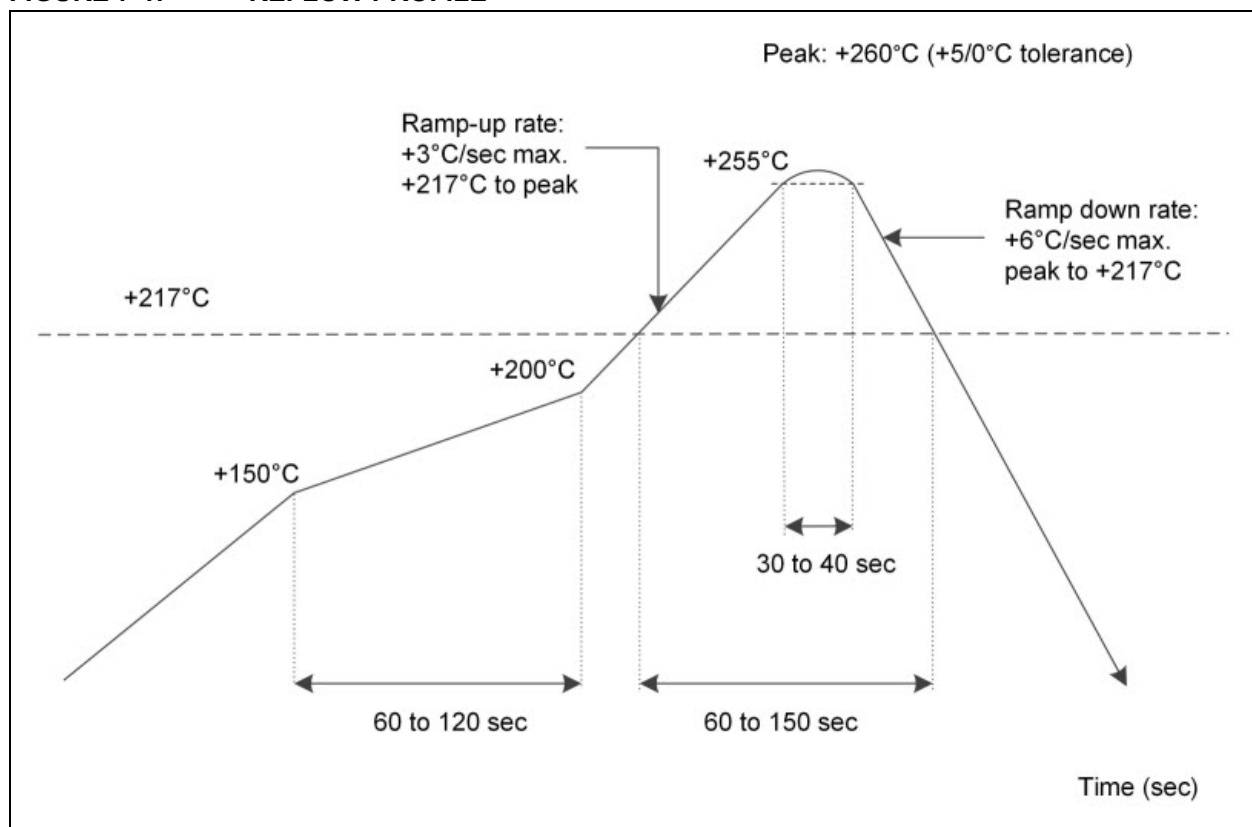

## 8.0 MODULE PLACEMENT GUIDELINES

For a Bluetooth wireless product, the antenna placement affects the performance of the whole system. The antenna requires free space to radiate the RF signal and it cannot be surrounded by the ground plane. Microchip recommends that the areas underneath the antenna on the host PCB do not contain copper on the top, inner or bottom layer.

The following figure illustrates an example of good and poor module placement on a host PCB with the ground plane.

The ground plane can be extended beyond the minimum recommendation, as required for the main PCB EMC noise reduction. For the best range performance, keep all external metal at least 15 mm away from the ceramic chip antenna.

**FIGURE 8-1: MODULE PLACEMENT EXAMPLES**

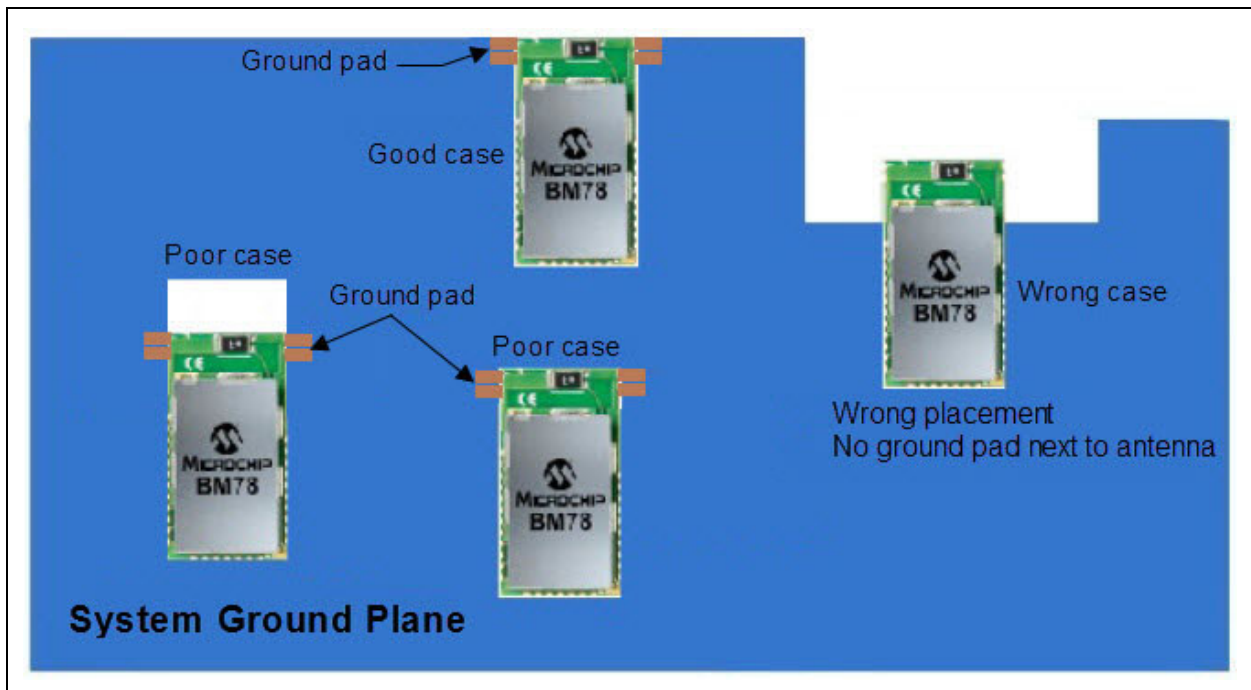
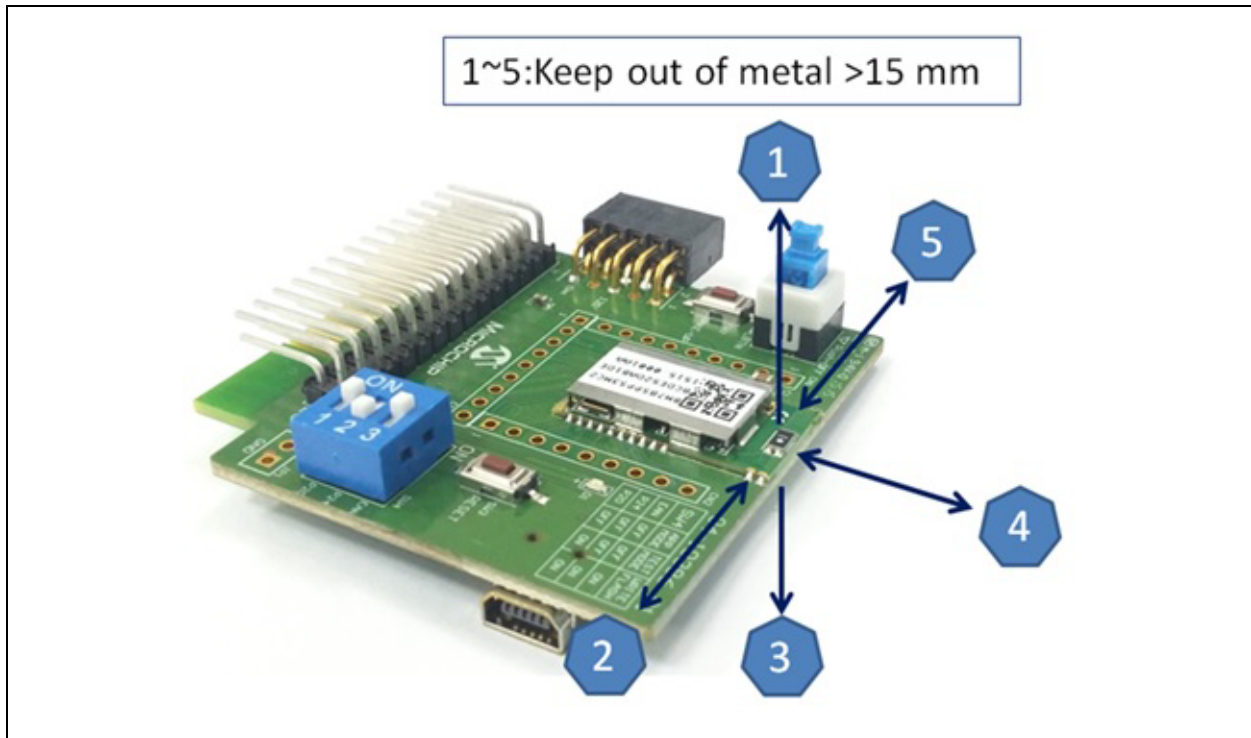

**TABLE 8-1: RECOMMENDED ANTENNA**

Description	Manufacturer Part Number	Manufacturer
ANT ANT3216A063R2400A, PIFA, 2.4 GHz, L3.2W1.6	ANT3216A063R2400A	Yageo Corp.

The following figure illustrates the BM78 module mounted on the BM78 Evaluation Board (EVB). It also shows the recommended keep out area for the antenna.

**FIGURE 8-2: KEEP OUT AREA RECOMMENDED FOR ANTENNA**



**Note:** For additional information on free space for antenna placement design, refer to the antenna manufacturer's design rule document.

## 8.1 BM78SPPS5MC2/NC2 Ceramic Chip Antenna

The BM78SPPS5MC2/NC2 contains an integral ceramic chip antenna. The following figure illustrates the antenna radiation pattern of the ceramic chip antenna on the BM78SPPS5MC2/NC2.

**FIGURE 8-3: BM78SPPS5MC2/NC2 ANTENNA RADIATION PATTERN**

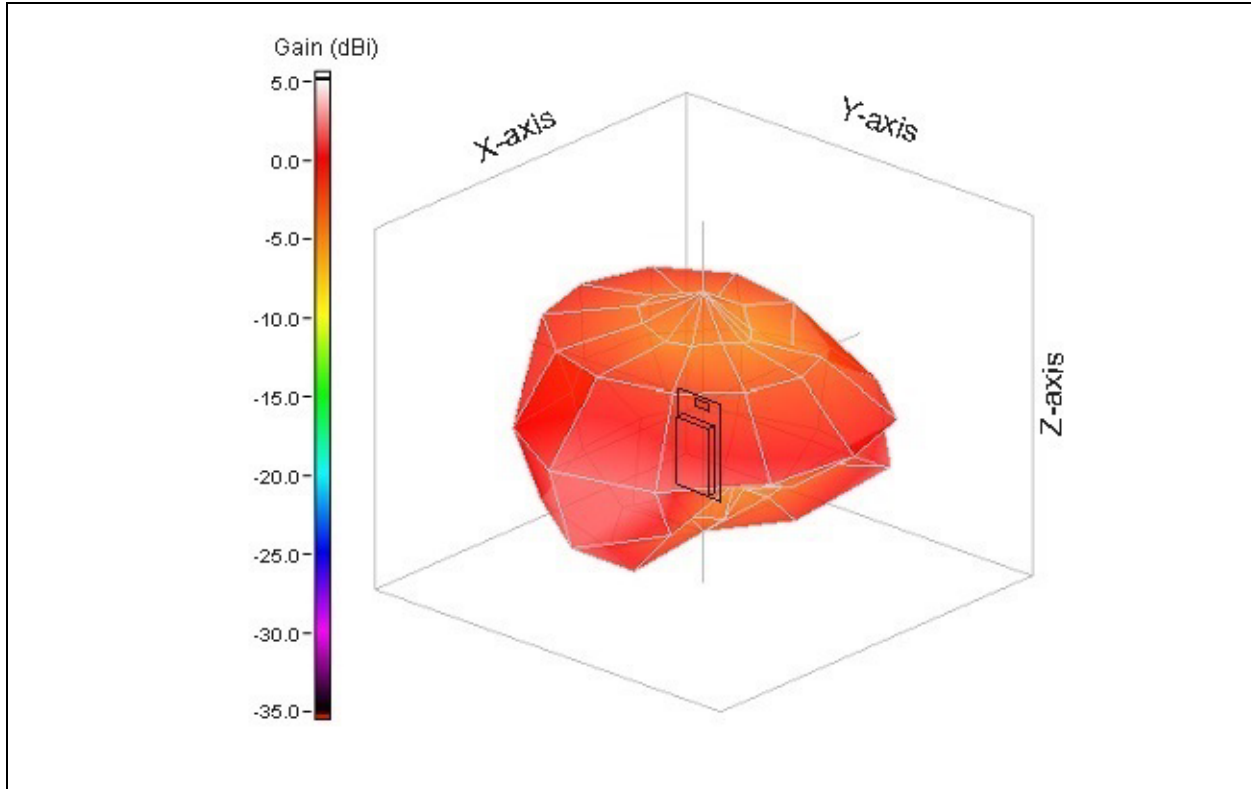

**TABLE 8-2: ANTENNA RADIATION PATTERN DETAILS**

Parameter	Values
Frequency	2450 MHz
Peak Gain	1.63 dBi
Efficiency	71.55%

## 9.0 ORDERING INFORMATION

The following table provides the various SKUs of the BM78 module.

**TABLE 9-1: BM78 MODULE SKUs**

Device	Microchip IC	Antenna	Description	Shield	Regulatory Certification	Ordering Number
BM78SPPS5MC2	IS1678SM-151	On-Board	Bluetooth® Dual mode, Class 2, Flash variant	Yes	FCC, ISED, CE, MIC, KCC, NCC, SRRC	BM78SPPS5MC2-0002AA
BM78SPP05MC2	IS1678SM-151	External	Bluetooth Dual mode, Class 2, Flash variant	No	No	BM78SPP05MC2-0002AA
BM78SPPS5NC2	IS1678S-152	On-Board	Bluetooth Dual mode, Class 2, ROM variant	Yes	FCC, ISED, CE, MIC, KCC, NCC	BM78SPPS5NC2-0002AA
BM78SPP05NC2	IS1678S-152	External	Bluetooth Dual mode, Class 2, ROM variant	No	No	BM78SPP05NC2-0002AA
BM78SPPS5MC2	IS1678SM-152	On-Board	Bluetooth Dual mode, Class 2, Flash variant, Firmware Rev 1.35	Yes	FCC, ISED, CE, MIC, KCC, NCC, SRRC	BM78SPPS5MC2-0004AA
BM78SPP05MC2	IS1678SM-152	External	Bluetooth Dual mode, Class 2, Flash variant, Firmware Rev 1.35	No	No	BM78SPP05MC2-0004AA

**Note:** The BM78 module can be purchased through a Microchip representative. Contact the Microchip sales office for information on Bluetooth v5.0 ROM variants of the BM78 module. Visit [www.microchip.com](http://www.microchip.com) for current pricing and a list of distributors for the product.

## APPENDIX A: CERTIFICATION NOTICES

The **BM78** module (BM78SPPS5MC2) has received regulatory approval for the following countries:

- Bluetooth SIG/QDID: 110108
- United States/FCC ID: A8TBM78ABCDEFGH
- Canada:
  - IC: 12246A-BM78SPPS5M2
  - HVIN: BM78SPPS5M2
  - PMN: Bluetooth Module
- Europe/CE
- Japan/MIC: 202-SMD070
- Korea/KCC: MSIP-CRM-mcp-BM78SPPS5MC2
- Taiwan/NCC No: CCAN15LP0510T4
- China/SRRC: CMIIT ID: 2015DJ7133

The **BM78 ROM** module (BM78SPPS5NC2) has received regulatory approval for the following countries:

- Bluetooth SIG/QDID: 110108
- United States/FCC ID: A8TBM78ABCDEFGH
- Canada:
  - IC: 12246A-BM78SPPS5M2
  - HVIN: BM78SPPS5M2
  - PMN: BM78SPPS5NC2
- Europe/CE
- Japan/MIC: 202-SMD070
- Korea/KCC: MSIP-CRM-mcp-BM78SPPS5MC2
- Taiwan/NCC No: CCAN18LP0800T1

### A.1 Regulatory Approval

This section outlines the regulatory information for the BM78 module for the following countries:

- United States
- Canada
- Europe
- Japan
- Korea
- Taiwan
- China
- Other Regulatory Jurisdictions

### A.1.1 UNITED STATES

The BM78/BM78 ROM module has received Federal Communications Commission (FCC) CFR47 Telecommunications, Part 15 Subpart C "Intentional Radiators" single modular approval in accordance with Part 15.212 Modular Transmitter approval. Single modular transmitter approval is defined as a complete RF transmission sub-assembly, designed to be incorporated into another device that must demonstrate compliance with FCC rules and policies, independent of any host. A transmitter with a modular grant can be installed in different end-use products (referred to as a host, host product or host device) by the grantee or other equipment manufacturer; then the host product may not require additional testing or equipment authorization for the transmitter function provided by that specific module or limited module device.

The user must comply with all of the instructions provided by the grantee, which indicate installation and/or operating conditions necessary for compliance.

The host product itself is required to comply with all applicable FCC equipment authorization regulations, requirements and equipment functions that are not associated with the transmitter module portion. For example, compliance must be demonstrated to regulations for other transmitter components within a host product; to requirements for unintentional radiators (Part 15 Subpart B), such as digital devices, computer peripherals, radio receivers, etc.; and to additional authorization requirements for the non-transmitter functions on the transmitter module (i.e., Verification, or Declaration of Conformity) (e.g., Bluetooth and Wi-Fi transmitter modules may also contain digital logic functions).

### A.1.2 LABELING AND USER INFORMATION REQUIREMENTS

The BM78/BM78 ROM module has been labeled with its own FCC ID number, and if the FCC ID is not visible when the module is installed inside another device, then the outside of the finished product into which the module is installed must also display a label referring to the enclosed module. This exterior label can use wording as follows:

Contains Transmitter Module  
FCC ID: A8TBM78ABCDEFGH

or

Contains FCC ID:A8TBM78ABCDEFGH

**This device complies with Part 15 of the FCC Rules. Operation is subject to the following two conditions: (1) this device may not cause harmful interference, and (2) this device must accept any interference received, including interference that may cause undesired operation.**

A user's manual for the product must include the following statement:

This equipment has been tested and found to comply with the limits for a Class B digital device, pursuant to Part 15 of the FCC Rules. These limits are designed to provide reasonable protection against harmful interference in a residential installation. This equipment generates, uses and can radiate radio frequency energy, and if not installed and used in accordance with the instructions, may cause harmful interference to radio communications. However, there is no guarantee that interference will not occur in a particular installation. If this equipment does cause harmful interference to radio or television reception, which can be determined by turning the equipment off and on, the user is encouraged to try to correct the interference by one or more of the following measures:

- Reorient or relocate the receiving antenna
- Increase the separation between the equipment and receiver
- Connect the equipment into an outlet on a circuit different from that to which the receiver is connected
- Consult the dealer or an experienced radio/TV technician for help

Additional information on labeling and user information requirements for Part 15 devices can be found in KDB Publication 784748, available at the FCC Office of Engineering and Technology (OET) Laboratory Division Knowledge Database (KDB): <http://apps.fcc.gov/oetcf/kdb/index.cfm>.

## A.1.3 RF EXPOSURE

All transmitters regulated by FCC must comply with RF exposure requirements. KDB 447498 General RF Exposure Guidance provides guidance in determining whether proposed or existing transmitting facilities, operations or devices comply with limits for human exposure to Radio Frequency (RF) fields adopted by the Federal Communications Commission (FCC).

From the FCC Grant: Output power listed is conducted. This grant is valid only when the module is sold to OEM integrators and must be installed by the OEM or OEM integrators. This transmitter is restricted for use with the specific antenna(s) tested in this application for Certification and must not be co-located or operating in conjunction with any other antenna or transmitters within a host device, except in accordance with FCC multitransmitter product procedures.

## A.1.4 APPROVED ANTENNAS

To maintain modular approval in the United States, only the antenna types that have been tested shall be used. It is permissible to use different antennas, provided the same antenna type, antenna gain (equal to or less than), with similar in-band and out-of band characteristics (refer to specification sheet for cutoff frequencies).

For BM78, the approval is received using the antenna listed in [Table 8-1](#).

## A.1.5 HELPFUL WEBSITES

Federal Communications Commission (FCC): <http://www.fcc.gov>

FCC Office of Engineering and Technology (OET) Laboratory Division Knowledge Database (KDB): <http://apps.fcc.gov/oetcf/kdb/index.cfm>

## A.2 Canada

The BM78/BM78 ROM module has been certified for use in Canada under Innovation, Science and Economic Development Canada (ISED, formerly Industry Canada) Radio Standards Procedure (RSP) RSP-100, Radio Standards Specification (RSS) RSS-Gen and RSS-247. Modular approval permits the installation of a module in a host device without the need to recertify the device.

### A.2.1 LABELING AND USER INFORMATION REQUIREMENTS

Labeling Requirements (from RSP-100, Issue 12, Section 5): The host product shall be properly labeled to identify the module within the host device.

The Innovation, Science and Economic Development Canada certification label of a module shall be clearly visible at all times when installed in the host product; otherwise, the host device must be labeled to display the Innovation, Science and Economic Development Canada certification number of the module, preceded by the word "Contains", or similar wording expressing the same meaning, as follows:

Contains IC: 12246A-BM78SPPS5M2

User Manual Notice for License-Exempt Radio Apparatus (from Section 8.4 RSS-Gen, Issue 5, March 2019): User manuals for license-exempt radio apparatus shall contain the following or equivalent notice in a conspicuous location in the user manual or alternatively, on the device or both:

This device contains license-exempt transmitter(s)/ receiver(s) that comply with Innovation, Science and Economic Development Canada's license-exempt RSS(s). Operation is subject to the following two conditions:

1. This device may not cause interference;
2. This device must accept any interference, including interference that may cause undesired operation of the device.

L'émetteur/récepteur exempt de licence contenu dans le présent appareil est conforme aux CNR d'Innovation, Sciences et Développement économique Canada applicables aux appareils radio exempts de licence. L'exploitation est autorisée aux deux conditions suivantes:

1. L'appareil ne doit pas produire de brouillage;
2. L'appareil doit accepter tout brouillage radioélectrique subi, même si le brouillage est susceptible d'en compromettre le fonctionnement.

Transmitter Antenna (from Section 6.8 RSS-GEN, Issue 5, March 2019): User manuals, for transmitters shall display the following notice in a conspicuous location:

This radio transmitter [IC: 12246A-BM78SPPS5M2] has been approved by Innovation, Science and Economic Development Canada to operate with the antenna types listed below, with the maximum permissible gain indicated. Antenna types not included in this list that have a gain greater than the maximum gain indicated for any type listed are strictly prohibited for use with this device.

Le présent émetteur radio [IC: 12246A-BM78SPPS5M2] a été approuvé par Innovation, Sciences et Développement économique Canada pour fonctionner avec les types d'antenne énumérés cidessous et ayant un gain admissible maximal. Les types d'antenne non inclus dans cette liste, et dont le gain est supérieur au gain maximal indiqué pour tout type figurant sur la liste, sont strictement interdits pour l'exploitation de l'émetteur.

Immediately following the above notice, the manufacturer shall provide a list of all antenna types approved for use with the transmitter, indicating the maximum permissible antenna gain (in dBi) and required impedance for each.

## A.2.2 RF EXPOSURE

All transmitters regulated by the Innovation, Science and Economic Development Canada (ISED) must comply with RF exposure requirements listed in RSS-102 - Radio Frequency (RF) Exposure Compliance of Radio Communication Apparatus (All Frequency Bands).

This transmitter is restricted for use with a specific antenna tested in this application for certification, and must not be co-located or operating in conjunction with any other antenna or transmitters, except in accordance with Innovation, Science and Economic Development Canada multitransmitter guidelines.

The device operates at an output power level which is within the ISED SAR test exemption limits at any user distance.

## A.2.3 APPROVED ANTENNAS

For BM78, the approval is received using the antenna listed in [Table 8-1](#).

## A.2.4 HELPFUL WEBSITES

Innovation, Science and Economic Development Canada (ISED): <http://www.ic.gc.ca/>.

## A.3 Europe

The BM78/BM78 ROM module is Radio Equipment Directive (RED) assessed, CE marked, and has been manufactured and tested with the intention of being integrated into a final product.

The BM78/BM78 ROM module has been tested to RED 2014/53/EU Essential Requirements mentioned in the following European Compliance table.

**TABLE 0-1: EUROPEAN COMPLIANCE**

Certification	Standards	Article
Safety	EN 62368	3.1(a)
Health	EN 62311	
Electromagnetic Compatibility (EMC)	EN 301 489-1	3.1(b)
	EN 301 489-17	
Radio	EN300 328	3.2

The ETSI provides guidance on modular devices in "Guide to the application of harmonised standards covering Article 3.1(b) and Article 3.2 of the Directive 2014/53/EU RED to multi-radio and combined radio and non-radio equipment" document available at: [http://www.etsi.org/deliver/etsi\\_eg/203300\\_203399/203367/01.01.01\\_60/eg\\_203367v010101p.pdf](http://www.etsi.org/deliver/etsi_eg/203300_203399/203367/01.01.01_60/eg_203367v010101p.pdf).

**Note:** To maintain conformance to the standards listed in the preceding European Compliance table, the module shall be installed in accordance with the installation instructions in this data sheet and shall not be modified. When integrating a radio module into a completed product, the integrator becomes the manufacturer of the final product and is therefore, responsible for demonstrating compliance of the final product with the essential requirements against the RED.

## A.3.1 LABELING AND USER INFORMATION REQUIREMENTS

The label on the final product which contains the BM78/BM78 ROM module must follow CE marking requirements.

## A.3.2 CONFORMITY ASSESSMENT

From ETSI Guidance Note EG 203367, Section 6.1, non-radio products are combined with a radio product:

If the manufacturer of the combined equipment installs the radio product in a host non-radio product in equivalent assessment conditions (i.e., host equivalent to the one used for the assessment of the radio product) and according to the installation instructions for the radio product, then no additional assessment of the combined equipment against Article 3.2 of the RED is required.

## A.3.3 APPROVED ANTENNAS

For BM78/BM78 ROM, the approval is received using the antenna shown in [Table 8-1](#).

### A.3.3.1 Simplified EU Declaration of Conformity

Hereby, Microchip Technology Inc. declares that the radio equipment type BM78/BM78 ROM is in compliance with Directive 2014/53/EU.

The full text of the EU declaration of conformity for this product is available at: <https://www.microchip.com/wwwproducts/en/BM78> (available under *Documents > Certifications*).

## A.3.4 HELPFUL WEBSITES

A document that can be used as a starting point in understanding the use of Short Range Devices (SRD) in Europe is the European Radio Communications Committee (ERC) Recommendation 70-03 E, which can be downloaded from the European Radio Communications Committee (ECC) at: <http://www.ecodocdb.dk/>.

Additional helpful websites are:

- Radio Equipment Directive (2014/53/EU): [https://ec.europa.eu/growth/single-market/european-standards/harmonised-standards/red\\_en](https://ec.europa.eu/growth/single-market/european-standards/harmonised-standards/red_en)
- European Conference of Postal and Telecommunications Administrations (CEPT): <http://www.cept.org>
- European Telecommunications Standards Institute (ETSI): <http://www.etsi.org>

The Radio Equipment Directive Compliance Association (REDCA): <http://www.redca.eu/>

## A.4 Japan

The BM78/BM78 ROM module has received type certification, and is labeled with its own technical conformity mark and certification number as required to conform to the technical standards regulated by the Ministry of Internal Affairs and Communications (MIC) of Japan pursuant to the Radio Act of Japan.

Integration of this module into a final product does not require additional radio certification, provided installation instructions are followed and no modifications of the module are allowed. Additional testing may be required.

If the host product is subject to electrical appliance safety (for example, powered from an AC mains), the host product may require Product Safety Electrical Appliance and Material (PSE) testing. The integrator must contact their conformance laboratory to determine if this testing is required

- There is a voluntary Electromagnetic Compatibility (EMC) test for the host product administered by VCCI: [http://www.vcci.jp/vcci\\_e/index.html](http://www.vcci.jp/vcci_e/index.html)

## A.4.1 LABELING AND USER INFORMATION REQUIREMENTS

The label on the final product which contains the BM78 module must follow Japan marking requirements. The integrator of the module must refer to the labeling requirements for Japan available at the Ministry of Internal Affairs and Communications (MIC) website.

The BM78 module is labeled with its own technical conformity mark and certification number. The final product in which this module is being used must have a label referring to the type certified module inside:

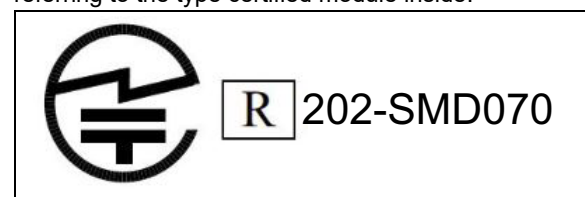

## A.4.2 HELPFUL WEBSITES

Ministry of Internal Affairs and Communications (MIC): <http://www.tele.soumu.go.jp/e/index.htm>

Association of Radio Industries and Businesses (ARIB): <http://www.arib.or.jp/english/>

## A.5 Korea

The BM78/BM78 ROM module has received certification of conformity in accordance with the Radio Waves Act. Integration of this module into a final product does not require additional radio certification provided installation instructions are followed and no modifications of the module are allowed.

### A.5.1 LABELING AND USER INFORMATION REQUIREMENTS

The label on the final product which contains the BM78/BM78 ROM module must follow KC marking requirements. The integrator of the module must refer to the labeling requirements for Korea available on the Korea Communications Commission (KCC) website.

The BM78 module is labeled with its own KC mark. The final product requires the KC mark and certificate number of the module:

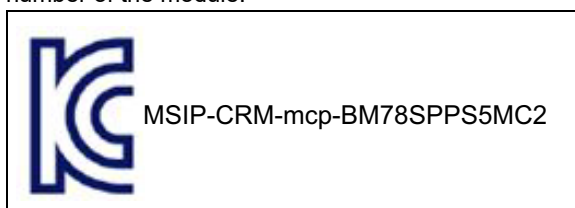

### A.5.2 HELPFUL WEBSITES

Korea Communications Commission (KCC):  
<http://www.kcc.go.kr>

National Radio Research Agency (RRA):  
<http://rra.go.kr>

## A.6 Taiwan

The BM78/BM78 ROM module has received compliance approval in accordance with the Telecommunications Act. Customers seeking to use the compliance approval in their product must contact Microchip Technology Inc. sales or distribution partners to obtain a Letter of Authority.

Integration of this module into a final product does not require additional radio certification, provided installation instructions are followed and no modifications of the module are allowed.

### A.6.1 LABELING AND USER INFORMATION REQUIREMENTS

For the BM78 module, due to limited module size, the NCC mark and ID are displayed in the data sheet and/or packaging and cannot be displayed on the module label:

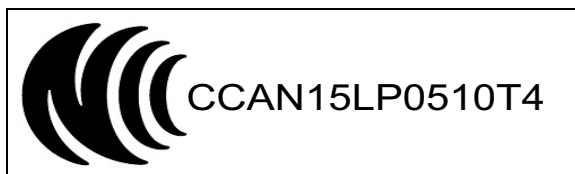

For the BM78 ROM module, due to limited module size, the NCC mark and ID are displayed in the data sheet and/or packaging and cannot be displayed on the module label:

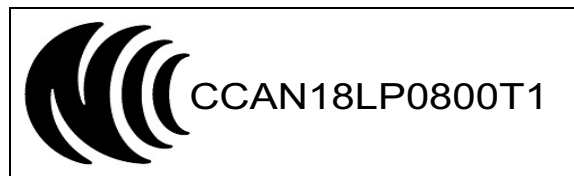

The user's manual must contain the below warning (for RF device) in traditional Chinese:

注意！

依據 低功率電波輻射性電機管理辦法

第十二條 經型式認證合格之低功率射頻電機，非經許可，

公司、商號或使用者均不得擅自變更頻率、加大功率或變更原設計

之特性及功能。

第十四條 低功率射頻電機之使用不得影響飛航安全及干擾合法通信；

經發現有干擾現象時，應立即停用，並改善至無干擾時方得繼續使用。

前項合法通信，指依電信規定作業之無線電信。

低功率射頻電機須忍受合法通信或工業、科學及醫療用電波輻射性

電機設備之干擾。

### A.6.2 HELPFUL WEBSITES

National Communications Commission (NCC):  
<http://www.ncc.gov.tw>

## A.7 China

The BM78 module has received a certification of conformity in accordance with the China MIIT Notice 2014-01 of State Radio Regulation Committee (SRRC) certification scheme under Full Modular Approval (FMA). Integration of this module into a final product does not require additional radio certification, provided that the installation instructions are followed and no modifications of the module are allowed. Refer to the SRRC certificate available on the BM78 module product page under "Regulatory Approval Documentation Package" for the expiry date.

### A.7.1 LABELING AND USER INFORMATION REQUIREMENTS

The BM78 module is labeled with its own CMIIT ID as follows:

CMIIT ID: 2015DJ7133

Equipment Name 设备名称: 蓝牙模块

Equipment Type 设备型号: BM78

CMIIT ID 核准代码: 2015DJ7133

When the host system (end product) equipped with Full Modular Approval (FMA) module, the end product label or user manual should bear CMIIT ID information in Simplified Chinese (本设备包含型号核准代码(分别)为: CMIIT ID: 2015DJ7133, ... 的无线电发射模块。).

## A.8 UKCA (UK Conformity Assessed)

The BM78/BM78 ROM module is a UK conformity assessed radio module that meets all the essential requirements according to CE RED requirements.

### A.8.1 LABELING REQUIREMENTS FOR MODULE AND USER'S REQUIREMENTS

The label on the final product that contains the BM78/BM78 ROM module must follow the UKCA marking requirements.



The UKCA mark above is printed on the module itself or on the packing label.

Additional details for the label requirement are available at:

<https://www.gov.uk/guidance/using-the-ukca-marking#check-whether-you-need-to-use-the-new-ukca-marking>.

### A.8.2 UKCA DECLARATION OF CONFORMITY

Hereby, Microchip Technology Inc. declares that the radio equipment type BM78/BM78 ROM module is in compliance with the Radio Equipment Regulations 2017.

The full text of the UKCA declaration of conformity for this product is available (under *Documents > Certifications*) at:

- <https://www.microchip.com/en-us/product/BM78>

### A.8.3 APPROVED ANTENNAS

The testing of the BM78/BM78 ROM module was performed with the antennas listed in [Table 8-2](#).

### A.8.4 HELPFUL WEB SITES

For more information on the UKCA regulatory approvals, refer to the <https://www.gov.uk/guidance/placing-manufactured-goods-on-the-market-in-great-britain>.

## A.9 Other Regulatory Information

- For information on the other country jurisdictions covered, refer to: <http://www.microchip.com/design-centers/wireless-connectivity>.
- Should other regulatory jurisdiction certification be required by the customer, or the customer needs to recertify the module for other reasons, contact Microchip for the required utilities and documentation.

## APPENDIX B: REVISION HISTORY

### Revision F (March 2026)

**TABLE F-1: MAJOR SECTION UPDATES**

Section	Update Description
Document	Updated to latest template.
<a href="#">6.0 “Physical Dimensions”</a>	Updated <a href="#">Figure 6-1</a> and <a href="#">Figure 6-4</a> with tolerance information.
<a href="#">A.7 “China”</a>	<ul style="list-style-type: none"> <li>Updated to the latest template.</li> <li>China/SRRC certification status for the BM78 ROM module is not active.</li> </ul>

### Revision E (July 2022)

**TABLE E-2: MAJOR SECTION UPDATES**

Section	Update Description
<a href="#">A.8 “UKCA (UK Conformity Assessed)”</a>	Added UKCA regulatory approval information.

### Revision D (March 2021)

- Updated [Table 1-1](#).
- Updated [A.2.1 “Labeling and User Information Requirements”](#) and [A.3 “Europe”](#).
- Added [A.4.1 “Labeling and User Information Requirements”](#) and [A.2.3 “Approved Antennas”](#).
- Updated with the new terminologies. For more details, see the following note.

**Note:** Microchip is aware that some terminologies used in the technical documents and existing software codes of this product are outdated and unsuitable. This document may use these new terminologies, which may or may not reflect on the source codes, software GUIs and the documents referenced within this document. The following table shows the relevant terminology changes made in this document.

**TABLE D-3: TERMINOLOGY RELATED CHANGES**

Old Terminology	New Terminology	Description
Master	Central	<a href="#">Table 4-6</a> updated with new terminology change.
Slave	Peripheral	<a href="#">Table 4-6</a> updated with new terminology change.

### Revision C (February 2020)

This revision includes the following minor update:  
Updated [Figure 6-1](#).

### Revision B (April 2019)

This revision includes the following changes and minor updates to text and formatting, which were incorporated throughout the document.

**TABLE B-1: MAJOR SECTION UPDATES**

Section	Update Description
Document	Updated Bluetooth version from 4.2 to 5.0.
<a href="#">“Features”</a>	<ul style="list-style-type: none"> <li>Updated certification information.</li> <li>Updated <a href="#">Figure 1</a>.</li> </ul>
<a href="#">“Data Throughput”</a>	Updated Kbytes/s.
<a href="#">1.0“System Overview”</a>	Updated <a href="#">Table 1-1</a> , <a href="#">Figure 1-1</a> and <a href="#">Figure 1-3</a> .
<a href="#">2.0“Application Information”</a>	Added <a href="#">Table 2-3</a> . Updated <a href="#">Table 2-2</a> , <a href="#">Figure 2-1</a> and <a href="#">Figure 2-8</a> .
<a href="#">3.0“Operating Modes”</a>	Updated this section.

---

---

Section	Update Description
<a href="#">4.0“Electrical Characteristics”</a>	Updated Storage temperature.
<a href="#">6.0“Physical Dimensions”</a>	Updated <a href="#">Figure 6-1</a> , <a href="#">Figure 6-2</a> , <a href="#">Figure 6-4</a> and <a href="#">Figure 6-5</a> .
<a href="#">8.0“Module Placement Guidelines”</a>	Updated <a href="#">Figure 8-1</a> .
<a href="#">9.0“Ordering Information”</a>	Updated <a href="#">Table 9-1</a> with certification information and added two part numbers.
<a href="#">Appendix A:“Certification Notices”</a>	Updated this section.

## Revision A (January 2016)

- This is the initial released version of this document.

---

---

## Microchip Information

### Trademarks

The “Microchip” name and logo, the “M” logo, and other names, logos, and brands are registered and unregistered trademarks of Microchip Technology Incorporated or its affiliates and/or subsidiaries in the United States and/or other countries (“Microchip Trademarks”). Information regarding Microchip Trademarks can be found at <https://www.microchip.com/en-us/about/legal-information/microchip-trademarks>.

ISBN: 979-8-3371-2990-7

### Legal Notice

This publication and the information herein may be used only with Microchip products, including to design, test, and integrate Microchip products with your application. Use of this information in any other manner violates these terms. Information regarding device applications is provided only for your convenience and may be superseded by updates. It is your responsibility to ensure that your application meets with your specifications. Contact your local Microchip sales office for additional support or, obtain additional support at [www.microchip.com/en-us/support/design-help/client-support-services](http://www.microchip.com/en-us/support/design-help/client-support-services).

THIS INFORMATION IS PROVIDED BY MICROCHIP "AS IS". MICROCHIP MAKES NO REPRESENTATIONS OR WARRANTIES OF ANY KIND WHETHER EXPRESS OR IMPLIED, WRITTEN OR ORAL, STATUTORY OR OTHERWISE, RELATED TO THE INFORMATION INCLUDING BUT NOT LIMITED TO ANY IMPLIED WARRANTIES OF NON-INFRINGEMENT, MERCHANTABILITY, AND FITNESS FOR A PARTICULAR PURPOSE, OR WARRANTIES RELATED TO ITS CONDITION, QUALITY, OR PERFORMANCE.

IN NO EVENT WILL MICROCHIP BE LIABLE FOR ANY INDIRECT, SPECIAL, PUNITIVE, INCIDENTAL, OR CONSEQUENTIAL LOSS, DAMAGE, COST, OR EXPENSE OF ANY KIND WHATSOEVER RELATED TO THE INFORMATION OR ITS USE, HOWEVER CAUSED, EVEN IF MICROCHIP HAS BEEN ADVISED OF THE POSSIBILITY OR THE DAMAGES ARE FORESEEABLE. TO THE FULLEST EXTENT ALLOWED BY LAW, MICROCHIP'S TOTAL LIABILITY ON ALL CLAIMS IN ANY WAY RELATED TO THE INFORMATION OR ITS USE WILL NOT EXCEED THE AMOUNT OF FEES, IF ANY, THAT YOU HAVE PAID DIRECTLY TO MICROCHIP FOR THE INFORMATION.

Use of Microchip devices in life support and/or safety applications is entirely at the buyer's risk, and the buyer agrees to defend, indemnify and hold harmless Microchip from any and all damages, claims, suits, or expenses resulting from such use. No licenses are conveyed, implicitly or otherwise, under any Microchip intellectual property rights unless otherwise stated.

### Microchip Devices Code Protection Feature

Note the following details of the code protection feature on Microchip products:

- Microchip products meet the specifications contained in their particular Microchip Data Sheet.
- Microchip believes that its family of products is secure when used in the intended manner, within operating specifications, and under normal conditions.
- Microchip values and aggressively protects its intellectual property rights. Attempts to breach the code protection features of Microchip product is strictly prohibited and may violate the Digital Millennium Copyright Act.
- Neither Microchip nor any other semiconductor manufacturer can guarantee the security of its code. Code protection does not mean that we are guaranteeing the product is “unbreakable”. Code protection is constantly evolving. Microchip is committed to continuously improving the code protection features of our products.