

**Part Number:** 1812JA250122MJRUYS

**Description:** 1812 250Vac (Y2), 305Vac (X1), 50/60Hz / 2500Vdc 1.2nF ±20% X7R (2R1)

**Approval Specifications:** IEC/EN60384-14:2023  
UL60384-14, CAN/CSA E60384-14:14

**Certification:** Unmarked parts are uncertified but manufactured in accordance with the above specifications.

**Classification:** These capacitors comply with the requirements of IEC/EN 60384-14:2023 for Class Y2 / X1 for use in equipment within the spec of IEC62368

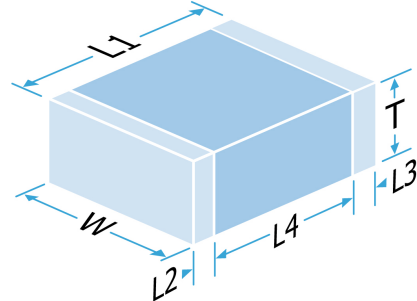

Component Marking and Certification Bodies:

Not Applicable

Material Group I : CTI >= 600

## Mechanical Specification

Size Code	1812
Length (L1) in mm (")	4.8 ± 0.35 (0.189 ± 0.014)
Width (W) in mm (")	3.2 ± 0.30 (0.126 ± 0.012)
Thickness (T) in mm (")	2.0 Max (0.08 Max)
Minimum Termination Band (L2,L3) in mm (")	0.30 (0.012)
Maximum Termination Band (L2,L3) in mm (")	0.80 (0.030)
Minimum Band Gap (L4) in mm (") (per IEC/EN 60384-14)	3.5 (0.138)
Termination Material	Nickel Barrier, Sn Plated Solder (RoHS compliant)
Solderability	IEC-60068-2-58
Packaging	13" Reel, 2000 per reel

## General Electrical Specification

Rated Voltage	Class Y2* (250Vac), Class X1* (305Vac), 50/60Hz, 5kV impulse (*Applicable to equipment within the scope of IEC 62368)
Humidity Grade	Grade IIIB (IEC/EN60384-14:2023 Annex I)
Maximum DC Working Voltage	2500Vdc (1000Vdc per IEC/EN60384-14:2023 Annex H)
Nominal Capacitance Value	1.2nF
Capacitance Tolerance	±20%
Tangent of Loss Angle (Tan δ)	≤0.025
Capacitance and Tan δ Test Conditions	1.0Vrms @ 1kHz
Voltage Proof (50mA max charging current for DC tests. 50% Max, RH)	100% test: 3000Vdc 1s min / 5s max AQL test: 3225Vdc / 2110Vac 60s min / 5kV 1.2x50µs impulse
Min Insulation Resistance (IR)	100.00GOhm @ 100Vdc
Dielectric Classification	X7R (2R1)
Rated Temperature Range	-55°C / +125°C
Maximum Capacitance Change over Temperature Range	No DC Voltage ±15% Rated DC Voltage -
Climatic Category (IEC)	55/125/56
Ageing Characteristic	<2% per decade (nominal capacitance is 1000 hour value)

### Knowles Precision Devices - Sales

Europe: KPD-Europe-sales@knowles.com

Asia: KPD-Asia-sales@knowles.com

USA: KPD-NA-sales@knowles.com

[www.knowlescapacitors.com](http://www.knowlescapacitors.com)

This datasheet is for a standard item and is confirmed valid on the date generated, the latest published data for this part may differ and is available at <http://www.knowlescapacitors.com> or by contacting us.

© The information contained on this drawing is confidential and may not be copied in whole or part in any form or disclosed to a third party without the consent of Knowles and any customer mentioned within this specification.

Data is correct to the best of our knowledge, errors and omissions excepted.

Date: Friday, May 15, 2026

20260515 053431391UTC

**Part Number:** 1812JA250122MJRUYS

**Description:** 1812 250Vac (Y2), 305Vac (X1), 50/60Hz / 2500Vdc 1.2nF ±20% X7R (2R1)

## Environmental

RoHS Compliant to 2011/65/EC as amended by 2015/863/EU	Compliant
REACH Compliant	250 compliant
California Proposition 65	No exposure risk

## Board Layout

Knowles' conventional 2-terminal chip capacitors can generally be mounted using pad designs in accordance with international specification IPC-7351, Generic Requirements for Surface Mount Design and Land Pattern Standards, but there are some other factors that have been shown to reduce mechanical stress, such as reducing the pad width to less than the chip width. In addition, the position of the chip on the board should be considered.

### IPC-7351 pad design

	1812	
C	5.30mm	0.209"
Y	1.50mm	0.059"
X	3.40mm	0.134"

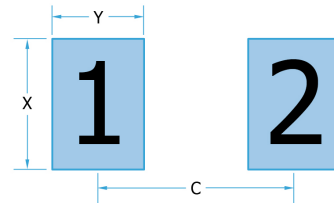

Some high voltage parts may require modifications to the board layout and/or the addition of a conformal coating to prevent flashover, especially under high humidity conditions. Board cleanliness and environmental conditions can also impact this. Refer to application note AN0043 for further information.

Dimensions given are for guidance. It is ultimately the customers responsibility to confirm that the circuit layout is in accordance with their own product requirements.

## Packaging

Tape packaging information for tape-and-reel parts:

Tape and reel packing of surface mounting chip capacitors for automatic placement are in accordance with IEC60286-3.

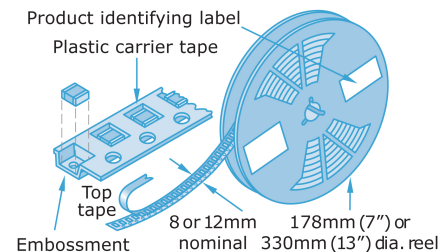

## Soldering

Reflow solder in accordance with IPC-A-610. Recommended reflow profile as laid down in IPC/JEDEC J-STD-020.

Wave soldering is also possible, but care must be taken for case sizes 1210 and larger and component thickness >1.0mm. Trials are encouraged.

Hand soldering is not recommended and can lead to component damage through thermal shock.

Application notes with mounting and handling guidance are available on request.

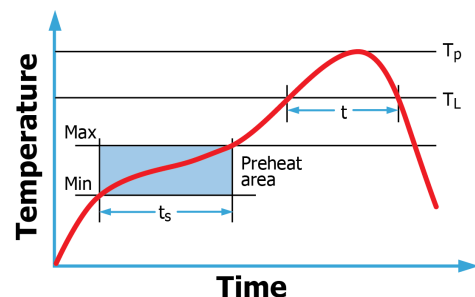

Compex      DLI      Johanson MFG      Novacap      Syfer      Voltronics

### Knowles Precision Devices - Sales

Europe: KPD-Europe-sales@knowles.com

Asia: KPD-Asia-sales@knowles.com

USA: KPD-NA-sales@knowles.com

[www.knowlescapacitors.com](http://www.knowlescapacitors.com)

This datasheet is for a standard item and is confirmed valid on the date generated, the latest published data for this part may differ and is available at <http://www.knowlescapacitors.com> or by contacting us.

© The information contained on this drawing is confidential and may not be copied in whole or part in any form or disclosed to a third party without the consent of Knowles and any customer mentioned within this specification.

Data is correct to the best of our knowledge, errors and omissions excepted.

Date: Friday, May 15, 2026

20260515 053431391UTC