

USB VBUS 3.3A Ideal Diode Load Switch with Current Limit

Features

- 2.5V to 5.5V Supply Voltage Range at IN
- 29V Abs. Max. Rating at OUT
- 53mΩ typ. On-Resistance from IN to OUT
- Adjustable Current Limit Protection (CLP)
 - ▶ 500mA to 3.3A via R_{ISET}
- Over-Current Protection (OCP)
- Short-Circuit Protection (SCP)
- “Ideal Diode” Reverse Current Protection (RCP)
- Over Temperature Protection (OTP)
- Soft-Start (SS) Limits Inrush Current
- Open-Drain \overline{FLT} Flag
- Safety approvals
 - ▶ UL 2367, File No. E515099
 - ▶ IEC 62368-1, File No. E515099
- -40°C to 85°C Operating Temperature Range
- RoHS and Green Compliant
- 9-bump WLCSP 1.31 x 1.31mm (0.4mm pitch)
- Pin-to-Pin with KTS1688 & FPF2495

Brief Description

The KTS1665 is a low-resistance load switch with adjustable current limit, soft-start, and “ideal diode” reverse current protection. It is optimized to protect systems with USB type-C ports that source up to 15W at 5V and must withstand up to 29V on VBUS.

The KTS1665 uses an external resistor to set the current limit from 500mA to 3.3A.

Soft-start limits inrush current and automatic “ideal diode” reverse current protection (RCP) isolates the system’s internal rail whenever VBUS is driven to a higher voltage, as when charging. A \overline{FLT} flag indicates an over-current or over-temperature fault condition.

The KTS1665 is available in advanced, fully “green” compliant, 1.31 x 1.31mm, 9-bump Wafer-Level Chip-Scale Package (WLCSP).

Applications

- Smartphones, Tablets, Gaming Consoles
- Notebooks, Ultra-Books, Desktop PCs
- Set-Top Box, Networking, any USB I_{SOURCE} Port

Typical Application

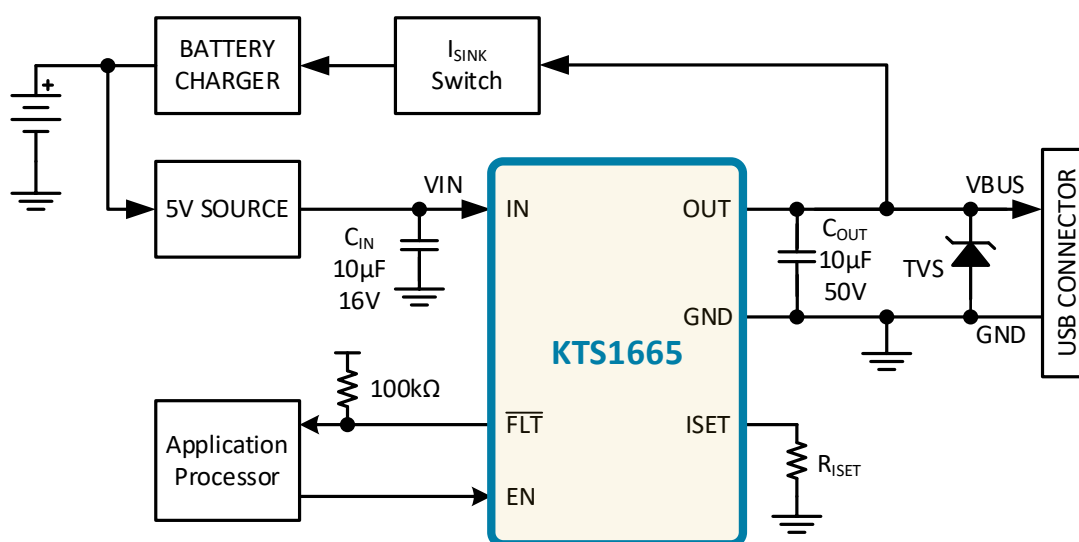

Ordering Information

Part Number	Marking ¹	Operating Temperature	Package
KTS1665ECAC-TA	SWXXYYZZZZ	-40°C to +85°C	WLCSP33-9

Pinout Diagram

WLCSP33-9

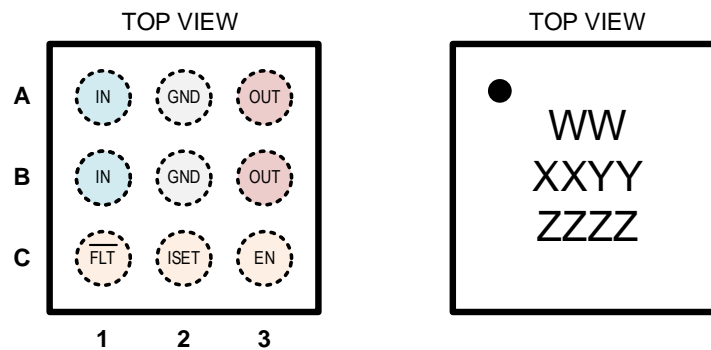

9-bump 1.31mm x 1.31mm x 0.555mm
WLCSP Package, 0.4mm pitch

Top Mark

WW = Device ID,
XX = Date Code, YY = Assembly Code,
ZZZZ = Serial Number

Pin Descriptions

Pin #	Name	Function
A1, B1	IN	Supply Input – input to the power switches
A2, B2	GND	Ground
A3, B3	OUT	Output of the power switches
C1	$\overline{\text{FLT}}$	Fault Logic Output – active-low, open-drain flag indicates OCP/CLP/SCP/OTP faults
C2	ISET	Current Limit Setting – Adjust the current limit using a resistor from ISET to GND.
C3	EN	Enable Logic Input – active-high with internal 1M Ω pull down

1. SW = Device ID, XX = Date Code, YY = Assembly Code and ZZZZ = Serial Number.

Absolute Maximum Ratings²

Symbol	Description	Value	Units
V _{OUT}	OUT to GND (continuous)	-0.3 to 29	V
	OUT to GND (during IEC61000-4-5 surge event with external TVS)	-5 to 35	V
V _{IN}	IN to GND	-0.3 to 6.0	V
V _{ISET} , V _{IO}	ISET, EN, FLT to GND	-0.3 to 6.0	V
I _{SW}	Maximum Continuous Switch Current	3.7	A
T _J	Operating Temperature Range	-40 to 150	°C
T _S	Storage Temperature Range	-55 to 150	°C
T _{LEAD}	Maximum Soldering Temperature (at leads, 10 sec)	260	°C

ESD and Surge Ratings³

Symbol	Description	Value	Units
V _{ESD_HBM}	JEDEC JS-001-2017 Human Body Model (all pins)	±2	kV
V _{ESD_CD}	IEC61000-4-2 Contact Discharge (OUT) ⁴ (When bypassed to GND with minimum 1.0μF capacitor)	8	kV
V _{ESD_AGD}	IEC61000-4-2 Air Gap Discharge (OUT) ⁴ (When bypassed to GND with minimum 1.0μF capacitor)	15	kV

Thermal Capabilities⁵

Symbol	Description	Value	Units
Θ _{JA}	Thermal Resistance – Junction to Ambient	99	°C/W
P _D	Maximum Power Dissipation at T _A = 25°C (T _J = 125°C)	1.01	W
ΔP _D /ΔT	Derating Factor Above T _A = 25°C	10.1	mW/°C

- Stresses above those listed in Absolute Maximum Ratings may cause permanent damage to the device. Functional operation at conditions other than the operating conditions specified is not implied. Only one Absolute Maximum rating should be applied at any one time.
- ESD Ratings conform to JEDEC and IEC industry standards. Some pins may performance better than specified.
- Guaranteed by design only.
- Junction to Ambient thermal resistance is highly dependent on PCB layout. Values are based on thermal properties of the device when soldered to an EV board.

Recommended Operating Conditions⁶

Symbol	Description	Value	Units
V _{OUT}	Output Voltage Range	0 to 29	V
V _{IN}	Input Supply Voltage	2.5 to 5.5	V
C _{OUT}	Output Capacitance	1 to 100	μF
R _{ISET}	Current Limit Setting Resistance	315 to 2100	Ω
T _A	Ambient Operating Temperature	-40 to 85	°C

Electrical Characteristics⁷

Unless otherwise noted, the *Min* and *Max* specs are applied over the full operation temperature range of -40°C to +85°C and V_{IN} = 2.5V to 5.5V. Typical values are specified at T_A = +25°C and V_{IN} = 5.0V.

Supply Specifications (IN)

Symbol	Description	Conditions	Min	Typ	Max	Units
V _{IN}	Input Supply Voltage Operating Range		2.5		5.5	V
V _{UVLO}	Under-Voltage Lockout	V _{IN} rising threshold	2.15	2.3	2.45	V
		Hysteresis		100		mV
I _Q	No-Load Supply Current	Enabled, EN = 1		260	370	μA
I _{SHDN}	Shutdown Supply Current	Disabled, EN = 0		0.7	5	μA

Switch Specifications (IN, OUT)

Symbol	Description	Conditions	Min	Typ	Max	Units
R _{ON}	On-Resistance (IN to OUT) ⁸	V _{IN} = 5V, T _A = 25°C		53	65	mΩ
		V _{IN} = 3.7V, T _A = 25°C		58	72	
I _{LK(OFF)}	Off-Leakage Current	V _{IN} = 5V, V _{OUT} = 0V, EN = 0		0.7	1.5	μA
		V _{OUT} = 5V/20V, V _{IN} = 0V, EN = 0		0.1	1.0	

Thermal Shutdown Specifications

Symbol	Description	Conditions	Min	Typ	Max	Units
T _{J_SHDN}	IC Junction Thermal Shutdown	T _J rising threshold		150		°C
		Hysteresis		20		

(continued next page)

- The Recommended Operating Conditions table defines the conditions for actual device operation and are specified to ensure optimal performance to the datasheet specifications. Kinetic does not recommend exceeding them or designing to the Abs. Max. Ratings.
- Device is guaranteed to meet performance specifications over the -40°C to +85°C operating temperature range by design, characterization and correlation with statistical process controls.
- Tested in test mode with RCP disabled, using ≤ 1A output current, at room temperature.

Electrical Characteristics (continued)⁹

Unless otherwise noted, the *Min* and *Max* specs are applied over the full operation temperature range of -40°C to +85°C and $V_{IN} = 2.5V$ to $5.5V$. Typical values are specified at $T_A = +25^\circ C$ and $V_{IN} = 5.0V$.

Over-Temperature Protection Specifications

Symbol	Description	Conditions	Min	Typ	Max	Units
t_R	Soft-Start Output Rising Slew-Rate Ramp Time ¹⁰	$R_L = 100\Omega, C_{OUT} = 10\mu F$		0.6		ms
I_{CLP_SS}	Soft-Start Current Limit			650		mA
t_{LIM_SS}	Soft-Start Current Limit Done Time ¹¹			7.3		ms

Over Current Protection (OCP) Specifications

Symbol	Description	Conditions	Min	Typ	Max	Units
I_{OCP}	Over-Current Protection (OCP) Threshold			6.5		A
t_{OCP}	OCP Response Time ¹²			100		ns
t_{OCP_REC}	OCP Recovery Time			t_R		ms

Short Circuit Protection (SCP) Specifications

Symbol	Description	Conditions	Min	Typ	Max	Units
V_{SCP}	Short-Circuit Protection ¹³	V_{OUT} rising during t_R		$0.1 * V_{IN}$		V
		V_{OUT} after t_R		$0.4 * V_{IN}$		
t_{SCP_REC}	SCP Recovery Time			$t_{HICCUP} + t_R$		ms

Reverse Current Protection (RCP) Specifications

Symbol	Description	Conditions	Min	Typ	Max	Units
V_{RCP}	RCP Droop Regulation Voltage	$V_{RCP} = V_{IN} - V_{OUT}, I_{OUT} = 100mA$		20		mV
t_{RCP_REC}	RCP Recovery Time	$V_{OUT} < V_{IN} - 20mV$		15	50	μs
$I_{LK(RCP)}$	RCP Bias Current (OUT to GND)	$V_{OUT} = 20V, V_{IN} = 5V, EN = 1$		160		μA

Current Limit Protection (CLP) Specifications

Symbol	Description	Conditions	Min	Typ	Max	Units	
I_{CLP}	Current Limit Protection	$V_{IN} = 5.0V$	$R_{ISET} = 2100\Omega^{14}$	450	500	550	mA
			$R_{ISET} = 1050\Omega$	900	1000	1100	
			$R_{ISET} = 635\Omega^{14}$	1505	1650	1780	
			$R_{ISET} = 420\Omega^{14}$	2200	2500	2800	
			$R_{ISET} = 350\Omega$	2700	3000	3300	
			$R_{ISET} = 315\Omega^{14}$	3000	3330	3660	

9. Device is guaranteed to meet performance specifications over the -40°C to +85°C operating temperature range by design, characterization, and correlation with statistical process controls.

10. t_R is time from $V_{OUT} = 10% * V_{IN}$ until $V_{OUT} = 90% * V_{IN}$.

11. If $V_{OUT} < 40% * V_{IN}$ at end of Soft-Start Current Limit Done Time, switch turns off.

12. t_{OCP} is time from $I_{OUT} \gg 6.5A$ until switch turns off.

13. If $V_{BUS} < V_{SCP}$ during soft-start, switch turns off.

14. Guaranteed by design, characterization and statistical process control methods; not production tested.

Electrical Characteristics (continued)¹⁵

Unless otherwise noted, the *Min* and *Max* specs are applied over the full operation temperature range of -40°C to +85°C and $V_{IN} = 2.5V$ to $5.5V$. Typical values are specified at $T_A = +25^\circ C$ and $V_{IN} = 5.0V$.

Timing Specifications

Symbol	Description	Conditions	Min	Typ	Max	Units
t_{DON}	Turn-On Delay	$R_L = 100\Omega, C_{OUT} = 10\mu F$		0.6		ms
t_{DOFF}	Turn-Off Delay	$R_L = 100\Omega, C_{OUT} = 10\mu F$		0.1		ms
t_F	V_{OUT} Fall Time (strictly R_L & C_{OUT} dependent)			2.2		ms
$t_{D\overline{FLT}}$	\overline{FLT} Flag Trigger Delay Time	CLP event to $\overline{FLT} = 0$		8		ms
t_{HICCUP}	Fault Recovery Hiccup Retry Time			64		ms

Logic Pin Specifications (EN, \overline{FLT})

Symbol	Description	Conditions	Min	Typ	Max	Units
V_{IH}	Input Logic High Voltage	EN pin	0.9			V
V_{IL}	Input Logic Low Voltage	EN pin			0.25	V
R_{I_PD}	Input Logic Pull-Down	EN pin	0.72	1		M Ω
V_{OL}	Output Logic Low	\overline{FLT} pin, $I_{O_SINK} = 4mA$		0.1	0.3	V
I_{O_LK}	Output Logic Leakage	\overline{FLT} pin, $T_A = 25^\circ C, V_O = V_{IN}$		0.01	1	μA

15. Device is guaranteed to meet performance specifications over the -40°C to +85°C operating temperature range by design, characterization and correlation with statistical process controls.

Timing Diagrams

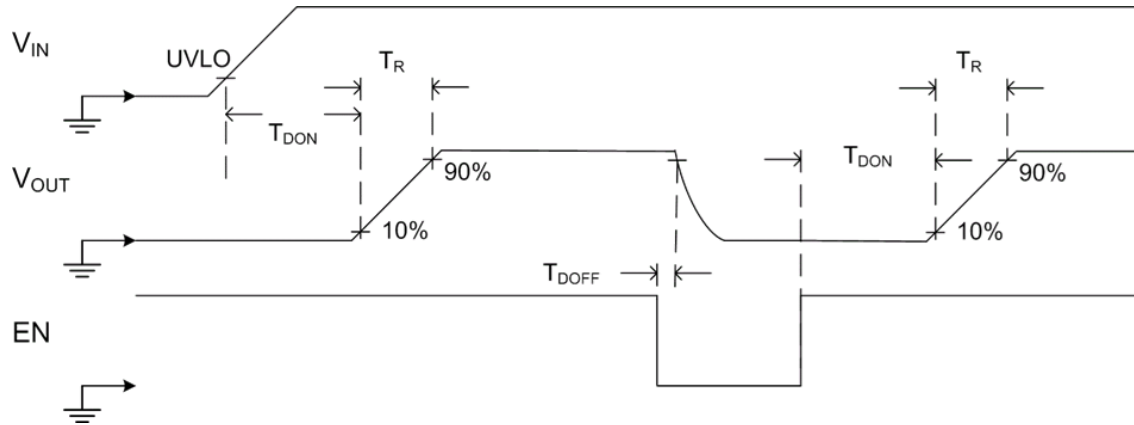

Figure 1. UVLO and EN Toggling Turn On and Off

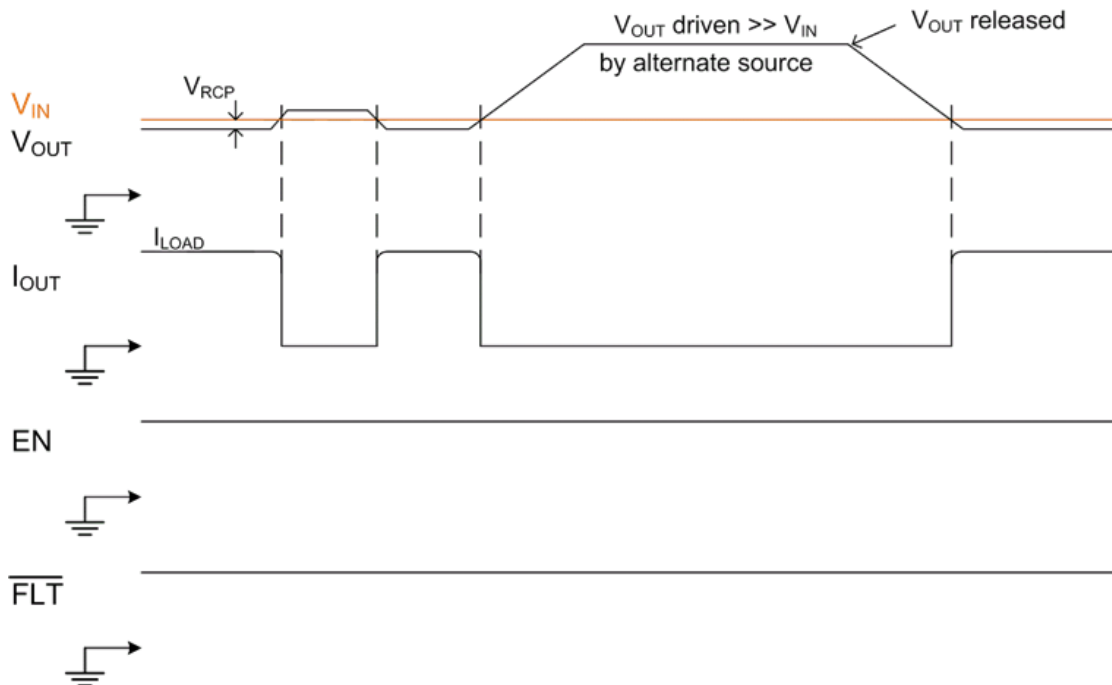

Figure 2. Reverse Current Protection (RCP)

Timing Diagrams (continued)

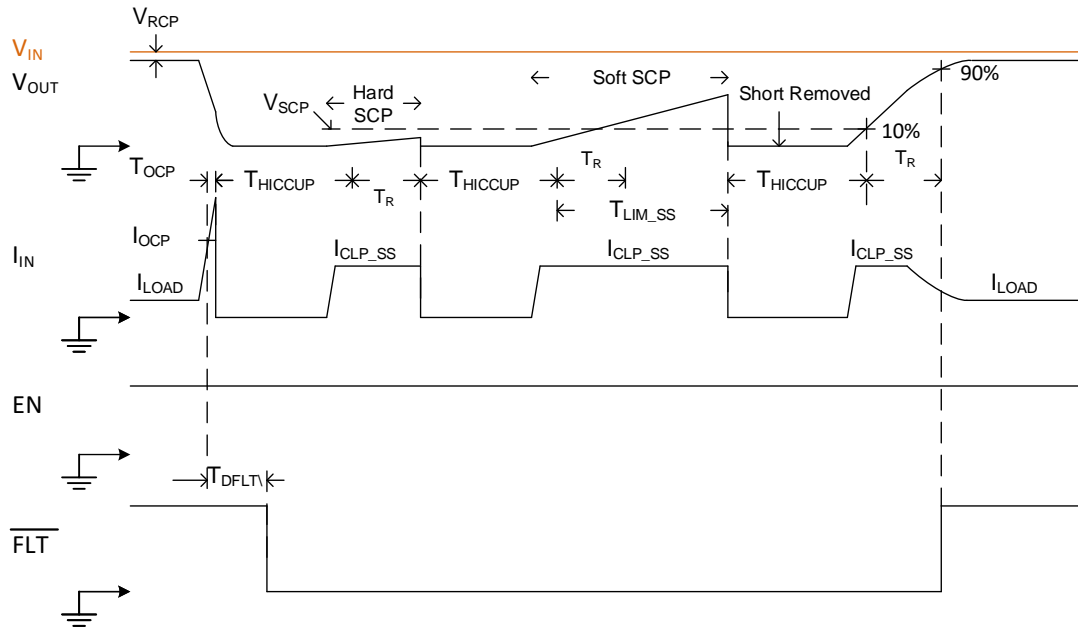

Figure 3. OCP, SS and SCP Timing Diagram

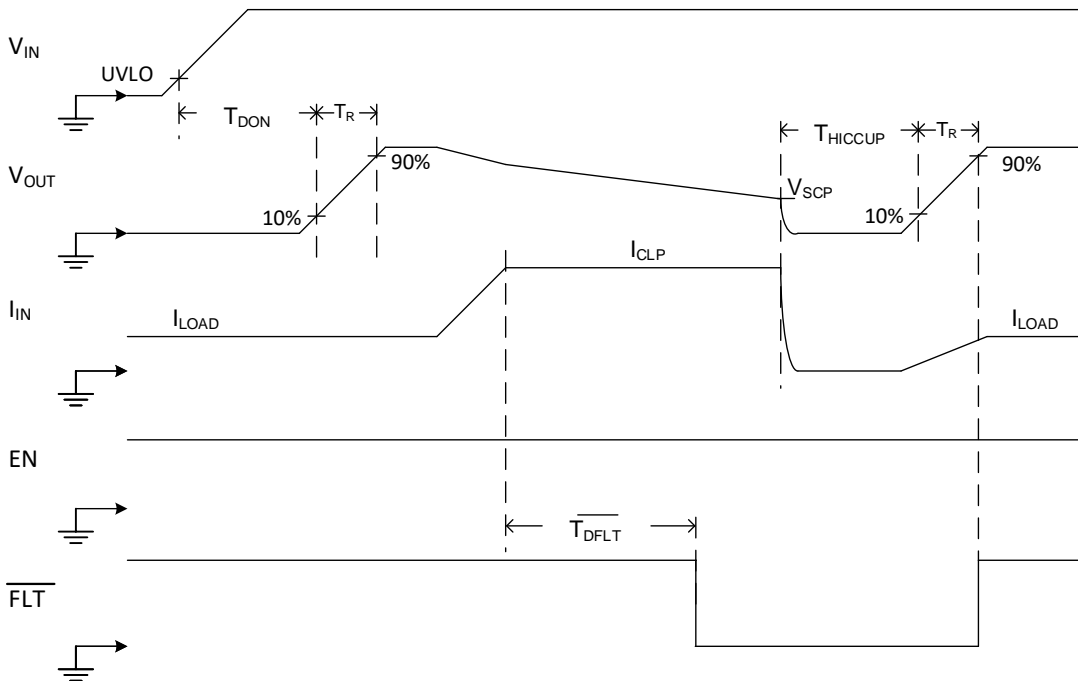
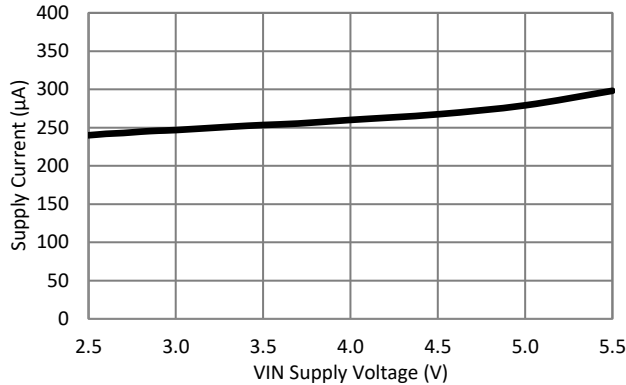

Figure 4. CLP Timing Diagram

Typical Characteristics

$V_{IN} = 5V$, $V_{EN} = V_{IN}$, $C_{IN} = 10\mu F$, $C_{OUT} = 10\mu F$, $R_{ISET} = 345\Omega$ unless otherwise noted.

No-Load Supply Current vs. VIN Voltage
(EN = High)



Shutdown Supply Current vs. VIN Voltage
(EN = Low)

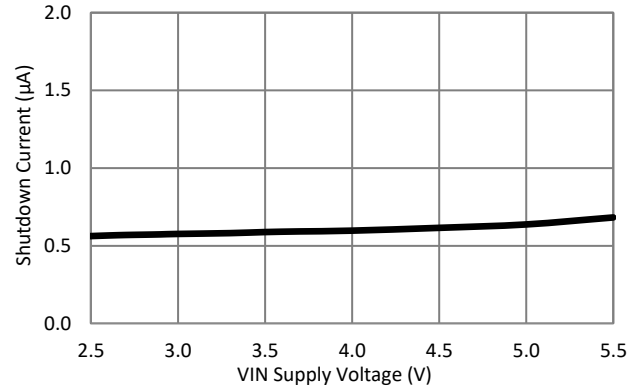

EN Logic Threshold vs. VIN

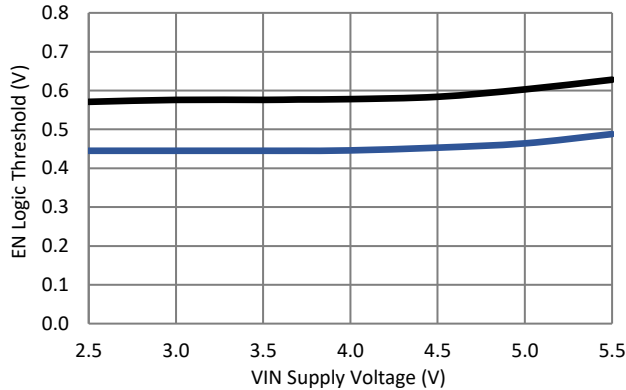

Switch On-Resistance vs. VIN

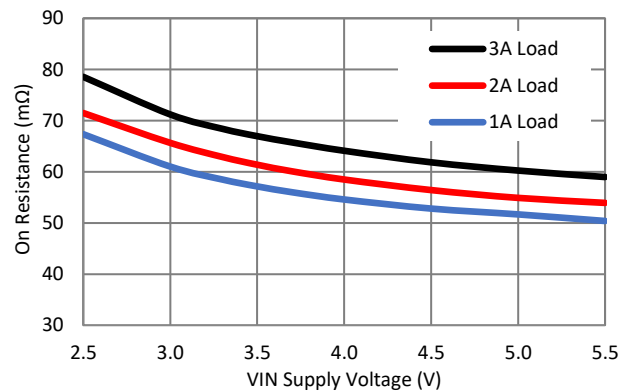

On-Resistance vs. Load Current
(VIN = 5V)

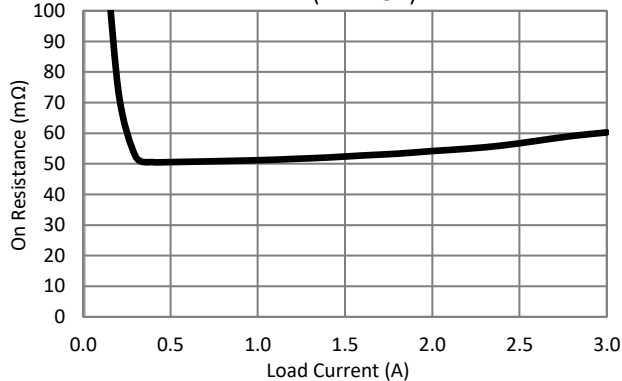

"Ideal diode" Vdroop vs. Load Current

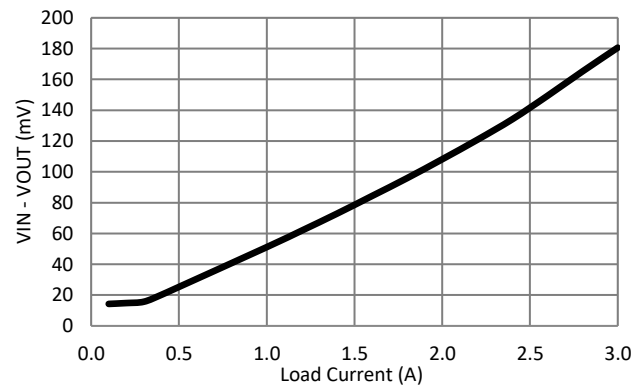

(continued next page)

Typical Characteristics

$V_{IN} = 5V$, $V_{EN} = V_{IN}$, $C_{IN} = 10\mu F$, $C_{OUT} = 10\mu F$, $R_{ISET} = 345\Omega$ unless otherwise noted.

Enable Turn-on, Turn-off Response
($R_{load} = 10\Omega$)

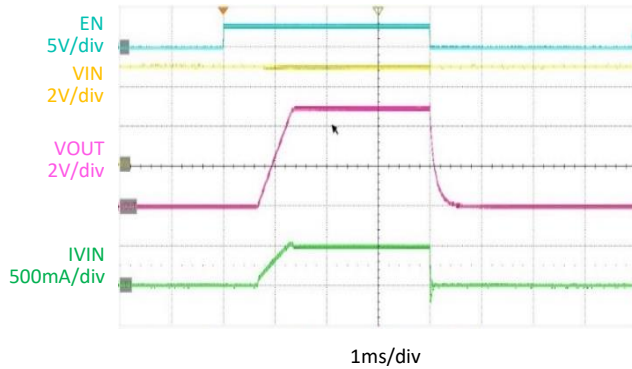

Short Circuit Protection (SCP) Response with Hiccup-Retry

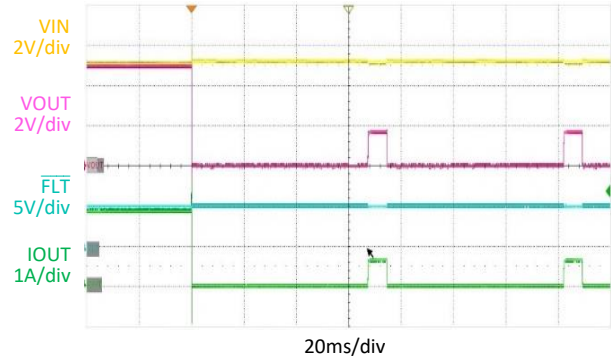

CLP Response with pulse < 8ms
(1A Current Limit)

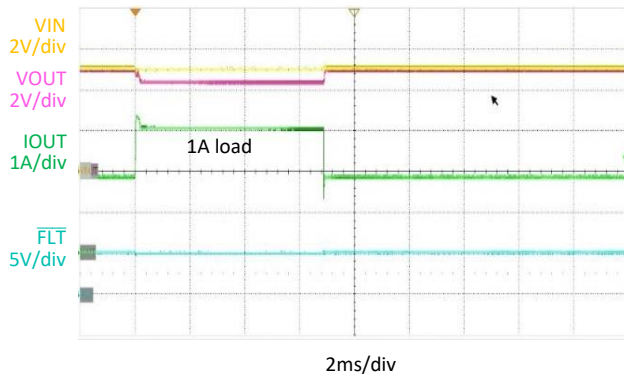

CLP Response with pulse > 8ms
(1A Current Limit)

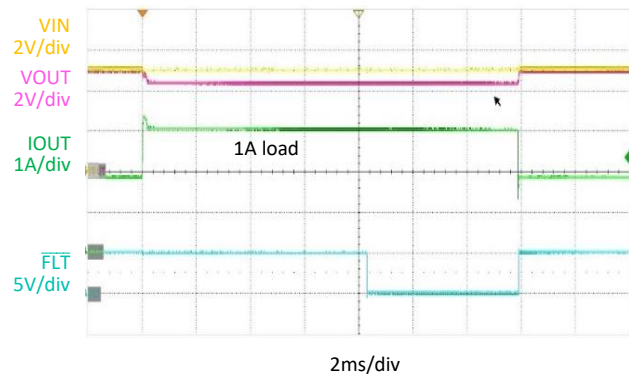

Reverse Current Protection (RCP) Response

$V_{IN} = 5V$, Load = 10Ω , then V_{OUT} Connected to 9V Supply

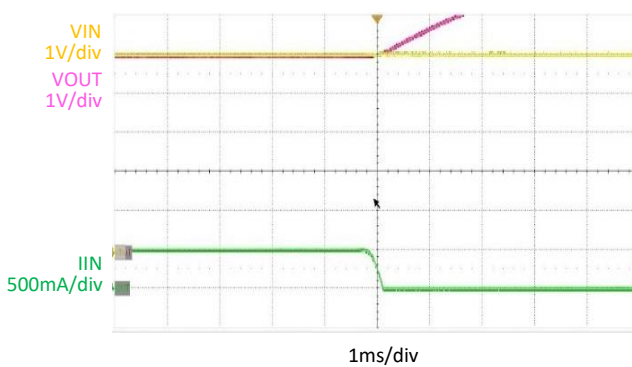

RCP Fast Recovery

$V_{OUT} = 9V$ then Disconnected with $V_{IN} = 5V$, Load = 50Ω

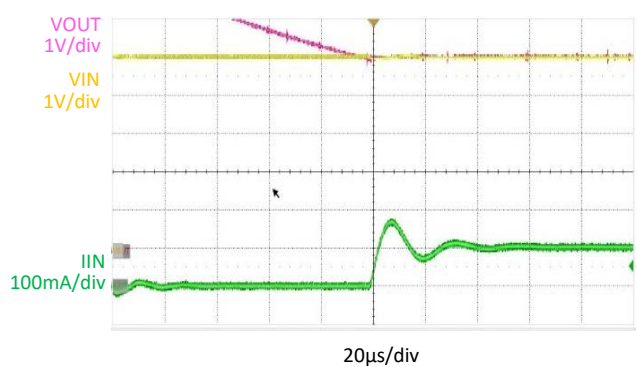

Functional Block Diagram

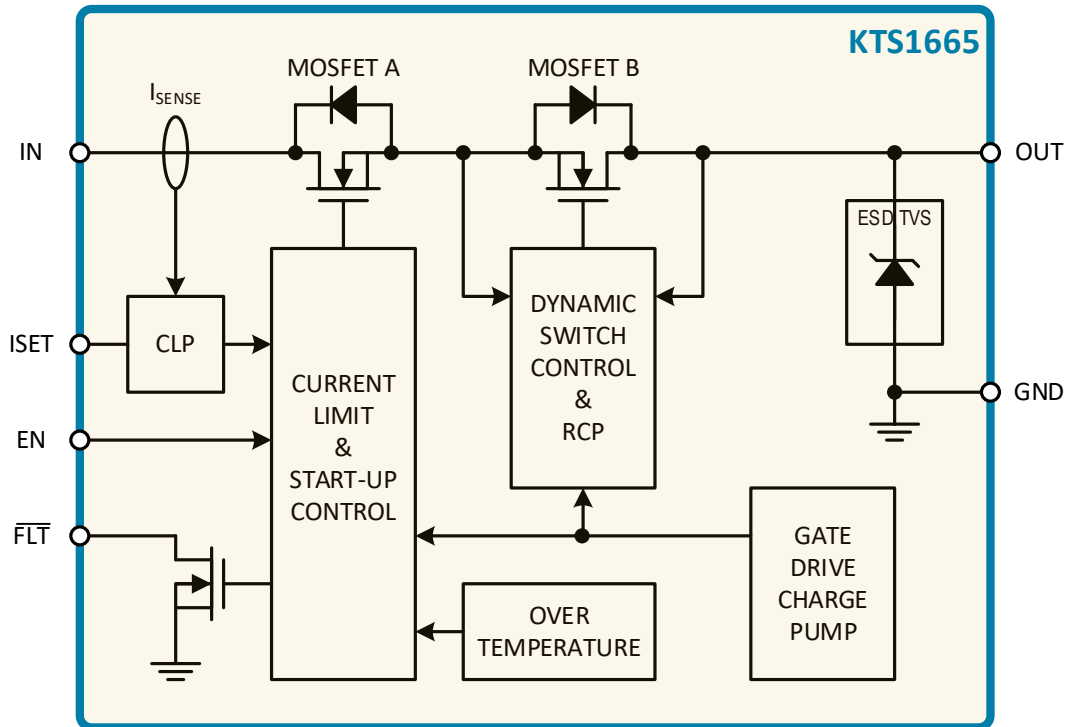

Figure 5. Functional Block Diagram

Functional Description

The KTS1665 is a 53mΩ (typ) low resistance power switch intended to be inserted between a power source and a load to isolate and protect against excessive voltage and load-current conditions at the output. It features slew-rate controlled turn ON (soft-start) to prevent input voltage droop resulting from a large inrush current when starting into capacitive loads. The KTS1665 also features several additional protection functions, such as output current limit protection, output short-circuit protection, input under-voltage lockout, reverse current protection, and over-temperature protection. KTS1665 operates over a wide input voltage range of 2.5V to 5.5V, and the output is designed to withstand up to 29V continuously (whether in shutdown or enabled).

Shutdown and Enable

When EN is set to logic 0, the main power MOSFETs are disabled, and the device enters low-power shutdown mode. When EN is set logic 1, all additional protection circuits are enabled, and if no fault condition exists, the main power MOSFETs are turned ON.

Under-Voltage Lockout (UVLO)

The UVLO function keeps the switches in the OFF state when the input voltage is below the UVLO threshold, regardless of the EN logic level. When the input voltage is above the UVLO threshold and EN is set to logic 1 and there are no fault conditions, the switches are enabled to the ON state.

Slew-Rate Controlled Turn ON (Soft-Start)

The KTS1665 has slew-rate control during normal startup for suppressing inrush current. The VOUT turn-on delay is 0.6ms (typ), and then the VOUT rise time is 0.6ms (typ) for a total start-up time of 1.2ms (typ).

Dynamic Switch Control

When the switch is turned ON, the KTS1665 dynamically adjusts MOSFET B's gate drive voltage to regulate the voltage droop from IN to OUT to 20mV. At light loads, the gate drive is reduced to maintain the 20mV from IN to OUT. The 20mV droop-regulation inherently provides automatic entry and exit from the reverse current protection mode.

Dropout

During heavy load conditions, the RON of the switches may cause more than 20mV droop, but the Dynamic Switch Control then drives the gate until the switch is fully turned ON to keep the dropout as low as possible. Dropout typically occurs when the load is greater than $20\text{mV}/53\text{m}\Omega = 0.4\text{A}$.

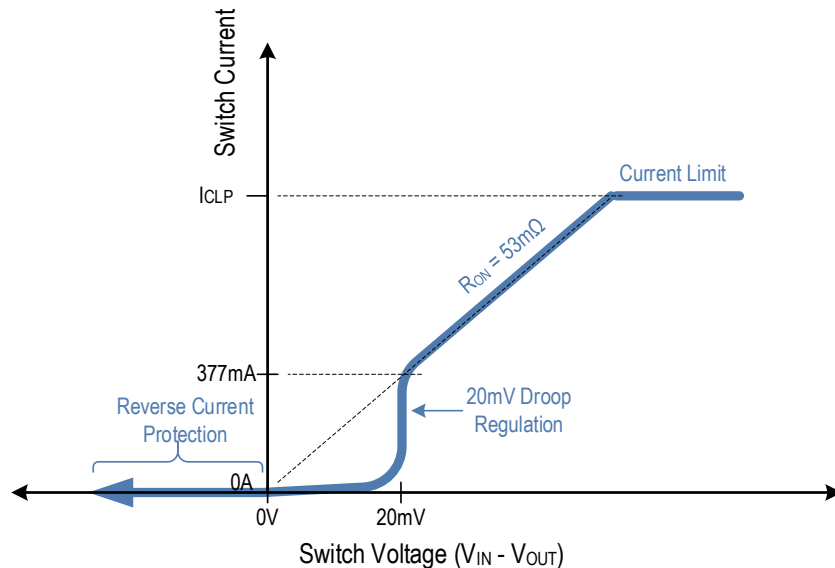

Figure 6. Switch Current vs. Switch Voltage for Dynamic Switch Control, Dropout, CLP, and RCP

Current Limit Protection (CLP)

The KTS1665 current limit is set by an external resistor, R_{ISET} , connected between the ISET and GND pins. Below equation shows the relationship between R_{ISET} and I_{CL} :

$$R_{ISET} = 1050 / I_{CL} \text{ (k}\Omega\text{)}$$

Whenever the switch current reaches the programmed current limit, the current limit regulation loop takes control and reduces the gate drive to limit the switch current. During CLP, the switch acts as a constant current source, and the output voltage reduces depending on the load current. Once the load current reduces below the current limit, the output voltage rises again until the Dynamic Switch Control takes over again. During CLP events, power dissipation increases, causing the die to heat up and possibly enter thermal shutdown. When the chip temperature cools, the device recovers and turns back ON.

Over-Current Protection (OCP)

During a sudden output short-circuit to ground event, switch current may ramp up very quickly, faster than the bandwidth of the CLP regulation loop. For this reason, the KTS1665 includes an additional over-current protection circuit (OCP). If switch current exceeds 6.5A, OCP turns OFF the switch very quickly with 100ns (typ) response time. Once off, the switch is turned back ON, but pre-biased to the current limit protection (CLP) mode.

Short-Circuit Protection (SCP)

The OCP function provides protection for short-circuit events that occur while the switch is already enabled. But for starting into a pre-existing short at the output, the KTS1665 includes additional short-circuit protection (SCP) circuitry. During normal turn-on, the current limit is held to 600mA for 7.3ms. Additionally, if the V_{OUT} fails to rise above 40% of V_{IN}, the switch is turned off, but automatically retries after the 64ms hiccup time.

CLP and SCP Use Cases

There are four use-cases for current limiting:

1. Turn ON into large capacitive load – during normal soft-start with very large capacitive loads, the slew-rate control may not be enough to prevent the switch current from reaching its programmed current limit. In this case, the output voltage does rise, but the 600mA soft-start current limit may extend the V_{OUT} rise time. Usually, the extended rise-time is too short to trigger thermal shutdown.
2. Turn ON into an output short-circuit to ground fault – if the output is already shorted to ground prior to start up, then V_{OUT} does not rise when EN is set to logic 1. In this case, the switch current is limited to 600mA, and the IC dissipates significant power, $P_D = V_{IN} \times I_{CLP_SS}$, making thermal shutdown more likely. After 7.3ms, if thermal shutdown has not occurred, and V_{OUT} remains below 0.4V_{IN}, the SCP detection turns off the switch. After a 64ms hiccup time to allow the IC to cool, the soft-start retries.
3. OUT over-current event while already enabled – if the load current exceeds the current limit while the switch is already ON, then the switch current is limited to the programmed CLP current level and the output voltage sags. As V_{OUT} sags, most loads typically reduce their current requirements, so V_{OUT} usually settles at an intermediate voltage without complete collapse. The power dissipation, $P_D = (V_{IN} - V_{OUT_SAG}) \times I_{CLP}$, is less than during an output short-circuit fault condition, so thermal shutdown is less likely, but still possible.
4. OUT short-circuit fault while already enabled – if the output is suddenly shorted to ground while the switch is already ON, then the switch current may rise very rapidly and temporarily exceed the programmed CLP current limit.
 - a. If the switch current reaches the OCP current threshold, the switch is turned OFF very quickly, and then restarted as in use-case 2 above.
 - b. If the switch current does not reach the SCP current threshold quickly, then the CLP control loop reduces the switch current to the programmed current level. In this case, the IC dissipates significant power, $P_D = V_{IN} \times I_{CLP}$, making thermal shutdown more likely.

Reverse Current Protection (RCP)

In situations when V_{OUT} is driven above V_{IN} (for example when USB charging with elevated voltage at VBUS), the dynamic switch control turns OFF MOSFET B automatically due to its 20mV droop regulation control loop. MOSFET B is connected with its body diode pointed in the opposite direction of the current-limiting MOSFET A. The reverse blocking MOSFET B is inherently turned OFF whenever V_{OUT} > V_{IN} - 20mV and turned ON again when V_{OUT} < V_{IN} - 20mV.

Every time the device starts up, it prechecks if V_{OUT} is higher than V_{IN} or not. If yes, MOSFET B is kept OFF, and reverse current is blocked. Then, after V_{OUT} returns below V_{IN}, MOSFET B is turned ON quickly within 50µs. The

fast recovery of MOSFET B is assisted by the internal gate-drive charge pump, which is enabled whenever EN = 1, even during RCP (when MOSFET B is OFF). Since the gate-drive voltage is already present, a fast recovery time is easily achieved as soon as VOUT falls below VIN by 20mV.

Over Temperature Protection (OTP)

The KTS1665 features thermal shutdown to prevent the device from overheating. The internal MOSFETs turn OFF when the junction temperature exceeds +150°C (typ), and $\overline{\text{FLT}}$ is asserted. The device exits thermal shutdown after the junction temperature cools by 20°C (typ) hysteresis, and $\overline{\text{FLT}}$ is de-asserted.

Fault Reporting ($\overline{\text{FLT}}$), see Table 1

In a current limit protection (CLP), over current protection (OCP), short-circuit protection (SCP), or over temperature protection (OTP) condition, the open-drain $\overline{\text{FLT}}$ pin is asserted LOW. A pull-up resistor should be connected from the $\overline{\text{FLT}}$ pin to the system I/O voltage rail. The $\overline{\text{FLT}}$ output returns to the high-Z state automatically once the fault condition is removed. The RCP circuit does not trigger a $\overline{\text{FLT}}$ indication.

For CLP events, an internal 8ms (typ) timer delays the fault indication at the $\overline{\text{FLT}}$ pin. However, for other fault events, the $\overline{\text{FLT}}$ indication asserts immediately upon thermal shutdown.

EN	VIN	$\overline{\text{FLT}}$	Event or Condition
X	< V _{UVLO}	Z	UVLO, Switch Off
L	2.5V to 5.5V	Z	Shutdown Mode, Switch Off
H	2.5V to 5.5V	Z	Device Enabled, Soft-Start Slew-Rate Enabled
H	2.5V to 5.5V	L	Device Enabled, CLP Event, Switch is Isource
H	2.5V to 5.5V	L	Device Enabled, OCP or SCP or OTP Event, Switch Open
X	2.5V to 5.5V & V _{OUT} > V _{IN}	Z	RCP Event, Switch Open

Table 1. $\overline{\text{FLT}}$ Open-Drain Output Flag Truth Table

Applications Information

C_{IN} Input Capacitor

For most applications, connect a 10 μ F or larger ceramic capacitor as close as possible to the device from IN to GND to minimize the effect of parasitic trace inductance. Select a C_{IN} with voltage rating of 6.3V or higher. In most applications, the regulated 5V source that feeds IN will have additional bulk capacitance at its output. 47 μ F or more of additional bulk capacitance is typical.

C_{OUT} Output Capacitor

The internal soft-start function allows the KTS1665 to charge an output capacitor up to 100 μ F without turning OFF due to overcurrent. Typically, USB VBUS is 10 μ F nominal at the local side, but capability to 100 μ F allows for high capacitance in a remote device connected to the USB port. As a minimum, it is recommended to bypass OUT with a 1 μ F to 10 μ F ceramic capacitor and place it as close as possible to the OUT pin.

Recommended PCB Layout

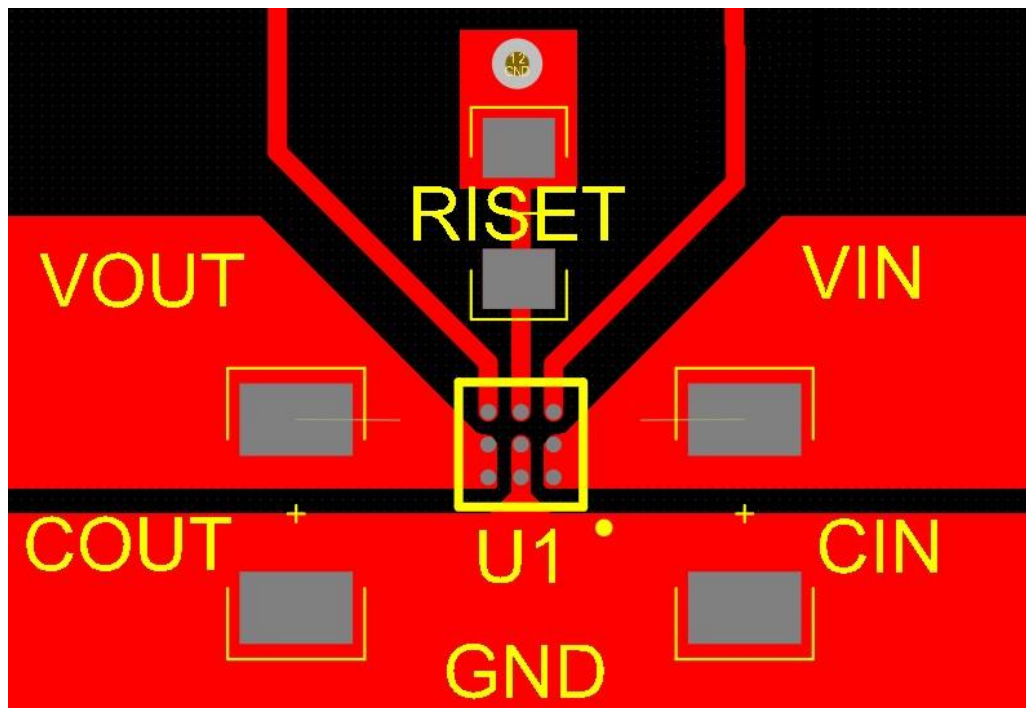
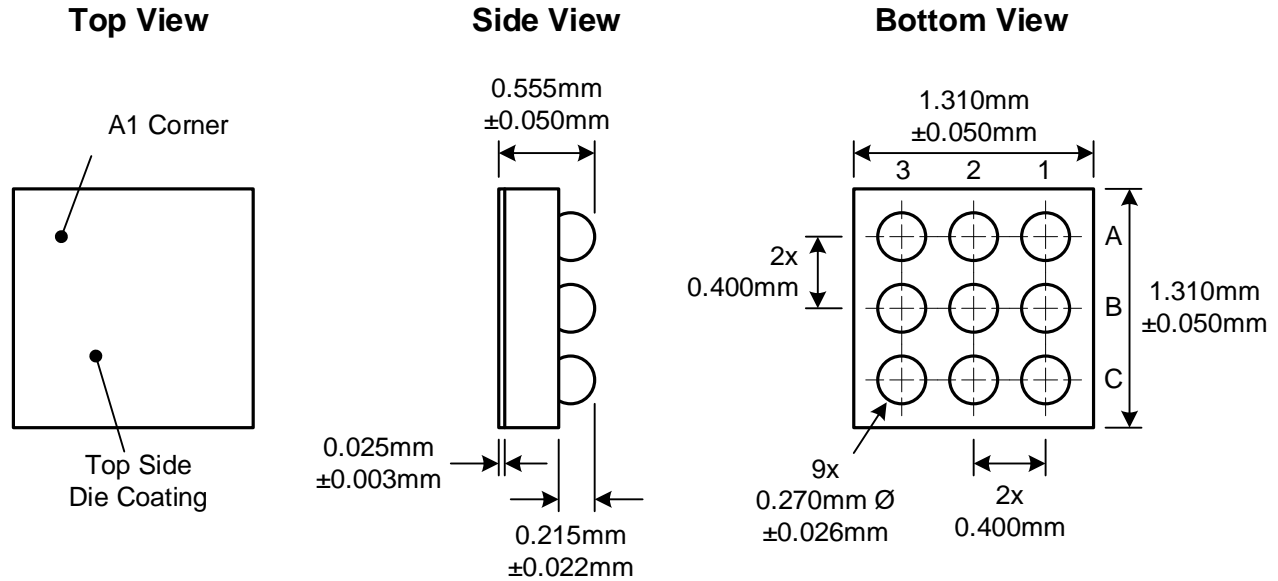

Figure 7. Recommended PCB Layout

Packaging Information

WLCSP33-9 (1.31mm x 1.31mm x 0.555mm)



Recommended Footprint

(NSMD Pad Type)

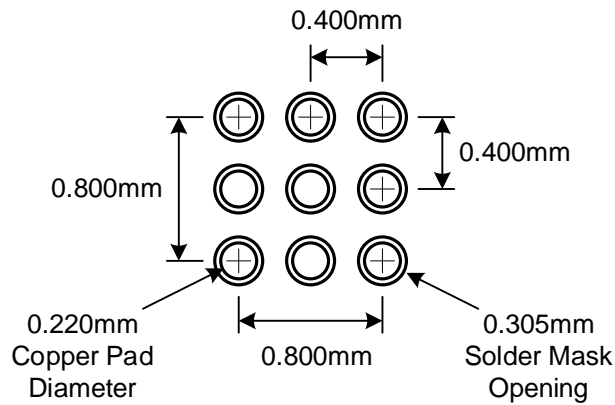

Kinetic Technologies cannot assume responsibility for use of any circuitry other than circuitry entirely embodied in a Kinetic Technologies product. No intellectual property or circuit patent licenses are implied. Kinetic Technologies reserves the right to change the circuitry and specifications without notice at any time.