

## Dual-Input Smart Push-Button Reset IC

### Features

- Operating Range: 1.6V~5.5V
- Supply Current in standby: <math>< 1\mu\text{A}</math> ( $V_{DD} = 4\text{V}$ )
- Output Delay time (RST0 & 1 input pin): 10s Typ.
- Reset Pulse Time (SRO, nSRO Output): 400ms Typ.
- ESD Protection
  - Human Body Model: 2kV
  - Charged Device Model: 1.5kV
- Over-Temperature Protection
- -40°C to +85°C Temperature Range

### Applications

- Mobile Phones & Tablets
- Wearable Devices
- Portable Instruments
- Remote Controls
- Gaming
- DSC, DVR, GPS

### Brief Description

The KTS1613 is a two input, two output Smart Push-Button Reset IC. A reset pulse is generated for a fixed discharge time (400ms typ) after both manual reset inputs have been held low for the reset request time of 10s.

The KTS1613 operates over the 1.6 V to 5.5V supply voltage range, consuming less than 10 $\mu\text{A}$  of supply current at 4V.

The KTS1613 has 2 digital output pins, nSRO and SRO. nSRO is an active-low open-drain output pin. SRO is an active-high push-pull output which can be used to control a P-channel MOSFET battery disconnect switch. It features a soft turn on and turn off feature to reduce VBAT rising and falling overshoot.

The KTS1613 is available in lead-free, fully green compliant, small 10-pin UQFN 2.0mm x 1.5mm package.

### Typical Application

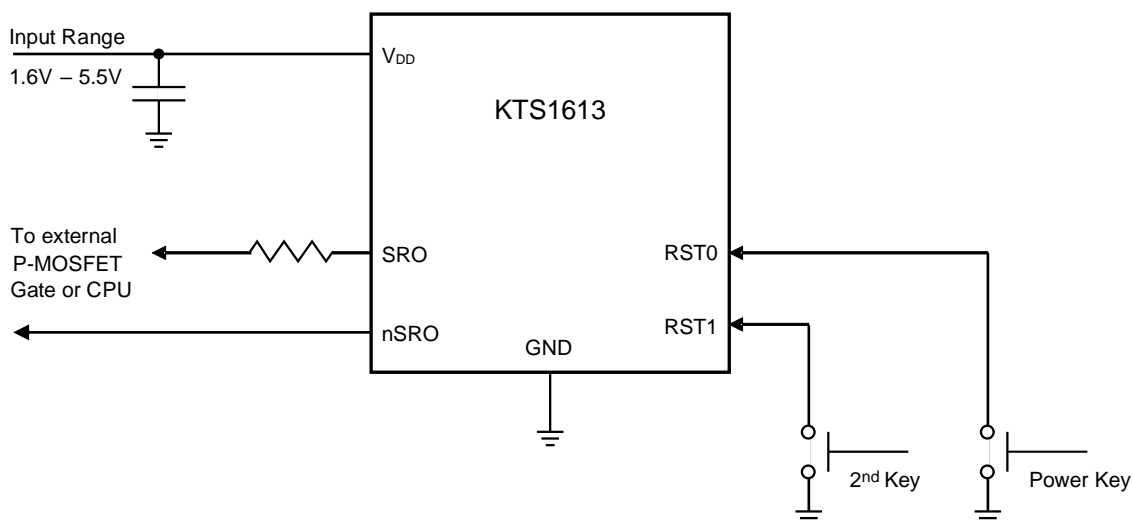

## Pin Descriptions

Pin #	Name	Function	IO Characteristics
1, 2, 3, 7, 8	GND	Ground connection.	-
4	V <sub>DD</sub>	Power supply input.	-
5	RST0	Reset signal input 0.	Internal pull down (8MΩ)
6	RST1	Reset signal input 1.	No internal pull up resistor
9	SRO	Digital output. Active HIGH (V <sub>DD</sub> )	Push-Pull
10	nSRO	Digital output, Active LOW	Open-drain

**UQFN2.0x1.5-10**  
(Top View)

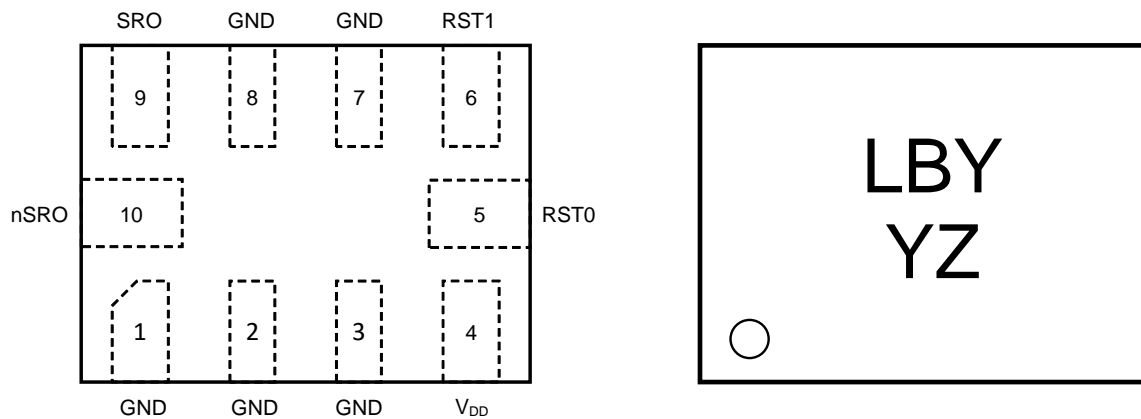

10-Lead 2.0mm x 1.50mm x 0.55mm  
UQFN Package

Top Mark

LB = Device ID Code, YY = Date Code, Z = Assembly Code

## Absolute Maximum Ratings<sup>1</sup>

(T<sub>A</sub> = 25°C unless otherwise noted)

Symbol	Description	Value	Units
V <sub>DD</sub>	Power supply input.	-0.3 to +12 (DC)	V
RST0, RST1, SRO, nSRO	Reset inputs, Digital outputs.	-0.3 to +6	V
T <sub>J</sub>	Maximum Junction Temperature Range	-40 to 150	°C
T <sub>s</sub>	Storage Temperature Range	-65 to 150	
T <sub>LEAD</sub>	Maximum Soldering Temperature (at leads, 10sec)	300	

## Thermal Capabilities<sup>2</sup>

Symbol	Description	Value	Units
θ <sub>JA</sub>	Thermal Resistance – Junction to Ambient	73	°C/W
P <sub>D</sub>	Maximum Power Dissipation at T <sub>A</sub> ≤ 25°C	1712	mW
ΔP <sub>D</sub> /°C	Derating Factor Above T <sub>A</sub> = 25°C	13.7	mW/°C

## Ordering Information

Part Number	Marking <sup>3</sup>	Operating Temperature	Package
KTS1613EQU-TR	LBYYZ	-40°C to +85°C	UQFN2.0x1.5-10

## Recommended Operating Range<sup>4</sup>

Description	Value
V <sub>DD</sub>	-0.3V to 5.5V
RST0, RST1 SRO, nSRO	-0.3V to 5V

- Stresses above those listed in Absolute Maximum Ratings may cause permanent damage to the device. Functional operation at conditions other than the operating conditions specified is not implied. Only one Absolute Maximum rating should be applied at any one time.
- Junction to Ambient thermal resistance is highly dependent on PCB layout. Values are based on thermal properties of the device when soldered to a PCB board.
- LB = Device ID Code, YY = Date Code, Z = Assembly Code.
- The device is not guaranteed to function outside of recommended operating condition.

## Electrical Characteristics<sup>5</sup>

The *Min* and *Max* specs are applied over the full operation temperature range of -40°C to +85°C,  $V_{IN} = 1.6V$  to 5.5V unless otherwise noted, while *Typ* values are specified at  $V_{DD} = 4.0V$  and room temperature ( $T_A = 25^\circ C$ ) unless otherwise noted.

Symbol	Description	Conditions	Min	Typ	Max	Units
<b>Basic Operation</b>						
$V_{DD}$	Input Voltage Range		1.6		5.5	V
$I_Q$	Quiescent supply current	Standby (Exclude pull up/down resistor, Internal oscillator is off, $V_{DD} = 4V$ )			1	$\mu A$
$I_{SS}$	Operation current	Active (Before reset signal output, Internal oscillator is on, $V_{DD} = 4V$ )			10	$\mu A$
<b>Digital IO</b>						
$V_{IL}$	Digital input logic low level	RST0, RST1 pins $V_{DD} = 2.5V$ to $4.6V$			0.4	V
$V_{IH}$	Digital input logic high level		1.0			V
$V_{OL}$	Digital output logic low level	SRO pin, $I = 1.2\mu A$ ( $V_{DD} = 4V$ )			0.3	V
$V_{OH}$	Digital output logic high level		$0.85 \cdot V_{DD}$	$V_{DD}$		V
$I_L$	RST0/RST1 input leakage current		-	-	1	$\mu A$
$V_{OL}$	Digital output logic low level	nSRO, $I_o = 2mA$			0.3	V
<b>RESET</b>						
$T_R$	Reset request time	$V_{DD} = 4V$	8.5	10	11.5	s
$T_D$	Reset pulse time			400		ms
<b>ESD PROTECTION</b>						
$V_{ESD}$	Human Body Model (HBM)	All pins		$\pm 2$		kV
	IEC61000-4-2 Contact discharge	$V_{DD}$ pin		$\pm 8$		kV
	IEC61000-4-2 Air gap discharge	$V_{DD}$ pin		$\pm 15$		kV

5. All specifications are 100% production tested at  $T_A = +25^\circ C$ , unless otherwise noted. Specifications are over -40°C to +85°C and are guaranteed by design.

## Typical Characteristics

$V_{DD} = 4V$ ,  $T_A = 25^\circ C$  unless otherwise specified.

**Quiescent Current vs. VDD**

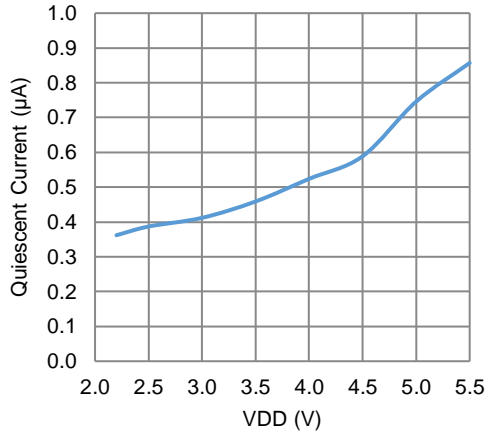

**Operation Current vs. VDD (before Reset pulse)**

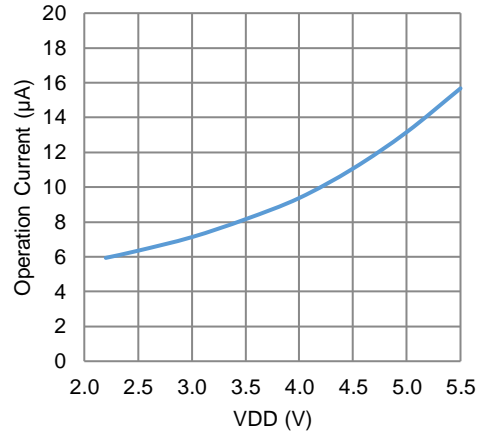

**RST0/RST1 Digital Input Logic Threshold Vs. VDD**

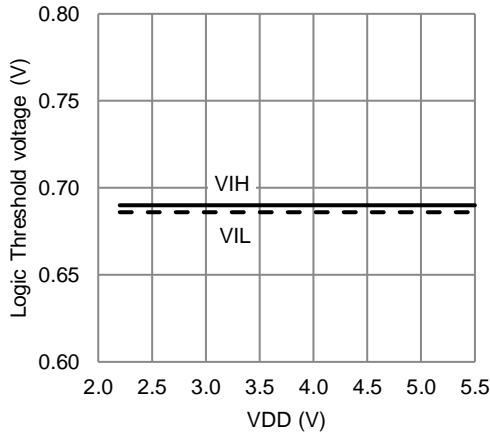

**Reset Mode Trigger**

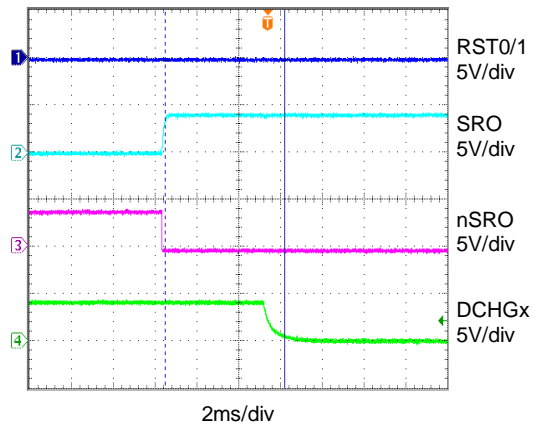

**Enter Reset Mode**

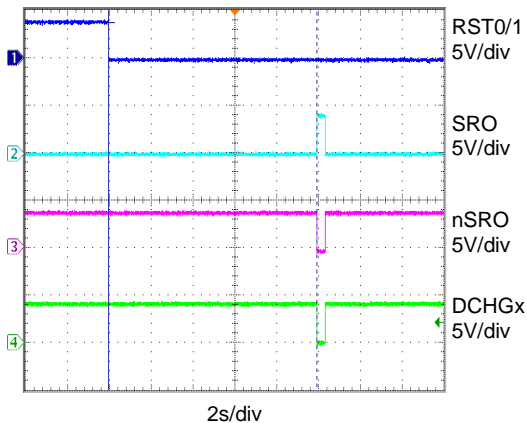

**Reset Mode Pulse**

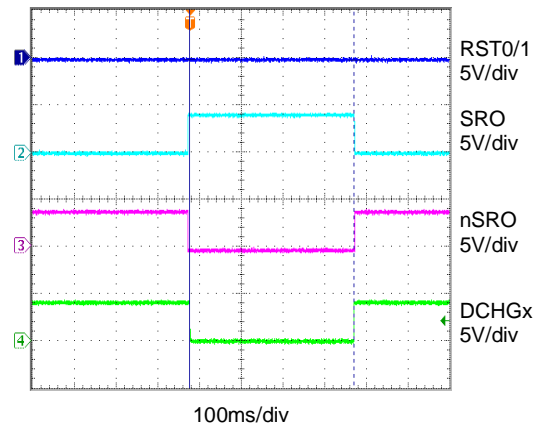

## Function Description

### Reset Timing

Reset occurs only after both RST0 and RST1 stay low for  $T_r$  duration, SRO output goes high for  $T_d = 400\text{ms}$ , then SRO output goes low.

If RST0 & RST1 stay low indefinitely, KTS1613 only resets one time.

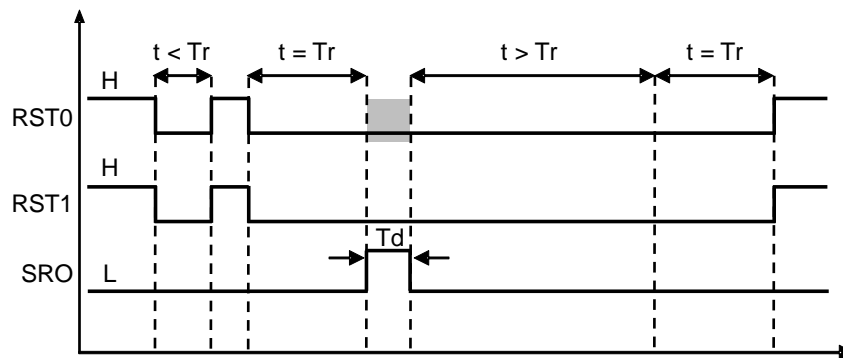

Figure 1. Reset Timing

### Soft Turn ON and OFF

SRO output has soft turn on and turn off feature in order to reduce VBAT rising and falling overshoot. The output rising and falling time equal to 2ms typical.

nSRO is an open-drain output pin, there is no soft turn on & off feature for nSRO. The timing of SRO and nSRO is shown in Figure 4.

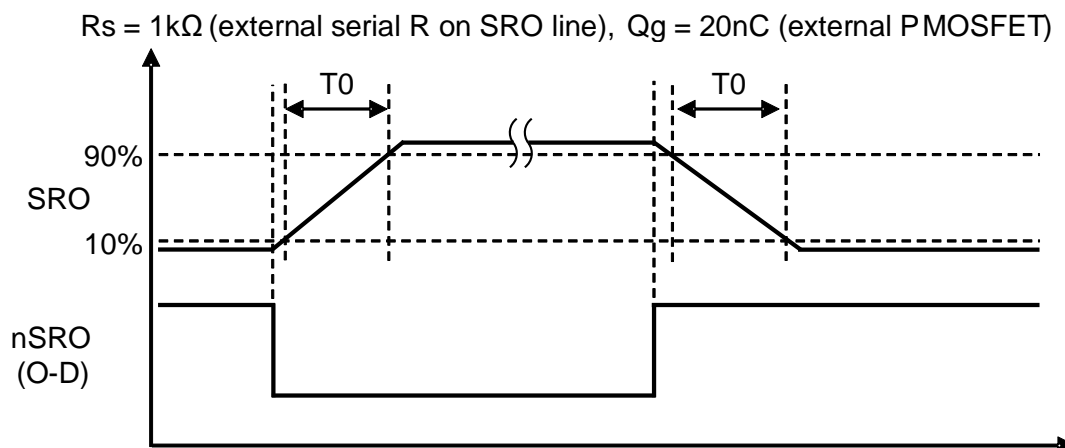
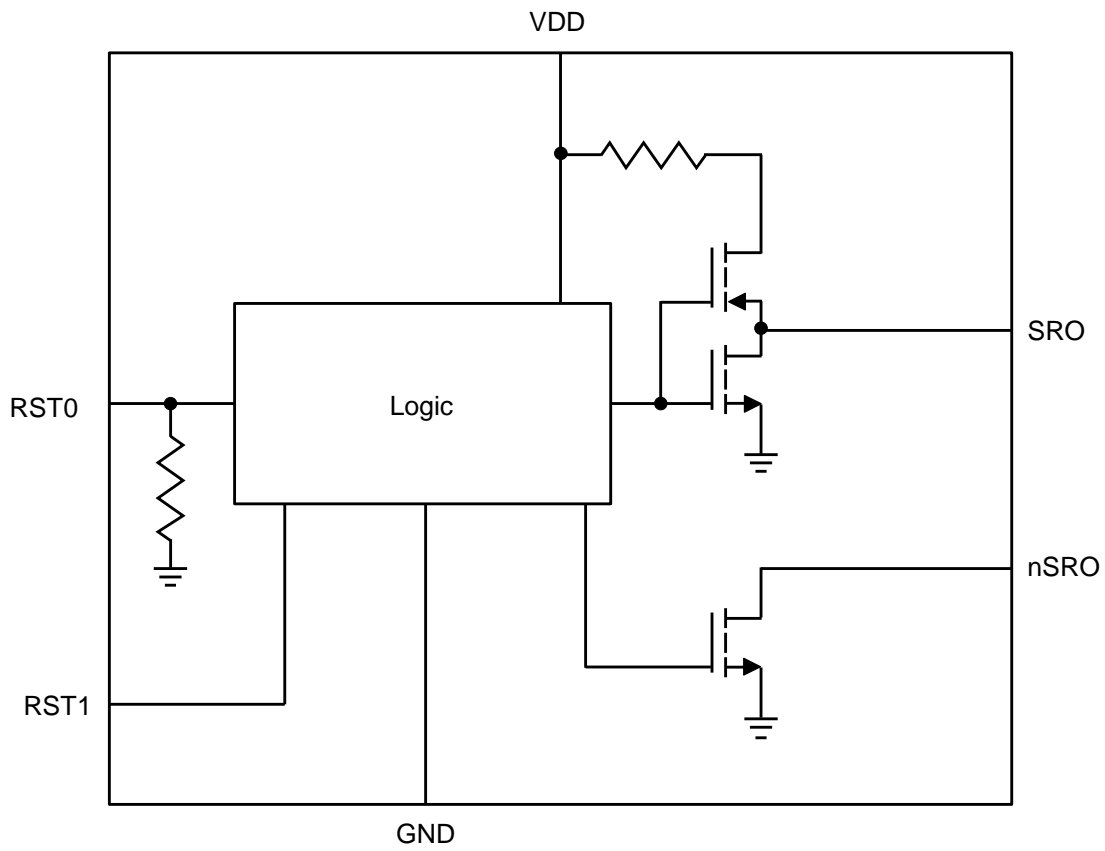

Figure 2. SRO Soft Turn ON and OFF Timing

**Functional Block Diagram**



**Figure 3. Block Diagram**

## Application Circuit

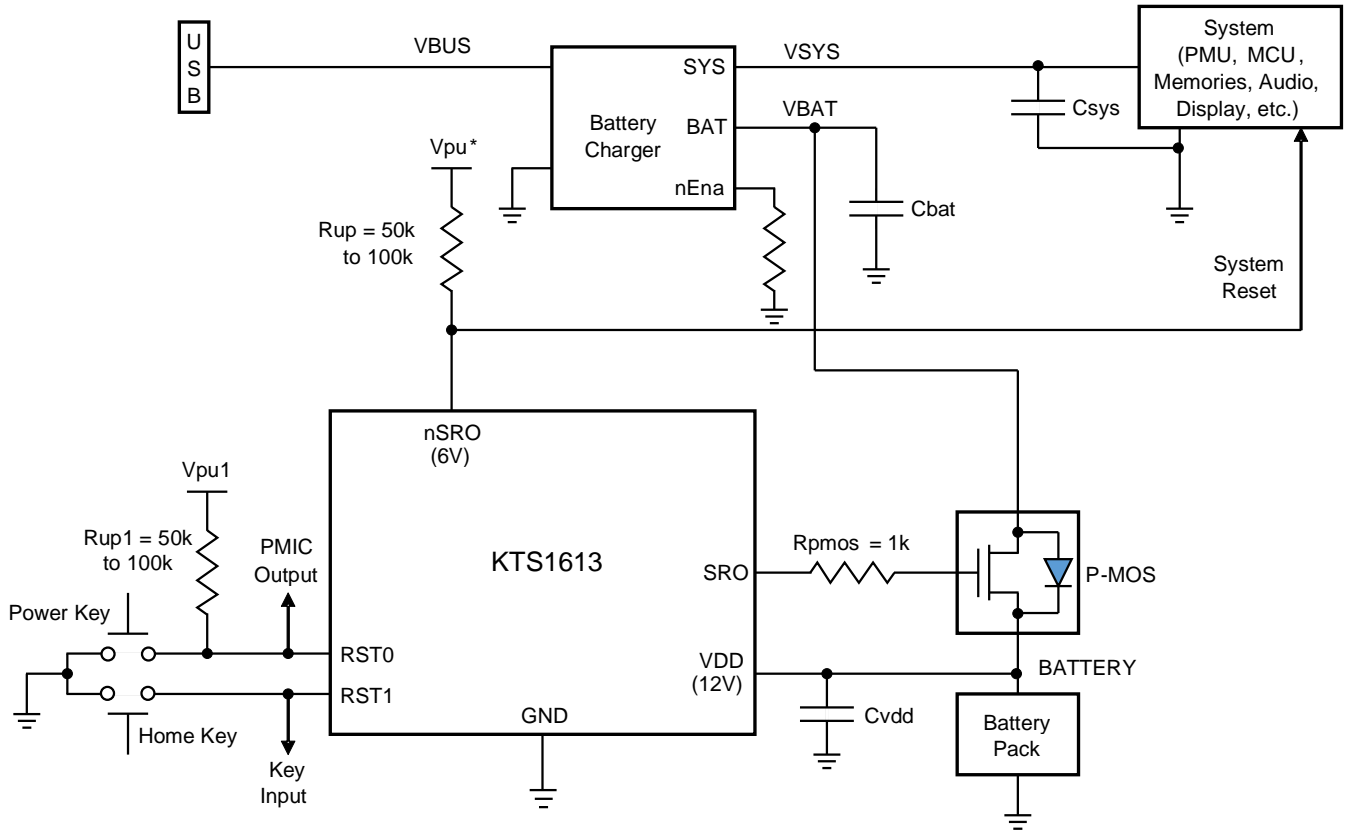
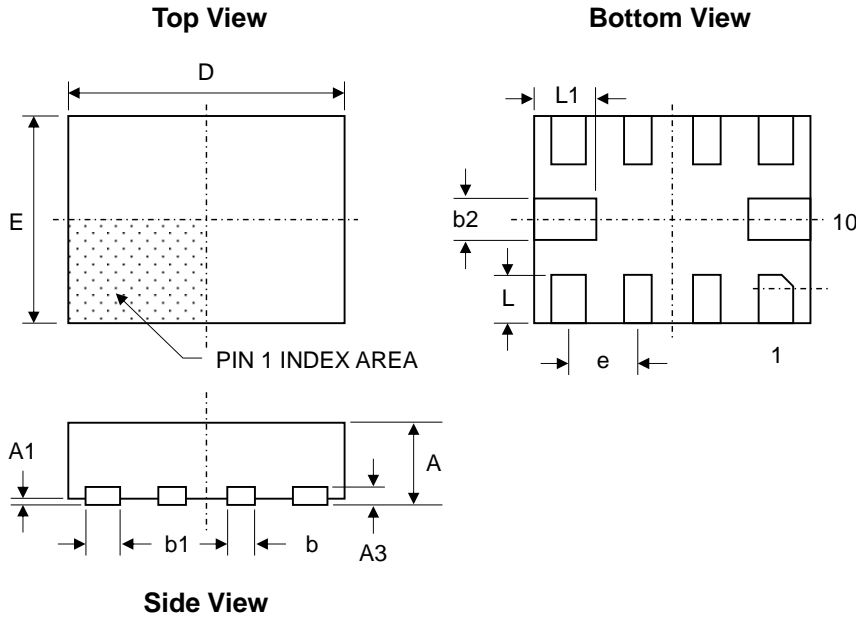

Figure 4. Application Circuit

## Packaging Information

UQFN2.0x1.5-10 (2.0mm x 1.50mm x 0.55mm)



Dimension	mm		
	Min.	Typ.	Max.
A	0.50	0.55	0.60
A1	0.00	-	0.05
A3	0.152 REF		
b	0.15	0.20	0.25
b1	0.20	0.25	0.30
b2	0.25	0.30	0.35
D	1.95	2.00	2.05
D2	-	-	-
E	1.45	1.50	1.55
E2	-	-	-
e	0.50 REF		
L	0.30	0.35	0.40
L1	0.40	0.45	0.50

## Recommended Footprint

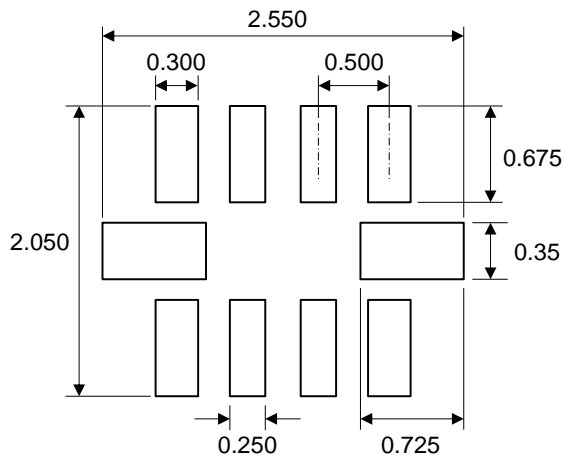

\* Dimensions are in millimeters.

Kinetic Technologies cannot assume responsibility for use of any circuitry other than circuitry entirely embodied in a Kinetic Technologies product. No intellectual property or circuit patent licenses are implied. Kinetic Technologies reserves the right to change the circuitry and specifications without notice at any time.