

CONNECTION TABLE		CONN (REF)
LEAD COLOR	SIGNAL	PIN
BLUE	CH A	1
BLUE/WHITE	CH A-	2
YELLOW	CH B	3
YELL/WHITE	CH B-	4
ORANGE	INDEX	5
ORN/WHITE	INDEX-	6
-	N/A	9
-	N/A	10
-	N/A	13
-	N/A	14
-	N/A	11
-	N/A	12
RED	+Vcc	7
BLK	GND	8
DRAIN	SHIELD	15

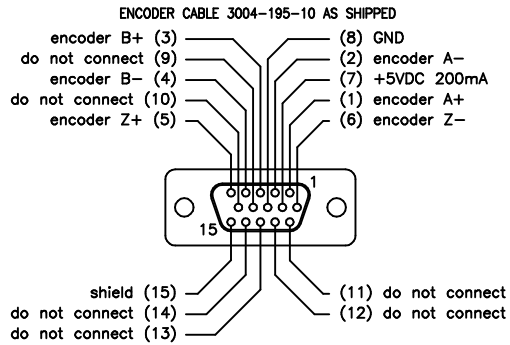

*ALL DIMENSIONS IN MM

TOLERANCES	THIRD ANGLE PROJECTION		APPLIED MOTION PRODUCTS, INC.	
DECIMALS: MM X.XX = ±0.13 X.X = ±0.25 X = ±0.5				
ANGLES: MACH. = ±0.5° CHAM. = ±5°				
COMPUTER DATA BASE DRAWING	APPROVALS	DATE	STEP MOTOR OUTLINE DWG NO. HT34-687D-YAC REV A	
	DRAWN K.KESLER	9/18/17		
	CHECKED K.KESLER	9/18/17		
	APPROVED J.KORDIK	9/18/17		