

316 STAINLESS STEEL HINGE PIN

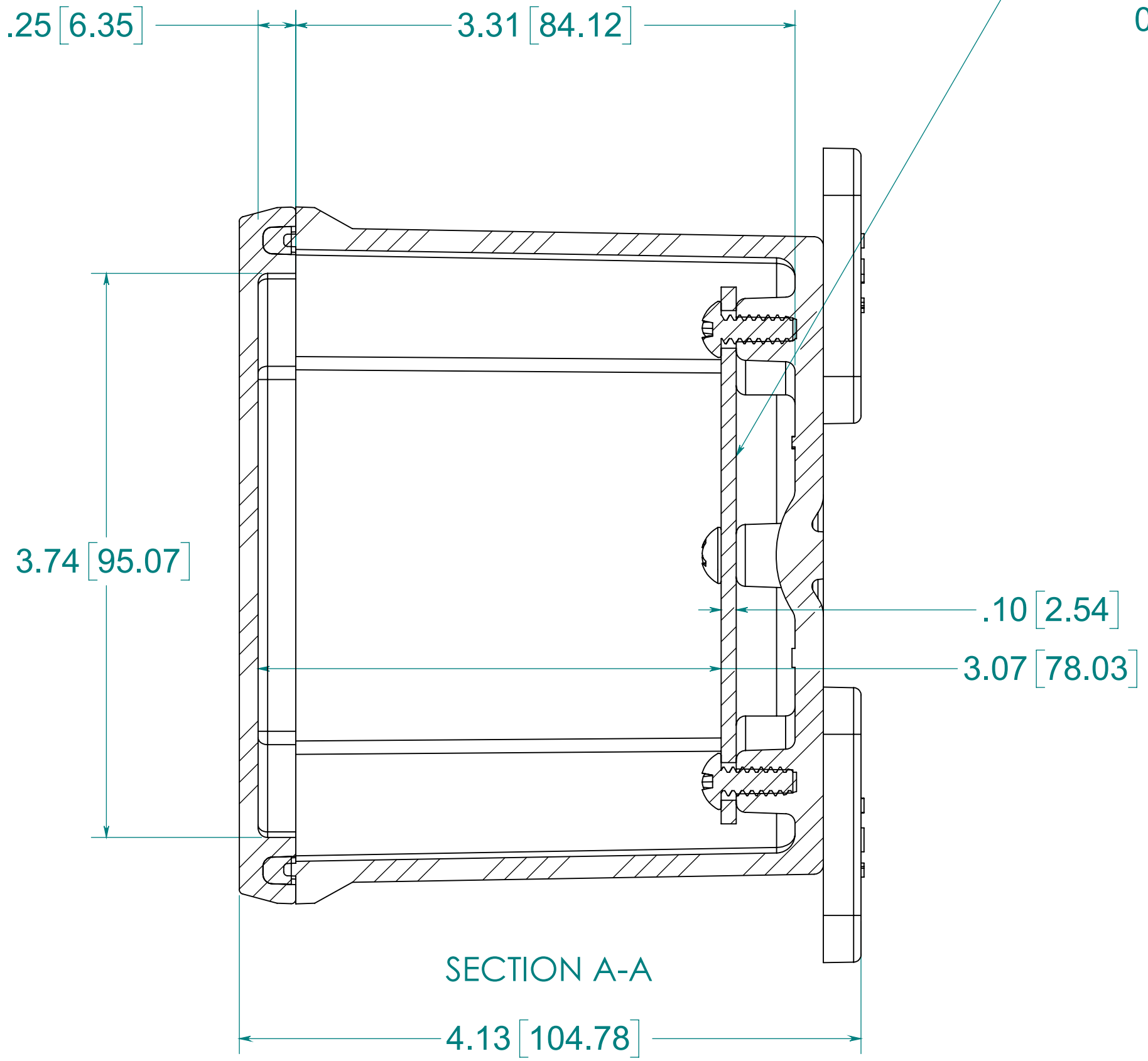

OPTIONAL BACK PANEL SHOWN
 0.100 [2.54mm] TH'K - ALUMINUM
 0.075 [1.91mm] TH'K - WHITE STEEL
 0.188 [4.78mm] TH'K - PVC

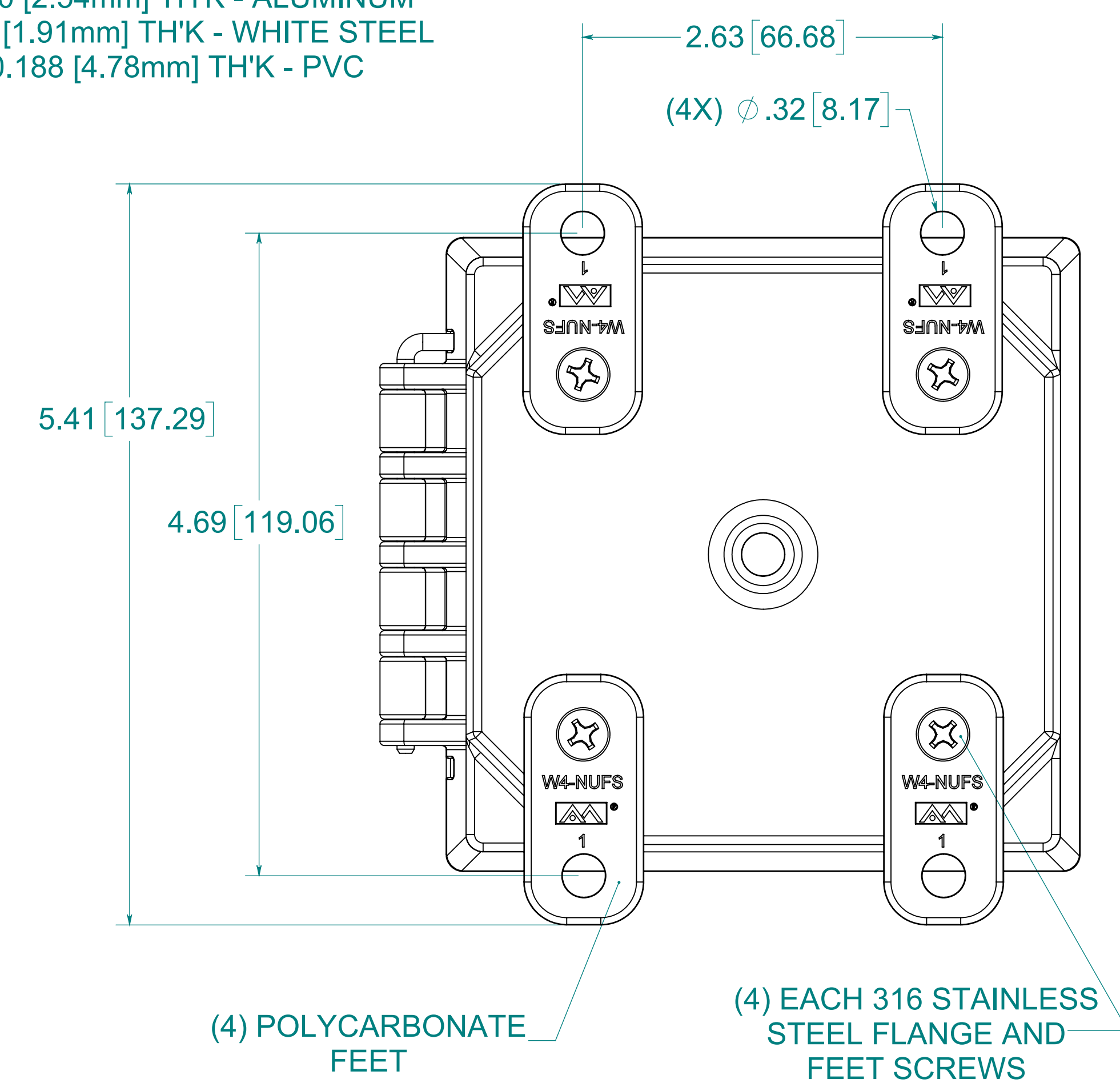

FIP POLYURETHANE GASKET

.14 [3.68] WALL THICKNESS

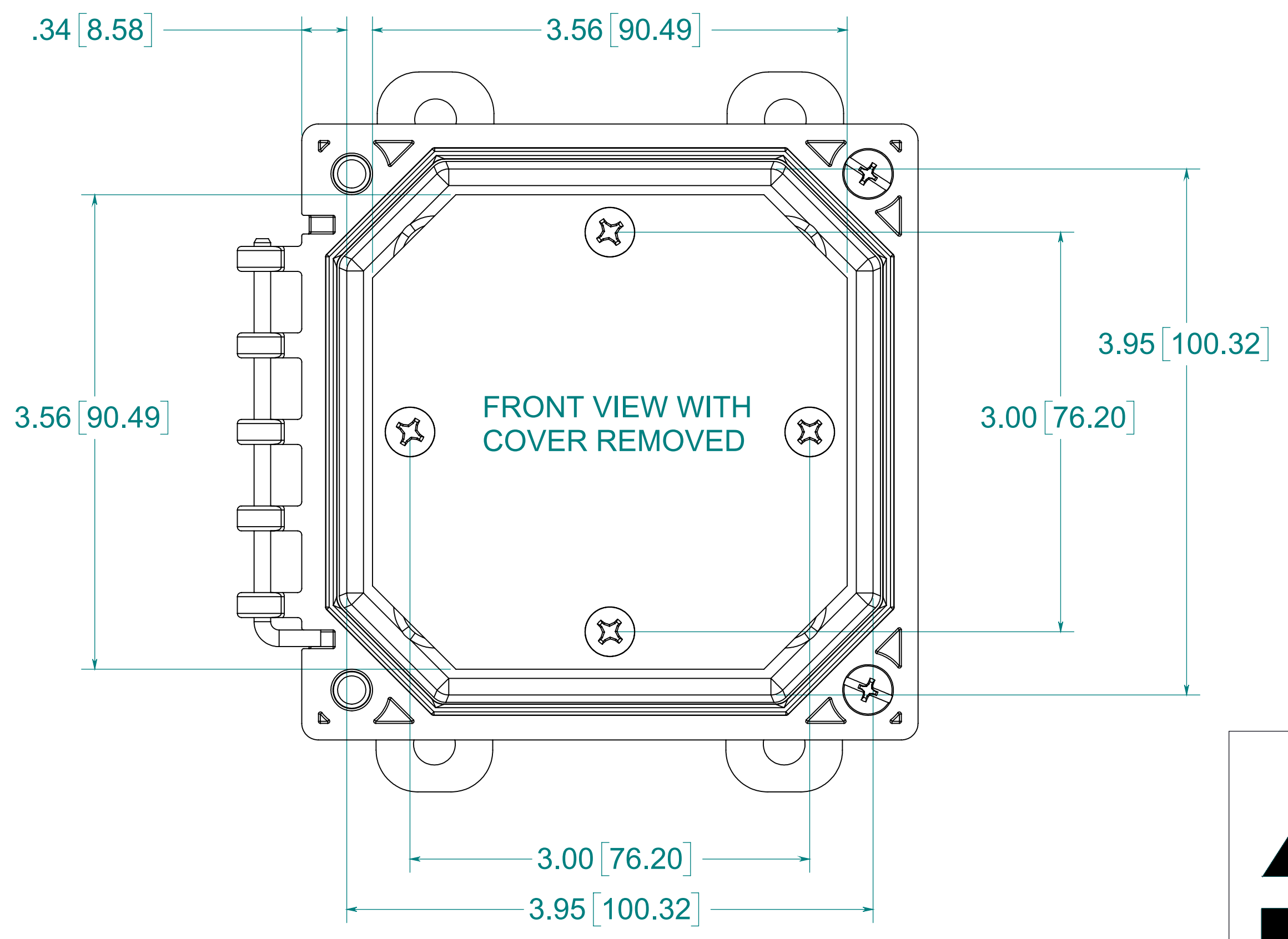
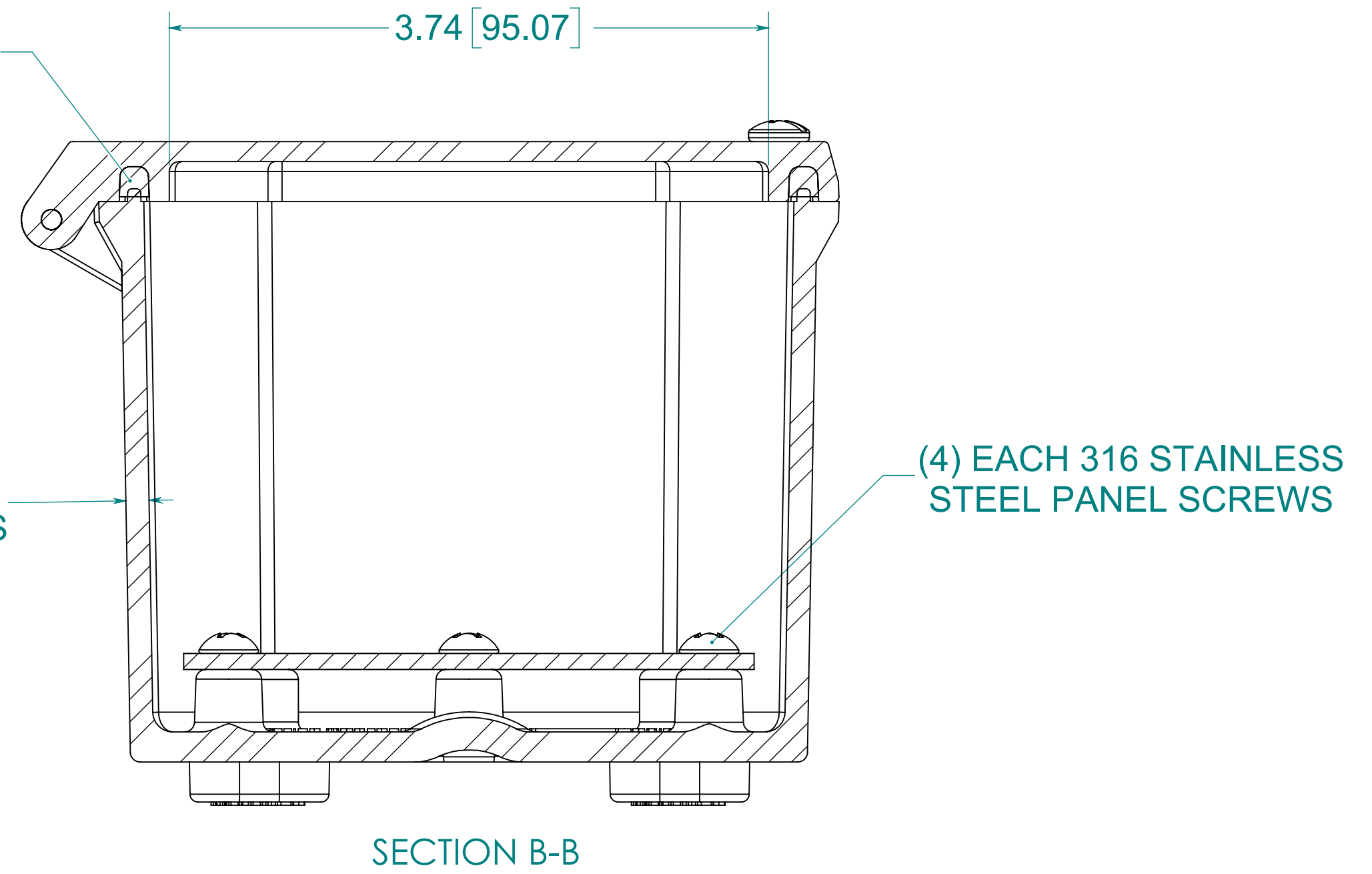

NOTE:
1. DATA SUBJECT TO CHANGE WITHOUT NOTICE

MATERIAL:
 BOX - INJECTED POLYCARBONATE
 STANDARD COVER - INJECTED POLYCARBONATE
 CLEAR COVER - INJECTED POLYCARBONATE

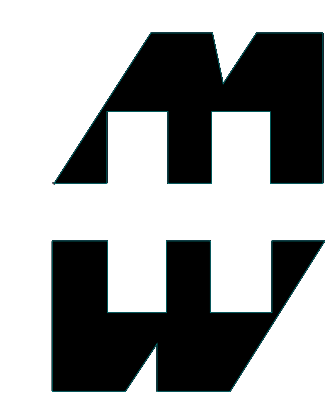

PART No. PCJ443CCH.WEB

for more information visit
www.hammfg.com
 Data subject to change without notice
 Drawing Not to Scale