

Isolation Power Transformers

UI5 Platform SMD



Pulse
a YAGEO company

- ② 2W LLC/SiC & GaN drive Transformer
- ② Reinforced insulation, 9.1mm creepage & 7mm clearance³
- ② 3750Vrms Hi-Pot isolation voltage
- ② Up to 900Vpk rated voltage⁴
- ② Footprint: 17.2 x 11x 8.5 mm MAX

Electrical Specifications @ 25°C - Operating Temperature -40°C to +125°C

Part Number	Inductance (1-3) (uH ±25%)	Leakage Inductance (uH TYP)	Capacitance (1,3) TO (6,4) (pF MAX)	DCR (1-3) (Ω MAX)	DCR (6-4) (Ω MAX)	E*T(1-3) ¹ (V*uSec)	Turns Ratio ±3.0%	Core Loss factor ³ KI	Hi-Pot Voltage (Vrms)
PMT6709NLT	23.5	3.45	2.5	0.23	1.66	28	1:3.64	14.88	3750

Notes:

1. The E*T rating limits the peak flux density to 2100 gauss (flux swing 4200 gauss). When used in bipolar drive applications.
2. The applied ET may need to be further derated for higher frequencies based on the temperature rise which results from the core and copper losses
 - A. To calculate total copper loss (W), use the following formula:
Copper Loss (W)=I_{rms_Primary}²*DCR_Primary+I_{rms_Secondary}²*DCR_Secondary
 - B. To calculate total core loss (W), use the following formula:
Core Loss (W)=9.738E-12*f^{1.878}*(E*T*KI)^{2.52}
Where f is the working frequency in KHz, E*T is the voltage*times in V*uSecond, KI is the Core Loss factor.
 - C. To calculate temperature rise, use the following formula: Temperature Rise (°C)
=125*(Core Loss(W)+Copper Loss (W))
3. Creepage and clearance is in accordance with IEC 61558-1 for reinforced insulation to a working voltage of 450Vrms (for basic insulation to a working voltage of 850Vrms) based on material group III, pollution degree 2, OVC II and 5000M altitude.
4. Rated voltage is based on a positive partial discharge test (discharge < 10pC) for the profile shown in page 3, in accordance with IEC60664 for basic insulation. In an application which requires a reinforced insulation barrier, a rated voltage of the equivalent peak voltage of the 450Vrms (sinusoidal) working voltage, 625Vpk, is defined and confirmed by partial discharge testing.

Mechanical

Schematic

PMT6709NLT

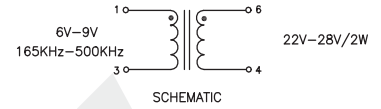
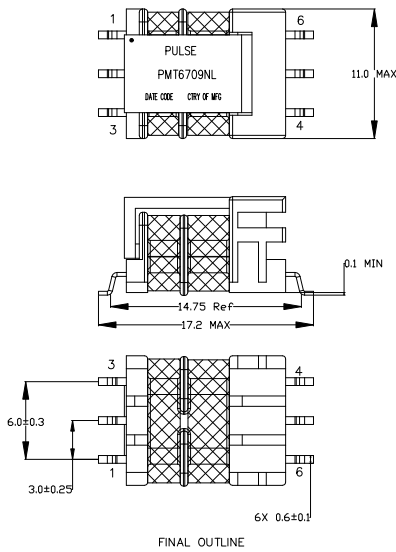

Weight1.6grams

Dimensions: mm
Unless otherwise specified,
all tolerances are ± 0.25

TAPE & REEL INFO

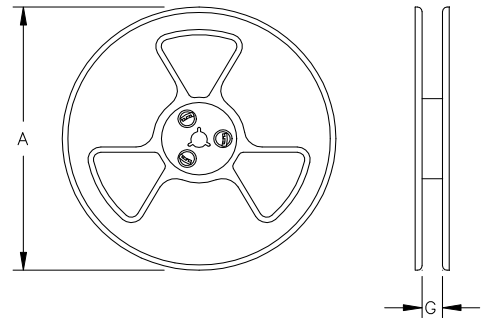
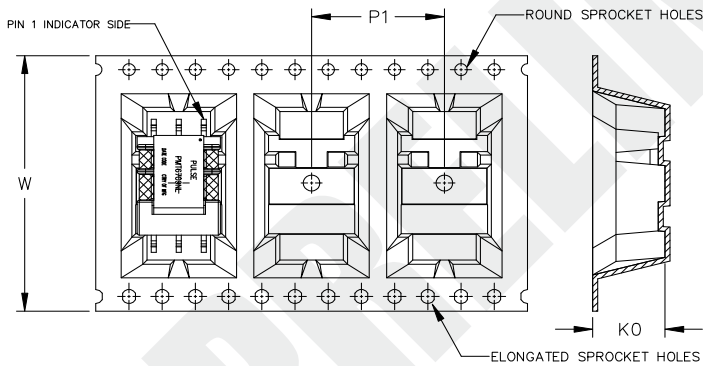

SURFACE MOUNTING TYPE, REEL/TAPE LIST

PART NUMBER	REEL SIZE (mm)		TAPE SIZE (mm)			QTY
	A	G	P ₁	W	K ₀	PCS/REEL
PMT6709NLT	Ø330	32.4	16	32	8.7	350

Partial Discharge Test Profile

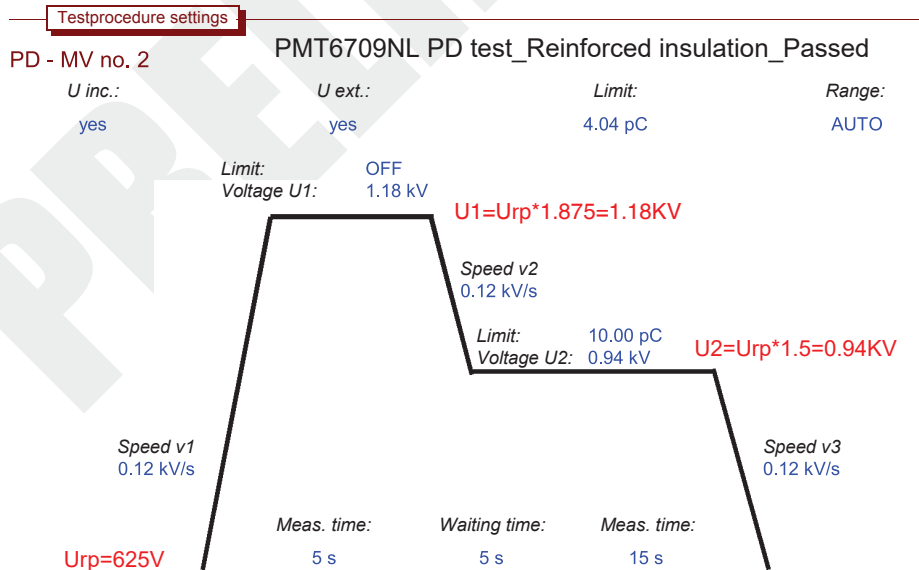
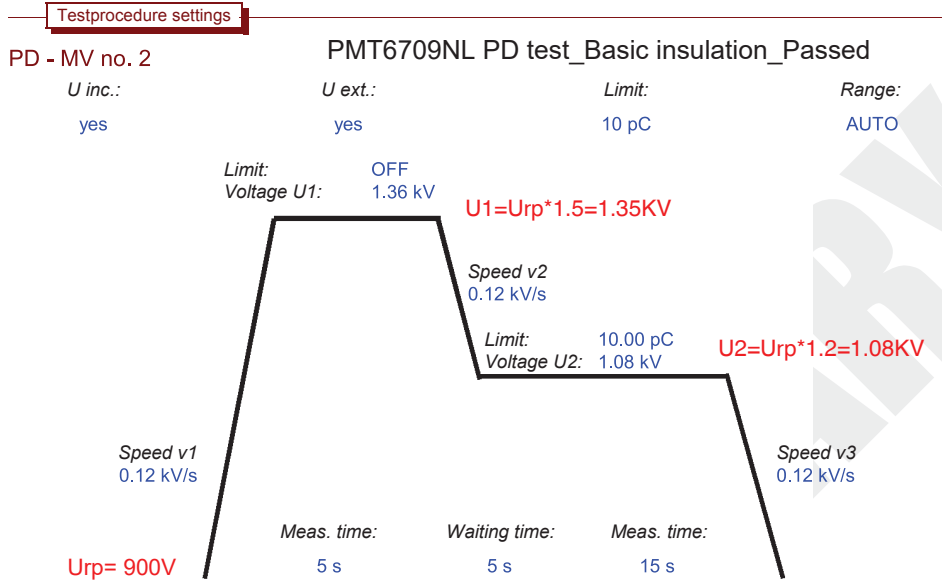

Isolation Power Transformers

UI5 Platform SMD

Application Note

Flyback and Push-Pull topologies have been widely used for MOSFET drive circuits. Tight coupling is necessary to minimise transformer leakage inductance, which enhances the efficiency of the drive circuit. However a tightly coupled transformer design results in relatively high interwinding capacitance, limiting higher switching frequency and the full utilisation of the benefits of using SiC/GaN Mosfets. Thus, it is difficult to simultaneously have low leakage inductance and low interwinding capacitance in a transformer.

This points to the significant benefit when using the LLC topology where a relatively high leakage inductance can be used as part of the resonant circuit, even replacing the need for an external resonant inductor. PMT6709NL utilizes a two-section bobbin, which naturally minimizes the interwinding capacitance while the leakage inductance increases to a level which contributes to the resonant inductance. The low capacitance enables an order of magnitude reduction in the common-mode current injection through the bias transformer, making this solution ideal for high frequency switching SiC/GaN Mosfet drive circuits. The soft-switching feature further reduces the EMI noise.

The below circuit shows how the LLC transformer can be used to provide positive and negative voltages for SiC/GaN device switching. The voltage required across the gate-source terminals of a SiC/GaN MOSFET is typically in the range of 14 to 20 V for full turn-on and 0 to -5 V for robust turn-off. PMT6709NL is suitable for this circuit and compatible with LLC controllers such as the TI UCC25800-Q1

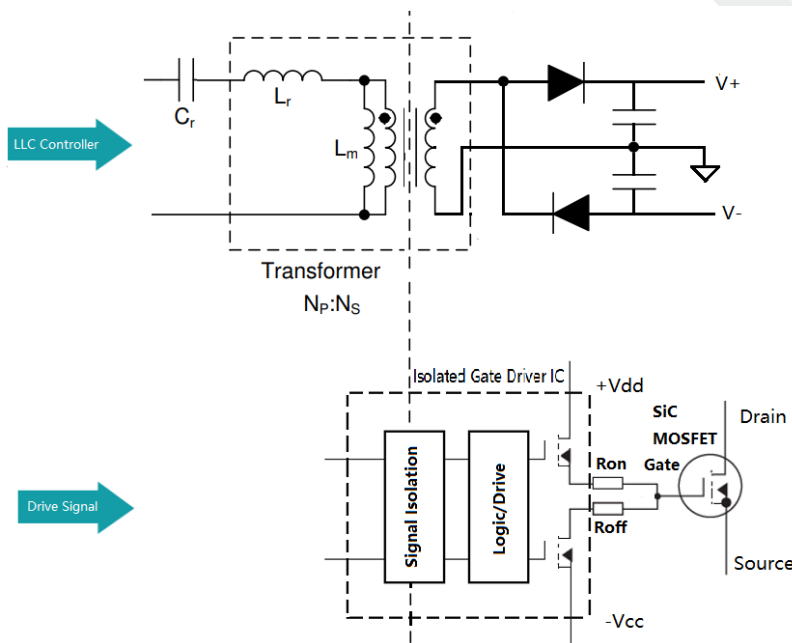

In addition to the providing galvanic isolation between the high-voltage and low-voltage sides, the purpose of the transformer is to satisfy the requirements of the relevant safety standards. PMT6709NL is designed to comply with the IEC61558-1 & -2/16 for basic and reinforced insulation. With 9.5mm creepage distance and based on material group III, OVCII and 5000m altitude, this corresponds to a maximum working voltage of 850Vrms for basic insulation and 450Vrms for reinforced insulation. Contact your Pulse Electronics representative for other required output voltages and safety requirements.

For More Information:

Americas - prodinfo_power_americas@yageo.com | Europe - prodinfo_power_emea@yageo.com | Asia - prodinfo_power_asia@yageo.com

Performance warranty of products offered on this data sheet is limited to the parameters specified. Data is subject to change without notice. Other brand and product names mentioned herein may be trademarks or registered trademarks of their respective owners. © Copyright, 2023. Pulse Electronics, Inc. All rights reserved.