

BCN25-700-8

3 Phase On-Board Battery Charger

The BCN25-700-8 is a 25 kW on-board battery charger that converts 3-phase AC voltage to DC voltage. The on-board battery charger is liquid cooled.

Features include very high efficiency, high reliability and compact dimensions.

Key Features & Benefits

- Up to 25 kW Output Power
- 93% Typical Efficiency
- AC 3-phase input 460 - 575 VAC +/-10% (Line-Line)
- DC Output 250 - 800 VDC, 37.5 ADC
- J1939 Compliant CAN Control and Monitoring
- Over-temperature, Output Over-voltage and Over-current Protections
- SAE 1455 Complaint Environmental Standards
- IP65 and IP67 Rating, Stackable Chassis
- Agency approved to UL2202 - Standard for Electric Vehicle (EV) Charging System Equipment

Applications

- Charging of Hybrid / Full Electric Vehicles operating in Mining Environment and in Industrial Environment.



1. INPUT SPECIFICATIONS

PARAMETER	DESCRIPTION / CONDITION	MIN	NOM	MAX	UNIT
Input Line-Line Voltage	Nominal Operating Range	460		575	VAC
	Absolute Operating Range	414		632	
Input Current				40	Arms
Frequency		47	50 / 60	63	Hz
Input Line Under-voltage		390	400	410	VAC
Leakage Current	@ 3x632 VAC, 60 Hz			10	mA
Inrush Current	Active Limiter Included				
Power Factor	@ Vin = 3x460 VAC, Po = 25 kW	0.9			
Line Harmonic Current (THD)	@ Vin = 3x460 VAC, Po = 25 kW ¹			32	%
Signal Battery DC Input	VBAT_IN	10.5		32	V

2. OUTPUT SPECIFICATIONS

PARAMETER	DESCRIPTION / CONDITION	MIN	NOM	MAX	UNIT
Output Type	DC current source				
Output Voltage	Not regulated; depends on battery voltage	250	666	800	VDC
Output Current	Average output current adjustable via CAN			37.5	ADC
Output Power				25	kW
Efficiency	@ Vin = 3x460 VAC, Vo_nom, Po_nom		93		%
Static Regulation	Charge Mode: Set Point Accuracy @ Idcset = 30 A, Tcoolant = 25°C Thermal Drift after 15 min warm up period	- 1		+ 1	ADC %/°C
		- 0.05		+ 0.05	
Turn-On/Off Delay	Turn-On Delay / Ramping			3 / 12	s
	Turn-Off Delay			1	

3. PROTECTION SPECIFICATIONS

PARAMETER	DESCRIPTION / CONDITION	MIN	NOM	MAX	UNIT
Output Over-Current Protection	CAN adjustable	1		37.5	Arms
Short Circuit Survival - Operating	Self-protecting; Hiccup mode				
Output Over-Voltage Protection	CAN adjustable	200		840	VDC
Output Under-Voltage Protection	Hiccup mode, CAN adjustable threshold	200		840	VDC
Over-Temperature Protection	Converter shutdown at T_coolant higher than	65			°C
	CAN: CHG_BB_TEMP (chassis temperature) shutdown CHG_AMB_TEMP (ambient inside temp) shutdown		84 94		
Input Overvoltage Protection		635		650	VAC

¹ The charger is not intended to be connected directly in public grid, because it does not meet EN61000-3-12 for harmonics current emissions. According to EN 55011, part 6, it can be used only in industrial environment, input connected to a dedicated power transformer or generator, at locations where there is a distance greater than 30 m between this equipment and third party sensitive radio communications.

4. MONITORING AND CONTROL SIGNALS

PARAMETER	DESCRIPTION / CONDITION
KEY_SWITCH_IN	CAN communication enable Level High = Enable
Control Pilot	Function and levels according to SAE J1772 *not implemented in current SW
Proximity Detection	Function and levels according to SAE J1772 *not implemented in current SW
LED_OUT	PWM current source max 50mA. Supplied from battery voltage input (VBAT 12V) PWM controlled with CAN bus.
VBAT_IN	12V or 24V battery input. Used to supply also CAN bus communication. Max. standby current < 8mA@24V
EVSE_WAKE_OUT	Energy taken from VBAT. Voltage level is approximately 1.5V below connected VBAT. High side output wake VCU and other vehicle control modules and/or relay coils. Wake output goes high when control pilot is active (or simulated by CAN) and goes low when CAN command from VCU is received or in sleep Mode.
HVIL_IN	Input to supply of HVIL loop
HVIL_OUT	Output from HVIL loop
ADR0_IN, ADR1_IN	4 address possibilities
CAN_BAUD_RATE_IN	CAN bus speed; Open – 500 kbps / Grounded – 250 kbps

5. SAFETY, REGULATORY AND EMI SPECIFICATIONS

PARAMETER	DESCRIPTION / CONDITION	CRITERION
Safety Standards	ANSI / UL 2202	
Insulation	Signals to Primary	Basic 2250 VDC
	Signals to Secondary	Basic 2250 VDC
	Primary to Secondary	Basic 2250 VDC
	Signals RTN to PE	Electrically connected together ²
	Primary to PE	Basic 2250 VDC
	Secondary to PE	Basic 2250 VDC
Radiated Emission	EN 55011	Class A, Group 1
Conducted Emission	EN 55011	Class A, Group 1
Electrostatic Discharge	IEC 61000-4-2	Performance Criterion B
Radiated Electromagnetic Field	IEC 61000-4-3, SAE J1113/21	Performance Criterion B, Status 2
Electrical Fast Transient (EFT) /Burst	IEC 61000-4-4; Level 2 (+/-2 kV, 5 kHz)	Performance Criterion B
Surge Immunity	IEC 61000-4-5; Level 3 surge (+/-1 kV CM and +/-2 kV DM)	Performance Criterion B
RF Conducted Immunity	IEC 61000-4-6; Level 3 (10V, 0.15-80 MHz, AM 80%, 1 KHz)	Performance Criterion A
Flicker Tests	IEC 61000-3-3	
Electrical Transient Conduction along Supply Lines	ISO 7637-2, ISO 16750-2	

6. ENVIRONMENTAL SPECIFICATIONS

PARAMETER	DESCRIPTION / CONDITION	MIN	NOM	MAX	UNIT
Altitude	Non-Operating: 18.6 kPa absolute pressure			12200	m
	Operating:			2000	
Operating Temperature	Liquid cooled: T_coolant T_ambient	-40		+65	°C
		-40		+65	
Storage Temperature		-40		+85	°C
Humidity	SAE J1455				
Shock	SAE J1455, GMW-3172				
Vibration	SAE J1455, GMW-3172				

² Due to referencing of Control Pilot and Proximity against PE/chassis (SAE J1772)

Protection IP65 and IP67 *when all mating connectors are installed

7. CONNECTORS

AC INPUT CONNECTOR

Amphenol PL4 with HVIL pins, MPN: PL084 X 41-6;
Mating part PL184 X 41-6

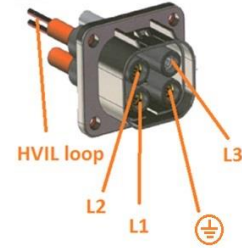

DC OUTPUT CONNECTOR

DC side connector with HVIL Amphenol PL 082 X-61-6
Mating part PL 182 X-61-6

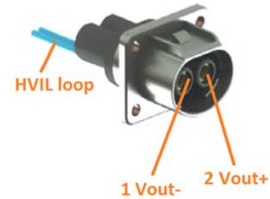

SIGNAL CONNECTOR

Tyco 776087-1; Mating part: 770680-1 + 770520-1

Max. 2 Amps per pin (wire AWG 20)

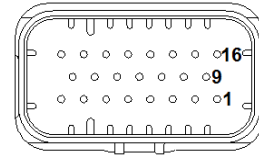

PIN	NAME	SIGNAL REFERENCE	FUNCTION	LOW LEVEL HIGH LEVEL	Vmax Imax
1	LED_OUT	24V_RTN	Charger status LED	Current source	VBAT_IN-1.5 V 50 mA
2	VBAT_IN	24V_RTN	24V battery voltage input	10.5-32 Vdc	32 V 2 A
3	CANH_1		CAN Bus H	-	-27 to 40 Vdc 15 mA
4	CANL_1		CAN Bus L	-	-27 to 40 Vdc 15 mA
5	HVIL_OUT		HVIL output from AC and DC connector	Open loop	32 V 60 mA
6	HVIL_IN		Input for HVIL loop	Power by 10.5-32 Vdc	32 V
7	Control Pilot	24V_RTN	SAE J1772		SAE J1772 compatible
8	Proximity Detection	24V_RTN	SAE J1772		SAE J1772 compatible
9	24V_RTN	-	Return for 24V battery and signals	-	-
10	ADRO_IN	24V_RTN	Address bit 0	Pulled-up to H L: connect to 24V_RTN	3.3 to 32 Vdc
11	ADR1_IN	24V_RTN	Address bit 1	Pulled-up to H L: connect to 24V_RTN	3.3 to 32 Vdc
12	EVSE_WAKE_OUT	24V_RTN	Signal to wake up Vehicle Control Unit (VCU module)	0 VBAT_IN-1.5 V	VBAT_IN-1.5 V 200 mA
13	KEY_SWITCH_IN	24V_RTN	Power supply of CAN and Bias converter Enable	OFF: <3.5 V ON: 7.7 - 32 V	32 V 0.5 mA
14	CAN_BAUD_RATE_IN	24V_RTN	Open - 500 kbps; Grounded - 250 kbps	Pulled-up to H L: connect to 24V_RTN	3.3 to 32 Vdc
15	NA				
16	NA				
17	NA				
18	CANH_2		CAN Bus H	-	-27 to 40 Vdc 15 mA
19	CANL_2		CAN Bus L	-	-27 to 40 Vdc 15 mA

20 - 23 NA

8. COOLING SPECIFICATIONS

PARAMETER	DESCRIPTION / CONDITION
Cooling Type:	Liquid cooling
Coolant Medium/Mixture:	50/50 Glycol/Water
Coolant Flow:	Min. 5 LPM
Max. coolant pressure:	15 psi
Max. pressure drop:	3 psi
Inlet/Outlet Coolant Connection:	SAE fittings with outer thread 1-14UNS for internal hose size $\geq 5/8"$ (e.g. Parker p/n: 10F50MLOSS)
Material of fittings:	Stainless steel
Fittings provided with inverter charger:	2pcs Parker p/n: 10F50MLOSS or equivalent

9. MECHANICAL SPECIFICATIONS

PARAMETER	DESCRIPTION / CONDITION
Dimensions (L x W x H)	524 x 340 x 84 mm
Weight	19.4 kg
Enclosure Material	Aluminum alloy

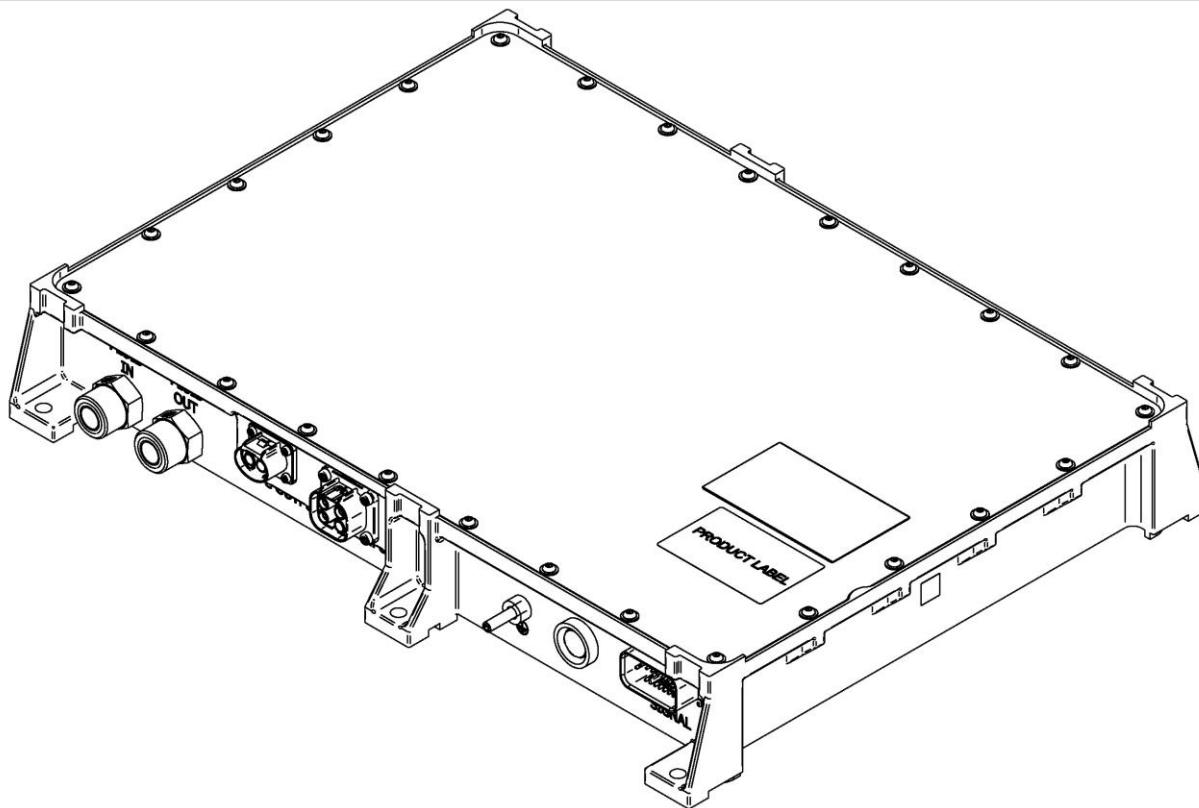

Figure 1. Mechanical Design – ISO view

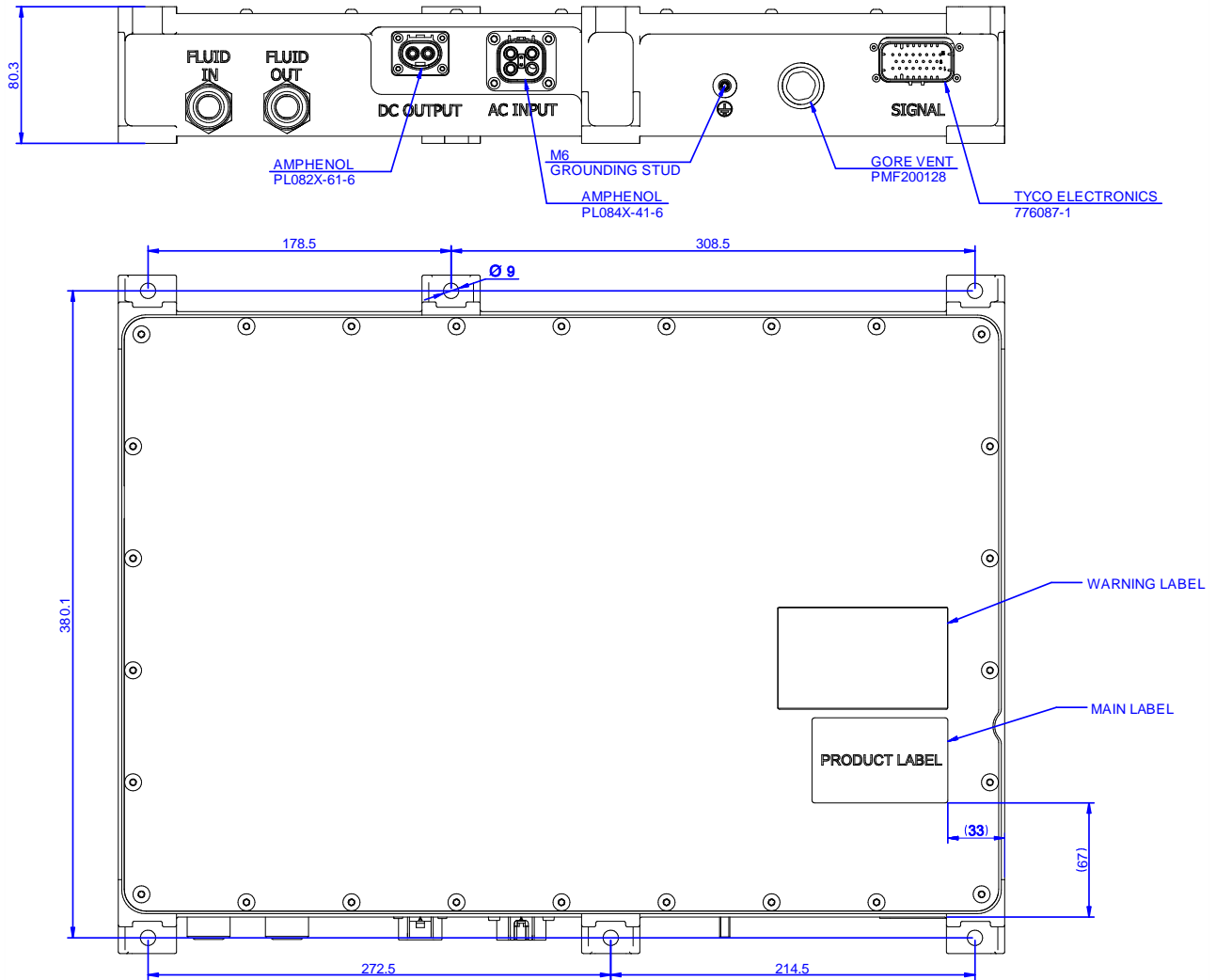

Figure 2. Mechanical Dimensions

For more information on these products consult: tech.support@psbel.com

NUCLEAR AND MEDICAL APPLICATIONS - Products are not designed or intended for use as critical components in life support systems, equipment used in hazardous environments, or nuclear control systems.

TECHNICAL REVISIONS - The appearance of products, including safety agency certifications pictured on labels, may change depending on the date manufactured. Specifications are subject to change without notice.



Asia-Pacific
+86 755 298 85888

Europe, Middle East
+353 61 225 977

North America
+1 408 785 5200