

POWER RELAY

1 POLE - HIGH CAPACITY 32A TYPE

FTR-K3-PS Series

RoHS Compliant



■ FEATURES

- 1 pole, 32A
- 1 form A contact
- Wide contact gap: 1.8mm
(Compliant with European photovoltaic standard VDE0126)
- High insulation in small package (between coil and contacts)
 - Dielectric strength: AC 4,000V
 - Surge strength: 6,000V
- Low coil power consumption: 1,400mW
- Coil holding voltage can be reduced up to 35% of nominal coil voltage
(ambient temperature; +20°C, contact current; 32A)
Power consumption at the lowest coil holding voltage; 171.5mW
* Coil holding voltage is the coil voltage after 100ms of applied nominal coil voltage
- Plastic materials: Flammability; UL94 V-0
- Cadmium-free contacts
- Flux free, cat. RTII protection
- RoHS compliant



■ APPLICATIONS

Photovoltaic power generation system (power conditioner), Uninterruptible Power Supply (UPS)

■ PART NUMBERS

[Example] FTR-K3 A B 012 W - PS
 (a) (b) (c) (d) (e) (f)

(a)	Relay type	FTR-K3 series
(b)	Contact configuration	A : 1a (1 Form A) / PCB type
(c)	Coil power	B : Standard (1,400mW)
(d)	Coil rated voltage	12 : 5...48VDC Please refer to coil rating table
(e)	Contact material	W : Silver alloy
(f)	Option code	PS : High current (32A) / contact gap 1.8mm

Actual marking does not carry the type name : "FTR"

E.g.: Ordering code: FTR-K3AB012W-PS Actual marking: K3AB012W-PS

■ SPECIFICATIONS

Item		Specifications	Remarks/Conditions	
Contact Data	Configuration	1a (1 Form A)		
	Material	Silver alloy		
	Resistance (initial)	Max. 100mΩ	At 1A, 6VDC	
	Contact rating	32A, 250VAC	Resistive	
	Max. carrying current	32A		
	Max. switching voltage	250VAC		
	Max. switching power	8,000VA		
	Max. switching current	32A		
	Min. switching load ^{*1}	100mA, 5VDC	Reference	
Coil	Rated power (20°C)	1,400mW		
	Operate power (20°C)	686mW		
	Coil power at holding voltage	171.5mW (35% of nominal coil voltage)		
	Holding voltage range ^{*2}	35 to 120% of nominal coil voltage (32A at +20°C) 45 to 80% of nominal coil voltage (32A at +85°C)		
	Operating temperature range	-40°C to +60°C (coil nominal voltage) -40°C to +85°C (holding voltage: 45~80% of nominal coil voltage)	No frost	
Time	Operate (at nominal voltage)	Max. 20ms (without bounce)		
	Release (at nominal voltage)	Max. 10ms (no diode, without bounce)		
Life	Mechanical	Min. 100 x 10 ³ operations		
	Electrical	Resistive	Min. 30 x 10 ³ operations (at 32A, 250VAC)	
		Inductive (Endurance)	Min. 30 x 10 ³ operations (at 32A, 250VAC, cosφ=0.8)	
	Inductive (Overload)	Min. 50 operations (at 48A, 250VAC, cosφ=0.8)		
Insulation	Contact gap	Min. 1.8mm		
	Resistance	Min. 1,000MΩ	At 500VDC	
	Dielectric strength	Open contacts	2,500VAC (50/60Hz), 1 minute	
		Coil to contacts	4,000VAC (50/60Hz), 1 minute	
	Surge strength	Coil to contacts	6,000V / 1.2 x 50μs standard wave	
	Clearance		Min. 6.0mm	
	Creepage		Min. 8.0mm	
	EN61810-1, VDE0435	Voltage	250VAC	
Pollution degree		3		
Material group		IIIa		
Others	Vibration resistance	Misoperation	10 to 55 to 10Hz single amplitude 0.75mm	Coil ON/OFF, 3 axis, total 6 cycles
		Endurance	10 to 55 to 10Hz single amplitude 0.75mm	Coil OFF, 3 axis, total 6 hours
	Shock resistance	Misoperation	Min. 200m/s ² (11±1ms)	Coil ON/OFF, 3 axis, total 36 operations
		Endurance	Min. 1,000m/s ² (6±1ms)	Coil OFF, 3 axis, total 18 operations
	Dimensions / Weight		15.7 x 30.1 x 23.3mm / Approximately 26g	

*1 Minimum switching loads mentioned above are reference values. Please perform the confirmation test with actual load before production since reference values may vary according to switching frequencies, environmental conditions and expected reliability levels.

*2 Coil holding voltage is the coil voltage after 100ms of applied nominal coil voltage.

! Care shall be taken on the heat generated on PC board when maximum carrying current exceeds 10A. Please perform the confirmation test with actual conditions.

■ COIL DATA

Coil Code	Rated Coil Voltage (VDC)	Coil Resistance $\pm 10\%$ (Ω)	Must Operate Voltage ^{*1} (VDC)	Must Release Voltage ^{*1} (VDC)	Min. Non Release Voltage ^{*1} (VDC)	Rated Power (mW)
005	5	18	3.5	0.5	1.75	1,400 (171.5) ^{*2}
006	6	26	4.2	0.6	2.1	
009	9	58	6.3	0.9	3.15	
012	12	103	8.4	1.2	4.2	
018	18	231	12.6	1.8	6.3	
024	24	410	16.8	2.5	8.4	
048	48	1,650	33.6	4.8	16.8	

Note: All values in the table are valid for 20°C and zero contact current.

*1: Specified operate values are valid for pulse wave voltage.

*2: This value is the coil power at 35% of nominal voltage at 20°C.

! Please use at rated coil voltage. Please refer to characteristic data and set up adequate voltage in case of use at over voltage.

■ SAFETY STANDARDS

Type	Compliance	Contact Rating
UL	Flammability: UL 94-V-0 (plastics)	
	UL 508 CSA 22.2 No.14 (cULus) File No. E63614	32A, 277VAC (General use, at 85°C) 1hp 125VAC (at 60°C) 2hp 277VAC (at 60°C, 100K operations)
VDE	IEC/EN61810-1	32A, 250VAC (cosφ=0.8 at +85°C)

■ PART NUMBER LIST

Part Number	Contact Configuration	Contact Gap	Contact Material	Contact Rating	Rated Coil Power
FTR-K3AB()W-PS	1a (1 Form A)	Min. 1.8mm	Silver alloy	32A, 250VAC	1,400mW

■ DIMENSIONS

• Dimensions

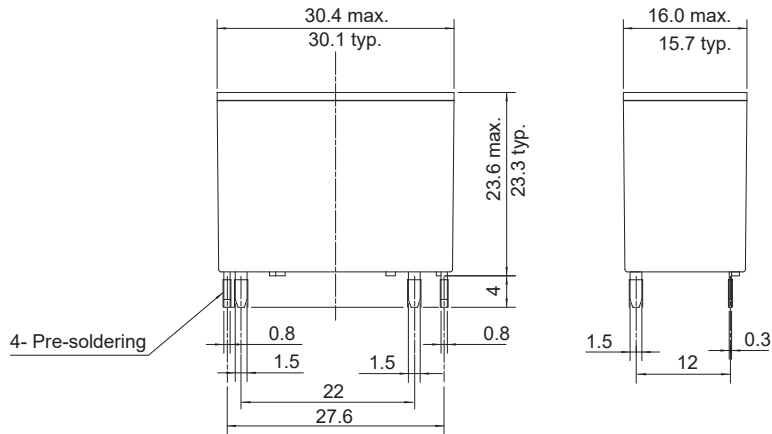

• Schematics

(BOTTOM VIEW)

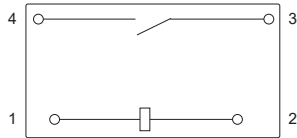

• PC board mounting hole layout

(BOTTOM VIEW)

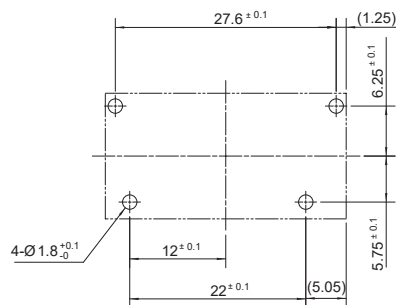

- Dimensions of the terminals do not include thickness of pre-soldering.
- Tolerance of PC board mounting hole layout : ± 0.1 unless otherwise specified.

Unit: mm

(): Reference

CHARACTERISTIC DATA

(Characteristic data is not guaranteed value but measured values of samples from production line.)

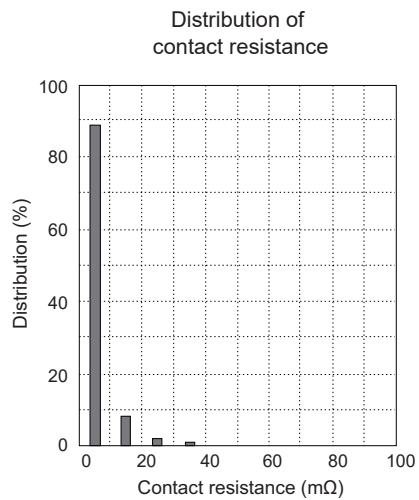
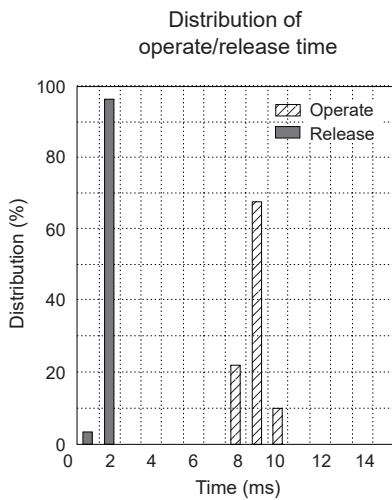
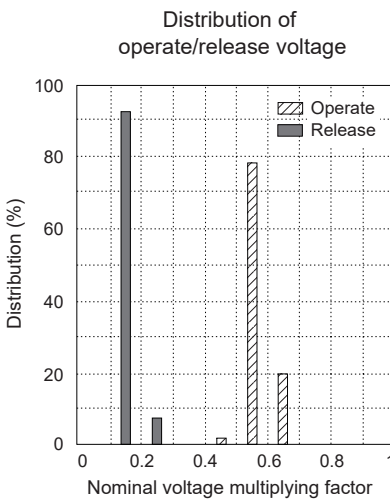
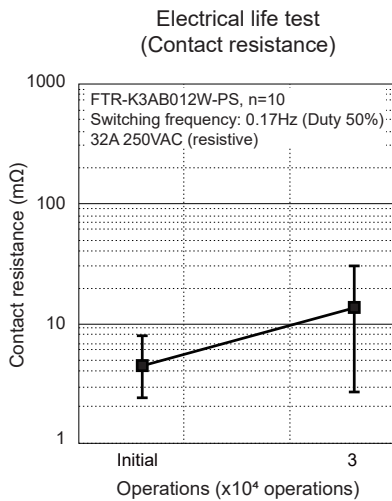
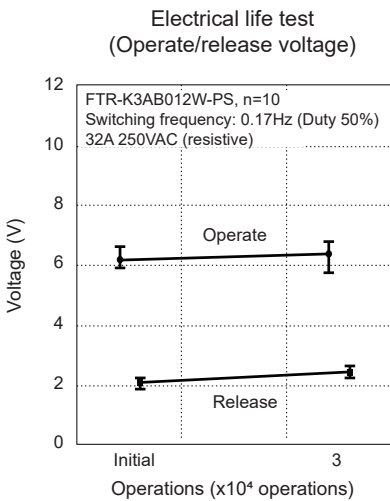
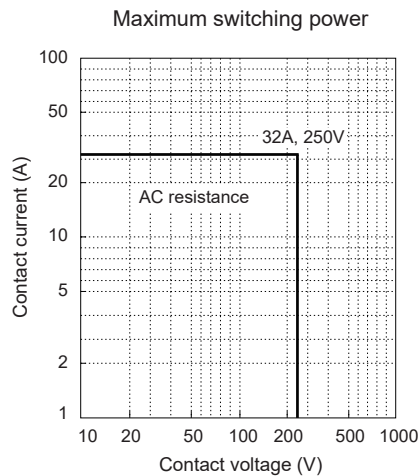
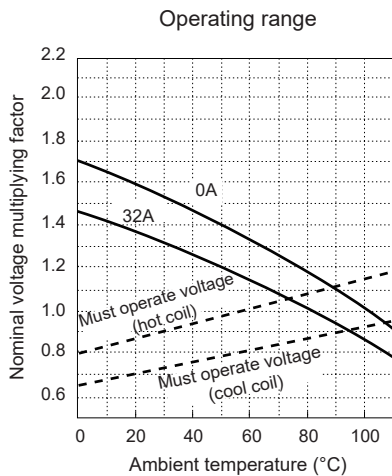
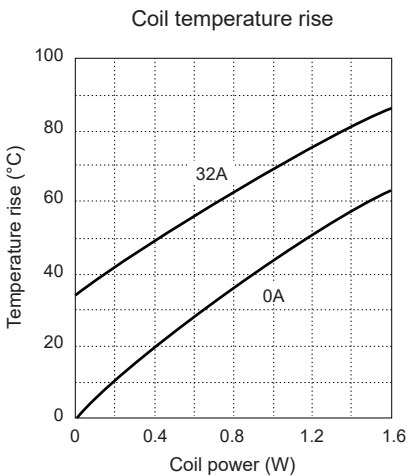

CAUTIONS

- All values mentioned in this datasheet are provided under ideal conditions. Please perform the confirmation test before actual use.
- Reflow soldering is prohibited.
- Do not use relays in the atmosphere with sulfide gas, chloride gas or nitric oxide. Contact resistance may increase.
- Do not use silicon or silicon-containing product or materials near relays. It may cause contact failure.

GENERAL INFORMATION

1. ROHS Compliance

- All relays produced by FCL Components are compliant with RoHS directive 2011/65/EU, including commission delegated directive 2015/863.

2. Recommended lead free solder condition

- Lead free solder plating on relay terminals is Sn-3.0Ag-0.5Cu, unless otherwise specified. This material has been verified to be compatible with PbSn assembly process.
- Recommended solder for assembly: Sn-3.0Ag-0.5Cu.

Flow Solder Condition:

Pre-Heating: Maximum 120°C within 90 sec.

Soldering: Dip within 5 sec. at 255°C±5°C solder bath

Relay must be cooled by air immediately after soldering

Solder by Soldering Iron:

Soldering Iron: 30-60W

Temperature: Maximum 340-360°C

Duration: Maximum 3 sec.

We highly recommend that you confirm your actual solder conditions

3. Moisture Sensitivity

- Moisture Sensitivity Level standard is not applicable to electromechanical relays, unless otherwise indicated.

4. Tin Whiskers

- Dipped SnAgCu solder is known as presenting a low risk to tin whisker development. No considerable length whisker was found by our in-house test.

Contact

Japan

FCL COMPONENTS LIMITED
Shinagawa Seaside Park Tower
12-4, Higashi-shinagawa 4-chome,
Tokyo 140 0002, Japan
Tel: +81-3-3450-1682
Email: fcl-contact@cs.fcl-components.com

North and South America

FCL COMPONENTS AMERICA, INC.
2055 Gateway Place Suite 480,
San Jose, CA 95110 USA
Tel: +1-408-745-4900
Email: contact@fcl-components.us

Europe

FCL COMPONENTS EUROPE B.V.
Diamantlaan 25
2132 WV Hoofddorp, Netherlands
Tel: +31-23-556-0910
Email: info@fcl-components.eu

Asia Pacific

FCL COMPONENTS ASIA PTE LTD.
51 Changi Business Park Central 2, #06-07
The Signature Singapore 486066
Tel: +65-6375-8560
Email: fcal@fcl-components.com

China

FCL COMPONENTS (SHANGHAI) CO.,LTD.
Unit 1105, Central Park - Jing An,
No.329 Heng Feng Road, Shanghai
200070, China
Tel: +86-21-3253 0998
Email: fcsh@fcl-components.com

Hong Kong

FCL COMPONENTS HONG KONG CO.,
LIMITED
Unit 2313, Seapower Tower, Concordia
Plaza, No.1 Science Museum Road,
TST, Kowloon, Hong Kong
Tel: +852-2881-8495
Email: fcal@fcl-components.com

Web: www.fcl-components.com/en/

© 2026 FCL Components Limited. All rights reserved. All trademarks or registered trademarks are the property of their respective owners.

FCL Components Products are intended for general use, including without limitation, in personal, household and office environments, in buildings and for ordinary use in the industry. FCL Components Products are not intended to be used in applications where extremely high safety is required ("High Safety Required Applications"), such as, but not limited to, applications in nuclear facilities, in aircraft automatic flight control, in air traffic control, in mass transit system control, in missile launch system, in weapon systems, in medical equipment for life support or any application involving a direct serious risk of physical injury or death.

Please do not use FCL Components Products without securing the sufficient safety and reliability required for the High Safety Required Applications.

In addition, FCL Components shall not be liable against the customer and/or any third party for any claims or damages arising in connection with the use of FCL Components Products in the High Safety Required Applications.

FCL Components warrants that its Products, if properly used and services, will conform to their specification and will be free from defects in material and workmanship for twelve months from delivery.

The implied warranties of merchantability and fitness for a particular purpose and all other warranties, representations and conditions, express or implied by statute, trade usage or otherwise, except as set forth in this warranty, are excluded and shall not apply to the Products delivered.

The contents, data and information in this datasheet are provided by FCL Components Limited as a service only to its user and only for general information purposes. The use of the contents, data and information provided in this datasheet is at the users' own risk.

FCL Components has assembled this datasheet with care and will endeavor to keep the contents, data and information correct, accurate, comprehensive, complete and up to date.

FCL Components Limited and affiliated companies do however not accept any responsibility or liability on their behalf, nor on behalf of its employees, for any loss or damage, direct, indirect or consequential, with respect to this datasheet, its contents, data, and information and related graphics and the correctness, reliability, accuracy, comprehensiveness, usefulness, availability and completeness thereof. Nor do FCL Components Limited and affiliated companies accept on their behalf, nor on behalf of its employees, any responsibility or liability with respect to these datasheets, its contents, data, information and related graphics and the correctness, reliability, accuracy, comprehensiveness, usefulness, availability and completeness thereof. Rev. February 9, 2026.