

*Not for NEW DESIGN*

# Thermal Printer

FTP-839MCL113 series (Easy loading, curl pass)

FTP-839MCL114 series (Auto loading, straight pass)

3" 24V Driving mechanism

## Overview

The high-speed FTP-839MCL series is a 24V driven mechanism for 3 inch wide paper. The mechanism has no control board.

The receipt/label printer mechanism is most suitable for applications such as Kiosk, ATM, lottery, pharmacy, and ticket issuing printers for various other equipment.

## Features

- High resolution 300 dpi (11.8 dots/mm)
- Ultra high-speed (200mm/sec.)
- Medium duty united (mounting is easy)
- Up to 10-inch paper roll diameter
- Rear paper auto loading
- Paper jam detection
- Prints 2-D barcodes
- UL file no. E171434

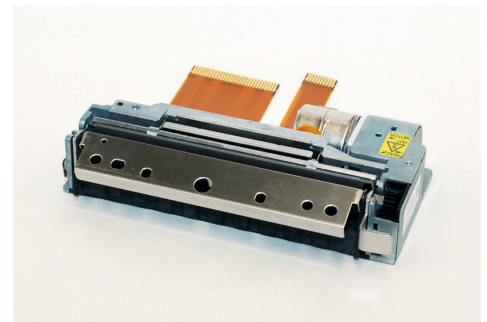

FTP-839MCL series

## ■ Designation

Item		Part Number	Comment
Printer mechanism	USB (ver. 2.0)	FTP-839MCL113	Easy load, curved paper path
	Serial (RS-232C) / USB (ver. 2.0)	FTP-839MCL114	Auto load, straight paper path

## ■ Specifications

Item	Specifications		
Part number	FTP-839MCL113/114		
Printing method	Thermal-sensitive line dot method		
Dot structure	960dots/line		
Dot pitch	Horizontal	0.0847 mm (dot density: 11.8 dots/mm, 300dpi)	
	Vertical	0.0847 mm (line feed pitch; 11.8 dots/mm, 300dpi)	
Effective printing area	81.312 mm		
Paper	Width	86±1 mm (standard setting)	
	Thickness	60 to 100 µm (depending on paper specifications)	
Printing speed	Max. 200 mm/s (2,360 dotlines/s) (High speed batch image printing, at 25°C using PD150R Oji paper)		
Interface	Serial (RS232C), USB		
Power supply	For head	24VDC ±10%, approx. 3.22A (24VDC, 970Ω, + 25°C, concurrent applied dot number 128 dots)	
	For printer motor	24VDC ±10%, 1.0 A maximum (FCL Component Limited standard circuit)	
	For logic	5VDC ±5%, 0.32 A maximum or 3.3VDC±5%, 0.12A maximum	
Dimensions (WxDxH)	104.2 x 51.6 x 20.5 mm		
Weight (approximately, excluding paper)	145 g		
Expected life	Head	Pulse resistance	100 million pulse/dot (using Meiko Electronic Components's standard printing conditions)
		Wear resistance	100 km (at max. 12.5% printing ratio (using Meiko Electronic Components' standard printing conditions)
Environmental conditions	Operating temperature		-10°C to +60°C*1
	Operating humidity		20 to 85% RH (no condensation) (at 0 to +40°C)
	Storage temperature		-40°C to +70°C
	Storage humidity		5 to 90% RH (no condensation)
Detection	Motor head temperature		By thermistor (applied energy control, abnormal temperature detection)
	Paper out/Mark detect		By photointerrupter
	Platen open		By mechanical switch
Recommended thermal sensitive paper	PD150R (Oji paper) (Standard paper)		
Paper diameter	Max. 83 mm		

\*1: Color density is guaranteed: +5° to +40°C with PD150R (Oji paper).

■ Dimensions

- FTP-839MCL113

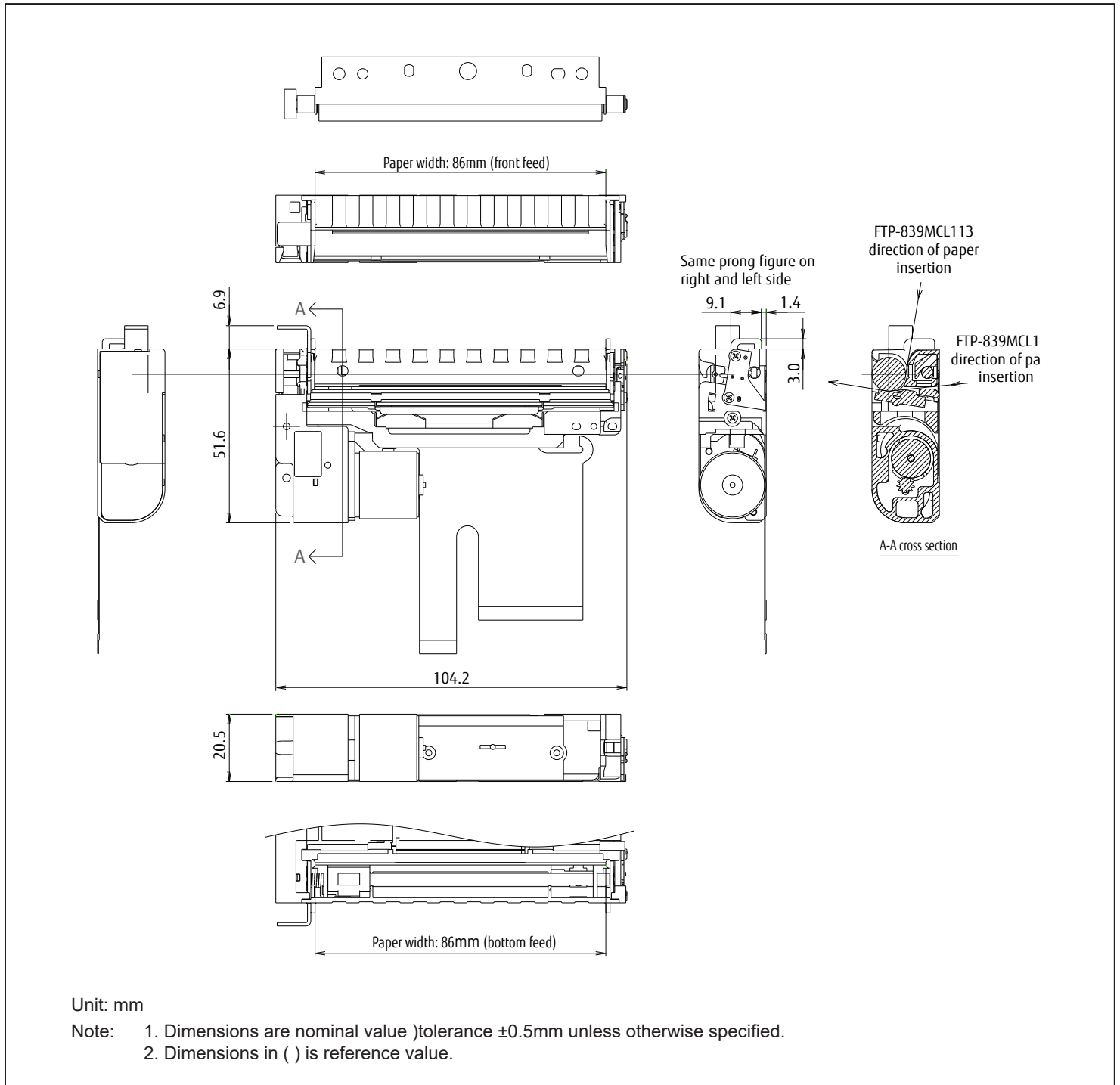

■ Connector pin assignments of printer mechanism (FPC)

No	Signal	Content
1	SW	Platen open switch
2	SW	Platen open switch
3	VH	+ 24 head drive power
4	VH	+ 24 head drive power
5	VH	+ 24 head drive power
6	Vsf*1	+ 24 head drive power
7	DI2	Data in 2
8	DO2	Data out 2
9	GND	Head ground
10	GND	Head ground
11	GND	Head ground
12	GND	Head ground
13	STB2	Strobe2
14	TM	Thermistor
15	TM	Thermistor
16	Vdd	+5V logic power
17	/LAT	Data latch
18	CLK	Clock
19	STB1	Strobe1
20	GND	Head ground
21	GND	Head ground
22	GND	Head ground
23	GND	Head ground
24	GND	Head ground
25	DI1	Data in 1
26	DO1	Data out 1
27	VH	+ 24 head drive power
28	VH	+ 24 head drive power
29	VH	+ 24 head drive power
30	VH	+ 24 head drive power
31	N.C.	Not connected
32	TM	Motor thermistor
33	TM	Motor thermistor
34	MT/A	Excitation signal /A
35	MT A	Excitation signal A
36	MT/B	Excitation signal /B
37	MT B	Excitation signal B
38	PHK	Cathode for photo interrupter
39	VSEN	Paper sensor power
40	PHE	Emitter for photo interrupter

**Contact**

**MEIKO ELECTRONIC COMPONENTS CO., LTD.**

935, Nosakada, Oaza, Iiyama-shi,  
Nagano, 389-2233, Japan  
Tel: (81-3) 0269-62-1155

---

**Copyright**

All trademarks or registered trademarks are the property of their respective owners. Meiko Electronic Components Co., Ltd. does not warrant that the content of datasheet is error free. In a continuing effort to improve our products Meiko Electronic Components Co., Ltd. reserves the right to change specifications/datasheets without prior notice.

Copyright ©2026 Meiko Electronic Components Co.,Ltd. All rights reserved. Revised June 1, 2026.

---