

DISCONTINUED

FCL Components Thermal Printer FTP-62DDSL001 series Interface Board

FCL Components interface board for low voltage printer mechanisms

Features

- Interface board for FTP-60D thermal printer mechanisms
- RS232C (max. 230,400bps) and USB (full speed) interface
- Various detection functions: paper, mark, thermal head temperature, power supply voltage, etc.
- Alphanumeric barcode printing available
- UL File No. E171434
- RoHS compliant

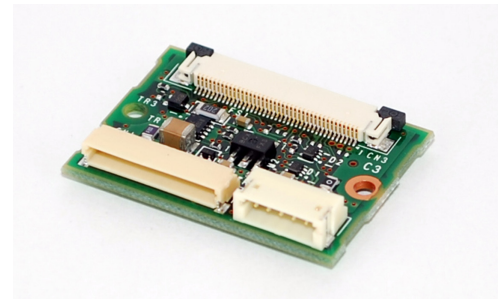

FTP-62DDSL001

■ Part numbers

Part number	Interface type	Length	Max. printing speed	Mechanism part numbers
FTP-62DDSL001	USB/RS232C	2-inch	100mm/sec.	FTP-62DMCL101#02 FTP-62DMCL111#02

■ Font

Font	Alphanumeric, Kana: 159, International: 195			
Dot structure	8 x 16 dots, 12 x 24 dots			

■ Barcode and image

Barcode	1D	UPC-A, UPC-E, JAN(EAN)13, JAN(EAN)8, CODE39, ITF, CODABAR, CODE128		
Bit image	Horizontal: 8 to 384 dots, vertical 1 to 1023 dots			

■ Specifications

Item	Specifications
Dimension	33 x 24mm
Weight	Approx. 5g
Communication interface	RS-232C (max. 230,400bps) USB full speed (max. 12Mbps)

■ Print/paper feed specifications

Item	Specifications	Notes
Dot pitch	0.125mm (H) x 0.125mm (W)	
Number of dots	384 dots	
Max. print width	48mm	
Line space	Approx. 1/8 inch (26 dots/line)	Changeable by command
Print speed	Max. 100mm/s	White line may appear depending on printing pattern or division control when printing. Please evaluate in advance
Paper feed (/ATF)	Approx. 30mm/s	

■ Interface specifications at host side

Item	Specifications
USB Ver. 2.0	Data speed: Full speed (max. 12Mbps.) Differential input/output
RS-232C	Dataspeed: 9,600 / 19,200 / 38,400 / 115,200 / 230, 400 bps* Synchronous method: Asynchronous communication, full duplex Flow control: RTS (DTR)• CTS (DSR) signal or X ON / X OFF* Input/output level: RS-232C level

*: Settings changed by command

■ Dimensions

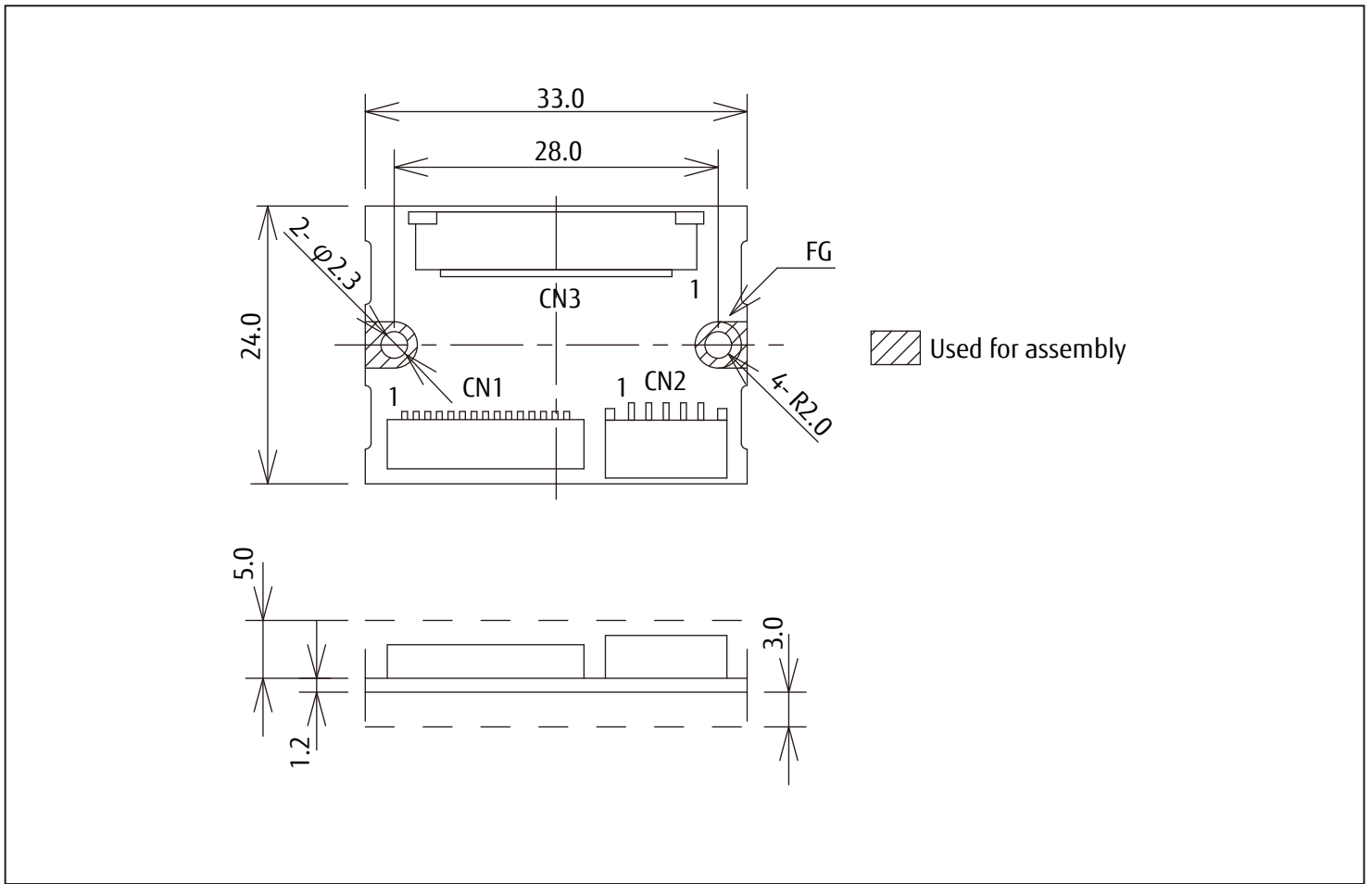

■ Connectors

Symbol	Name
CN1	Power supply and serial interface connector
CN2	USB connector
CN3	Printer mechanism connector

■ Connector for motor power supply, serial transmission

- Connector (CN1)
Recommended housing: SHR-15V-S (J.S.T.) or equivalent

No.	Signal	I/O	Content	No.	Signal	I/O	Content
1	V _p	I	Power input	2	V _p	I	Power input
3	V _p	I	Power input	4	V _p	I	Power input
5	GND	-	Head ground	6	GND	-	Head ground
7	GND	-	Head ground	8	GND	-	Head ground
9	RXD	I	Receive data	10	TXD	O	Transmit data
11	RTS (DTR)	O	Request to send	12	CTS (DSR)	I	Clear to send
13	/SLCTIN	I	Detection function disabled signal	14	/INPRM	I	Initialization signal
15	/ATF	I	Paper feed				

■ USB connector

- Connector (CN2)
Recommended housing: ZHR-5 (J.S.T.) or equivalent

No.	Signal	I/O	Content	No.	Signal	I/O	Content
1	Vbus	I	Bus power supply	2	D-	I/O	Differential data -
3	D+	I/O	Differential data +	4	FG	-	Frame ground
5	GND	-	Signal ground				

Note: Symbol “-” means a negative logic signal.
“I” or “O” means a signal direction from the interface board side

■ Connector for printer mechanism

- Connector (CN3)
Please refer to the printer mechanism specifications.

■ Commands

Command	Content
HT	Moves print position
LF	Line feed
FF	Feeds forms (new page)* ¹
DC2	Power down
ESC RS	Sets reverse printing
ESC US	Resets reverse printing
ESC SP+n	Character spacing setting
ESC !+n	Sets print mode
ESC *+m+nL+nH+d1~dk	Prints bit image
ESC -n	Undeline setting
ESC 2	Sets default line spacing
ESC 3+n	Sets the line feed length
ESC @	Printer initialization
ESC A+n	Set the space between the line
ESC C+n	Sets the page length by character line
ESC D+n1~nk+NUL	Set the tab position
ESC J+n	Feeds paper in forward direction and prints
ESC R+n	Selects international character
ESC V+n	Right rotation 90° specification/cancellation
ESC X+m+n	Setting the turning time of the motor excitation* ²
ESC a+n	Position alignment
ESC c+1+n	Sets internal processing
ESC c+5+n	External input signal valid/invalid setting* ³
ESC d+n	Printing and n-line feeding
ESC s+n	Sets printing speed* ⁴
ESC t+n	Character code table selection
ESC {+n	Sets/resets upside down printing
FS 9+n	Sets the detection functions
FS E+n	Correction of impressed energy
FS r+n	Parameter transmission (serial mode)
GS !+n	Character size setting
GS (EL1+L2+fn+d1~d9(fn=67)	RS-232C communication setting* ⁵
GS (K+pL+pH+fn	Print control setting
GS (K+pL+pH+fn+n (fn=49)	Print density setting
GS (K+pL+pH+fn+n (fn=50)	Print speed setting* ⁶
GS (K+pL+pH+fn+n (fn=97)	Macro definition start/end* ⁷
GS <	Line feeds to the next mark
GS A+m+n	Sets the line feed length after mark detection
GS E+n	Sets print quality
GS L+nL+nH	Sets left margin

■ Commands

Command	Content
GS W+nL+nH	Sets print area width
GS a+n	Sets automatic status transmission
GS e+m+n	Sets bar code width
GS h+n	Sets bar code height
GS k+m+n+d1~dn	Bar code print
GS w+n	Barcode horizontal size setting

*1: This product does not support labels and cut sheets as described in the command specification.

*2: This product will be "1-phase excitation" instead of "Small current excitation"

*3: This product does not support labels and cut sheets. Automatic paper feed function is described in the command specification. Please use the default value (continuous forms).

*4: This product does not support speed mode 6 to 15 as described in the command specification. Please use in the range of speed mode 1 to 5.

*5: This product does not support 460.8kbps as described in the command specification. Please use in the range of 9.6kbps to 230.4kbps.

This command writes to the flash memory by parameters. Please see command specification.

*6: The relationship between Speed level and Print speed is shown in the table below.

Speed level	Print speed	Speed level	Print speed	Speed level	Print speed	Speed level	Print speed
Level 1	Not used	Level 4	12.5mm/s	Level 7	40mm/s	Level 10	80mm/s
Level 2	Not used	Level 5	15mm/s	Level 8	50mm/s	Level 11	100mm/s
Level 3	Not used	Level 6	25mm/s	Level 9	60mm/s	Level 12	Not used

*7: The relationship between head division and simultaneous energizing dots is shown below.

Simultaneous energizing dots = Number of line dots / number of head division

(E.g. Number of line dots: 384 dots Number of head division: 4 Simultaneous energizing dots: 384 dots / 4= 94 dots)

■ Options

Item	Part number	Connector	Length
USB interface cable	FTP-62GY301	USB-A plug and ZHR-5 (J.S.T.)	1m

Contact

Japan

FCL COMPONENTS LIMITED
Shinagawa Seaside Park Tower
12-4, Higashi-shinagawa 4-chome,
Tokyo 140 0002, Japan
Tel: +81 3 3450 1682
Email: fcl-contact@cs.fcl-components.com

Europe

FCL COMPONENTS EUROPE B.V.
Diamantlaan 25
2132 WV Hoofddorp
Netherlands
Tel: +31 23 5560910
Email: info@fcl-components.eu

China

FCL COMPONENTS (SHANGHAI) CO., LTD.
Unit 1105, Central Park –Jing An, No.329 Heng Feng
Road, Shanghai 200070, China
Tel: +86 021 3253 0998
Email: fcsh@fcl-components.com

North and South America

FCL COMPONENTS AMERICA, INC.
2055 Gateway Place, Suite 480
San Jose, CA 95110 U.S.A.
Tel: +1 408 745 4900
Email: contact@fcl-components.us

Asia Pacific

FCL COMPONENTS ASIA, LTD.
51 Changi Business Park Central, #06-07
Singapore 486066
Tel: +65 6375 8560
Email: fcal@fcl-components.com

Hong Kong

FCL COMPONENTS HONG KONG Co., LIMITED
Room 13, 23/F, Seapower Tower, Concordia Plaza,
No.1 Science Museum Road,
Tsim Sha Tsui East, Kowloon, Hong Kong
Tel: +852 2881 8495
Email: fcsh@fcl-components.com

Web: www.fcl-components.com/en/

Copyright

All trademarks or registered trademarks are the property of their respective owners. FCL Components America or its affiliates do not warrant that the content of datasheet is error free. In a continuing effort to improve our products FCL Components America, Inc. or its affiliates reserve the right to change specifications/datasheets without prior notice.

Copyright ©2026 FCL Components America, Inc. All rights reserved. Revised February 16, 2026.