



TuffDrive® eUSB – USB 3.1 Gen 1 High Speed SSD

Industrial eUSB Module, 10 Pin Low Profile, pSLC

VTDU42XI008G-V11

Datasheet - Rev. 1.1

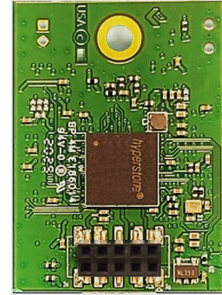

1. Description

Virtium TuffDrive eUSB SSDs are ideal solutions for server, networking, embedded and industrial applications that require a modest amount of storage and require a widely supported USB 3.1 Gen 1 interface. Typical applications include operating system and file storage, system level diagnostics, or as a backup repository for data in DRAM in the event of a system-level power-down.

Features

Capacity

- 8 GB

pSLC NAND

Performance

- Sequential Read: 180 MB/s
- Sequential Write: 40 MB/s

Voltage Supply: 5V \pm 5% or 3.3V \pm 5%

Power Consumption⁽¹⁾

- Sequential Read: 1.12 W
- Sequential Write: 1.06 W
- Idle: 0.23 W

Temperature Ranges

- Industrial: -40°C to 85°C
- Non-Operating: -40°C to 85°C

Reliability

- Flexible 96-Bit/1K BCH ECC
- MTBF: >5M hours

Endurance

- JESD219A: 20.03 TBW
- Sequential: 198.74 TBW

SMART Attribute Reporting

- Monitors device health
- Anticipates and predicts failures

Mechanical Dimensions

- Horizontal Mount, 2.00mm Pin-Pitch Connector
- Length x Width x Height mm (inches)
36.90 (1.553) x 26.60 (1.047) x 6.00 (0.236)

Compliance

- USB 3.1 Gen 1
- FCC, CE, UL, RoHS, WEEE

Environmental (Non-operating)

- Humidity (non-condensing): 5% to 95%
- Shock: 1500G, half-sine wave, 0.5ms duration
- Vibration: 20G, 20 Hz to 2000 Hz

(1) Based on a 5.0V power supply



Electrostatic Discharge (ESD) can damage this device. When handling the device, always wear a grounded wrist strap and use a static dissipative surface.



Any damage to the unit that occurs after its removal from the shipping package and ESD protective bag is the responsibility of the user.

Part Numbering System

V TD U42 X I 008G - V11

Where:	
V	= Virtium
TD	= TuffDrive
U42	= Form Factor / Interface: U42 = USB 3.1 Gen 1, 10-Pin, 2.00mm Pitch Connector
X	= Product Class: X = XE
I	= Operating Temperature: I = Industrial (-40°C to 85°C)
008G	= 8GB (1GB = 1,000,000,000 bytes)
V11	= Virtium Proprietary

2. Specifications

Capacity

Unformatted Capacity (GB) ⁽¹⁾	User-Addressable LBA ⁽²⁾	User-Addressable Capacity Bytes
8	15,630,680	8,002,908,160
(1) 1GB = 1,000,000,000 bytes. LBA: Logical Block Address; Logical Block Size = 512 Bytes/1 Sector.		
(2) LBA: Logical Block Address; Logical Block Size = 512 Bytes/1 Sector.		

Performance

Capacity (GB)	Sequential Read ⁽¹⁾ (MB/s)	Sequential Write ⁽¹⁾ (MB/s)
8	180	40
(1) CrystalDiskMark 7.0.0		

Power Requirements

Parameter	Min	Typ	Max
Voltage supply 5V (±5%)	4.75V	5.0V	5.25V
Voltage supply 3.3V (±5%)	3.14V	3.3V	3.47V

Parameter	Sequential Read	Sequential Write	Idle
Power Consumption ⁽¹⁾	1.12 W	1.06 W	0.23 W
(1) Based on 100% Sequential Read / Write, 64K, 70/30 read/write workload @ 5.0V.			

Temperature and Humidity

Part Number	Operating Temperature	Non-Operating ⁽¹⁾ Temperature	Humidity (Non-Condensing)
VTDU42XI008G-V11	-40°C to 85°C	-40°C to 85°C	5% to 95%
(1) Maximum non-operating temperature assumes data is stored on the SSD. Temperatures above 85°C are beyond NAND specification for data retention. Please see <i>Temperature Considerations for Industrial Embedded SSDs</i> whitepaper under the industrial SSD section of Virtium website (Virtium.com)			

Shock and Vibration

Reliability	Test Conditions	Reference Standards
Shock	1500G, half-sine wave, 0.5ms duration	JESD22-B110B.01
Vibration	20G, 20 Hz to 2000 Hz	JESD22-B103B.01

3. Reliability

Endurance

Capacity (GB)	JESD218A ⁽¹⁾ & JESD219 Enterprise Workloads		100% Sequential Workloads	
	Total Bytes Written TBW (TB)	Drive Writes per day (5 years)	Total Bytes Written TBW (TB)	Drive Writes per day (5 years)
8	20.03	1.37	198.74	13.60
(1) JESD218A assumes an active temperature at 55°C and a retention temperature at 40°C				

Mean Time Between Failures (MTBF)

The SSD achieves a MTBF of greater than 5,000,000 hours predicted and is derived from the component reliability data using Telcordia SR-332 methods at 40°C and tested under standard environmental operating conditions.

4. Physical Specifications

Pin Layout / Assignments

Socket Pinout		Pin Assignments	
		Pin No.	Assignment
9		1	V_Bus Operating voltage
7		2	USB3 SSRX+ USB 3.0 signal receiving line
5		3	D- Data signal pair
3		4	USB3 SSRX- USB 3.0 signal receiving line
1		5	D+ Data signal pair
		6	GND Ground
		7	GND Ground
		8	USB3 SSTX+ USB 3.0 signal transmission line
		9	KEY Keyed at connector (No connect)
		10	USB3 SSTX- USB 3.0 signal transmission line

Mechanical Dimensions

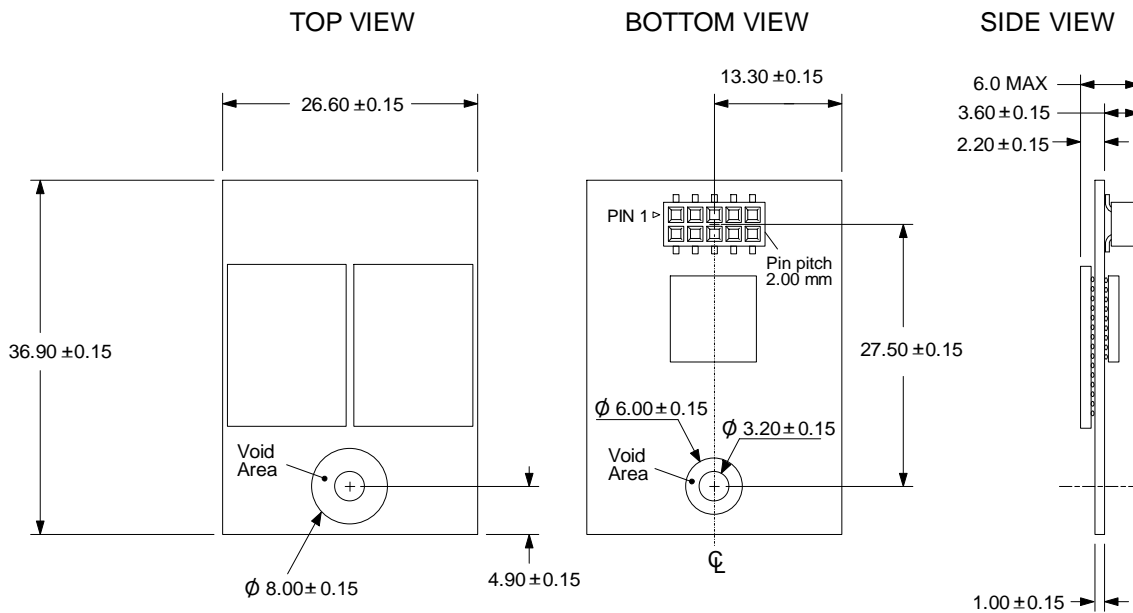

- Note:
1. All dimensions are in millimeters
 2. The dimensional diagram is for reference only

5. SMART Attributes

Introduction

The following table defines the current SMART data attributes that are supported.

Attribute ID (Hex)	Attribute ID (Dec)	Attribute Name	Description
0x0C	12	Power Cycle Count	Number of Power On Cycles
0xC2	194	Temperature	Not used.
0xC4	196	Spare Block Count	The amount of available spare blocks. The attribute value returned is the percentage of remaining spare blocks summed over all flash chips, i.e., $(100 \times \text{Current Spare Blocks} / \text{Initial Spare Blocks})$.
0xC7	199	UDMA CRC Error Rate	Not used but included for compatibility.
0xCB	203	ECC Error Count	Total number of ECC errors correctable and uncorrectable for the NAND data.
0xCC	204	Number of Corrected ECC Errors	The total number of correctable ECC errors that have occurred on flash read commands.
0xD5	213	Reserved	Reserved
0xD6	214	Reserved	Reserved
0xE5	229	Erase Count	The value returned is an estimation of the remaining card life, expressed as a percentage according to the number of flash block erases compared to the target number of erase cycles per block.
0xE8	232	Number of Reads	The total number of flash read commands.
0xF1	241	Total LBAs Written	Total number of LBAs written to the disk, divided by 65536.
0xF2	242	Total LBAs Read	Total number of LBAs read from the disk, divided by 65536.

6. Certifications and Compliance

Compliance / Certification	Description
CE and FCC Compliant	Class: FCC Part 15 Subpart B Class B:2011 Declaration of Conformity registration No. STE120607699
RoHS Compliant	Restriction of Hazardous Substance Directive
UL Certified	Underwriters Laboratories, Inc. 94V-0
WEEE Certified	Waste, Electrical and Electronic Equipment Directive
ISO-9001 AS9001 Rev. C Certificate	Quality Management
ISO-14001 Certificate	Environmental Management

7. Contact Information

Corporate Headquarters and Manufacturing Location:
30052 Tomas, Rancho Santa Margarita, CA 92688 USA

Main Website: www.virtium.com
Contacts / Sales: <http://www.virtium.com/contacts-sales/>
Toll Free: (888) VIRTUUM / (888) 847.8486
Telephone: 1+ (949) 888.2444
Fax: +1 (949) 888.2445
Customer Support custserv@virtium.com

8. Revision History

Date	Revision	Page(s)	Description
01/21/2021	1.0	All	Initial release
07/20/2021	1.1	1, 3	Change the title to "Industrial eUSB Module, 10 Pin Low Profile, pSLC" Update product images Add Endurance table



Virtium manufactures storage and memory and solutions for the world's foremost industrial embedded OEMs. For over two decades, we have designed, manufactured and supported our products in the USA – fortified by a network of global locations. Our world-class technology and unsurpassed support provide a superior customer experience that continuously results in better industrial embedded products for an increasingly interconnected world.

© Copyright 2021. All rights reserved. Virtium®, StorFly®, TuffDrive®, StorKit®, vtView®, vtGuard® are registered trademarks and, vtSecure™ and vtTools™ are trademarks of Virtium LLC. All other non-Virtium product names are trademarks of their respective companies.