



CFM61S SERIES 60 WATT OPEN FRAME AC-DC MODULES

Features

- Universal Input Range 90~264Vac
- High Efficiency up to 90%
- 2"x 2" Compact Size
- Class II
- No Load Input Power Consumption < 0.15W
- Approved IEC/EN/UL 62368-1 Ed 3.0
- Approved EN 55032 and CISPR/FCC Class B
- Continuous Short Circuit Protection
- Over Voltage Protection
- Peak Load (2 Times of Rated Current (Note7))



MODEL NUMBER	OUTPUT VOLTAGE	OUTPUT CURRENT	VOLTAGE ACCURACY NOTE1	RIPPLE & NOISE NOTE2	LINE REGULATION NOTE3	LOAD REGULATION NOTE4	%EFF. (Typ.) NOTE5
CFM61S050	5 V	8 A	2%	50 mV	±1%	±1%	86%
CFM61S120	12 V	5 A	1%	120 mV	±1%	±1%	88%
CFM61S150	15 V	4 A	1%	150 mV	±1%	±1%	88%
CFM61S240	24 V	2.5 A	1%	240 mV	±1%	±1%	89%
CFM61S360	36 V	1.67 A	1%	360 mV	±1%	±1%	89%
CFM61S480	48 V	1.25 A	1%	480 mV	±1%	±1%	90%

Note:

1. Voltage accuracy is set at 100% full load.
2. Add a 0.1uF ceramic capacitor and a 10uF E.L. capacitor to output for ripple & noise measuring @20MHz BW.
(CFM61S050: Add a 0.1uF ceramic capacitor and a 47uF E.L. capacitor to output for ripple & noise measuring @20MHz BW.)
3. Line regulation is measured from 0V_{ac} to 264V_{ac} with 100% full load.
4. Load regulation measured from 10% to 100% full load.
5. Typical efficiency at 230 Vac and 75% full load at 25°C.
6. Standard input and output connectors (CN1 and CN2) wafer with TAIWAN KING PIN TERMINAL PVHI series and mate with JST housing VHR series or equivalent.
7. PL (Peak load function) Lasting time < 10 seconds with a maximum 10% duty cycle and must add external 100uF / 400V capacitor to BC+ & BC-.

PART NUMBER

Series	Number of Outputs	Nominal Output Voltage	Type	Type
CFM61	O	XXX	-X	YZ (Option)
CFM61	S : Single	050 : 5V 120 : 12V 150 : 15V 240 : 24V 360 : 36V 480 : 48V	Blank : PCB Mount E : Encapsulated T : Wafer (without PL)	Blank PL : Peak Load Function

Part Number Example:

- CFM61S120-E: Encapsulated, Single 12Vdc Output
- CFM61S120-E PL: Encapsulated, With PL, Single 12Vdc Output



CFM61S Series

TECHNICAL SPECIFICATIONS

(All specifications are typical at nominal input, full load at 25°C unless otherwise noted.)

ABSOLUTE MAXIMUM RATINGS

PARAMETER	NOTES and CONDITIONS	Device	Min.	Typ.	Max.	Units
Input Voltage	Safety approvals only to the AC input	All	90		264	V _{ac}
			120		370	V _{dc}
Operating Temperature	See derating curve	All	-30		80	°C
Storage Temperature		All	-30		85	°C
Operating Altitude		All			5000	m

INPUT CHARACTERISTICS

PARAMETER	NOTES and CONDITIONS	Device	Min.	Typ.	Max.	Units
Operating Voltage Range		All	100		240	V _{ac}
Input Frequency Range		All	50		60	Hz
Maximum Input Current	100% Load, V _{in} =100V _{ac}	All			1.5	A
Inrush Current	V _{in} =240V _{ac} , Cold Start @25°C	All			120	A
Leakage Current (Touch)		All			0.25	mA

OUTPUT CHARACTERISTICS

PARAMETER	NOTES and CONDITIONS	Device	Min.	Typ.	Max.	Units
Output Voltage Set Point	V _{in} =90V _{ac} ~264V _{ac} , I _o =I _o max., ambient temperature=25°C	CFM61S050	4.9	5	5.1	V _{dc}
		CFM61S120	11.88	12	12.12	
		CFM61S150	14.85	15	15.15	
		CFM61S240	23.76	24	24.24	
		CFM61S360	35.64	36	36.36	
		CFM61S480	47.52	48	48.48	
Operating Output Current Range	V _{in} =90V _{ac} ~264V _{ac} , see derating curve	CFM61S050	0		8	A
		CFM61S120	0		5	
		CFM61S150	0		4	
		CFM61S240	0		2.5	
		CFM61S360	0		1.67	
		CFM61S480	0		1.25	
Holdup Time	V _{in} =115V _{ac}	All		10		ms
Output Voltage Regulation						
Load Regulation	10% Load to full load	All			±1.0	%
Line Regulation	V _{in} =High line to low line	All			±1.0	%
Over Voltage Protection	Clamp output voltage	CFM61S050		6.8		V _{dc}
		CFM61S120		15		
		CFM61S150		18		
		CFM61S240		30		
		CFM61S360		47		
		CFM61S480		56		
Output Ripple and Noise	1. Add a 0.1uF ceramic capacitor and a 10uF aluminum electrolytic capacitor to output. (CFM61S050: Add a 0.1uF ceramic capacitor and 47uF aluminum electrolytic capacitor to output.) 2. Oscilloscope is 20MHz band width 3. Ambient temperature=25°C	CFM61S050			50	mV
		CFM61S120			120	
		CFM61S150			150	
		CFM61S240			240	
		CFM61S360			360	
		CFM61S480			480	



CFM61S Series

PARAMETER	NOTES and CONDITIONS	Device	Min.	Typ.	Max.	Units
Short Circuit Protection	Auto recovery	All				
Load Capacitance	1. Input voltage is 115V _{ac} and 230V _{ac} 2. Output is 100% full load 3. Ambient temperature=25°C	CFM61S050 CFM61S120 CFM61S150 CFM61S240 CFM61S360 CFM61S480			8000 5000 4000 2400 1680 680	uF
Efficiency	1. Input voltage is 230V _{ac} . 2. Output is 75% full load 3. Ambient temperature=25°C	CFM61S050 CFM61S120 CFM61S150 CFM61S240 CFM61S360 CFM61S480		86 88 88 89 89 90		%

ISOLATION CHARACTERISTICS

PARAMETER	NOTES and CONDITIONS	Device	Min.	Typ.	Max.	Units
Input to Output	1 Minute (without dielectric breakdown)	All			3000	V _{ac}
Isolation Resistance	Input to output	All	100			MΩ

FEATURE CHARACTERISTICS

PARAMETER	NOTES and CONDITIONS	Device	Min.	Typ.	Max.	Units
Switching Frequency		All		65		kHz

GENERAL CHARACTERISTICS

PARAMETER	NOTES and CONDITIONS	Device	Min.	Typ.	Max.	Units
MTBF	I _o =100%; T _a =25°C per MIL-HDBK-217F I _o =100%, T _a =25°C, Telcordia SR332	All	365 2930			k hours
Life Time	@75% Load, 40°C	All	26			k hours
Humidity	Non-condensing	All			93	% RH
Shock	Meets MIL-STD-810F Table 516.5, TABLE 516.5- I 10ms, each axis 3 times(±X · ±Y · ±Z axis)	All		75		g
Vibration	Meets MIL-STD-810F Table 514.5C-VIII, 15~2000Hz, X · Y · Z axis, 1 hrs(each axis),. total 3 hrs	All		4		g
Weight		CFM61SXXX CFM61SXXX-E CFM61SXXX-T		93 190 96		grams
Dimension		CFM61SXXX CFM61SXXX-E CFM61SXXX-T	2.00x2.00x1.398 Inches (50.8x50.8x35.50 mm) 2.14x2.14x1.409 Inches (54.3x54.3x35.80 mm) 2.70x2.00x1.343 Inches (68.6x50.8x34.10 mm)			
Safety	Class II, IEC/EN/UL 62368-1					Ed. 3.0
EMC Emission	EN 55032, EN 61000-3-2, EN 6100-3-3, EN 61000-6-3, EN 61000-6-4, 47 CFR FCC Part 15, ICES-003 Issue 7					Class B
Conducted Disturbance	EN 55032, EN 61000-6-3, 47 CFR FCC Part 15					Class B
Radiated Disturbance	EN 55032 EN 61000-6-3, 47 CFR FCC Part 15					Class B
Harmonic Current Emissions	EN 61000-3-2					Class A
Voltage Fluctuations & Flicker	EN 61000-3-3					Criterion A
EMC Immunity	EN 55035, EN 61204-3, EN 61000-6-1, EN 61000-6-2					Criterion A
Electrostatic Discharge (ESD)	IEC 61000-4-2, Level 3 Air discharge: ±8kV, Level 2 Contact discharge: ±4kV					Criterion A



CFM61S Series

GENERAL CHARACTERISTICS

Radio-Frequency, Continuous Radiated Disturbance	IEC 61000-4-3, Level 3: 80~1000MHz, 10V/m	Criterion A
Electrical Fast Transient (EFT)	IEC 61000-4-4, Level 3: ± 2 KV	Criterion A
Surge	IEC 61000-4-5, Level 3: L-N: ± 1 kV	Criterion A
Conducted Disturbances, Induced by RF Fields	IEC 61000-4-6, Level 3: 0.15~80MHz, 10V	Criterion A
Power Frequency Magnetic Field	IEC 61000-4-8, Level 4: 30A/m	Criterion A
Voltage Dips	IEC 61000-4-11, Dip: 30% IEC 61000-4-11, Dip: >95%	Criterion A
Voltage Interruptions	IEC 61000-4-11, >95% 5000ms	Criterion B
Application Note Link	CFM61S Series App Notes	

CHARACTERISTIC CURVE

Power Derating Curve

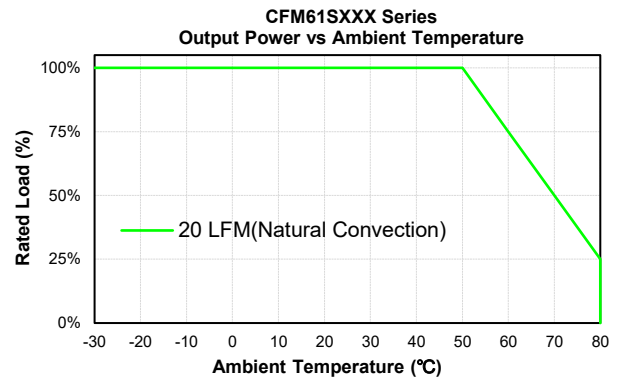
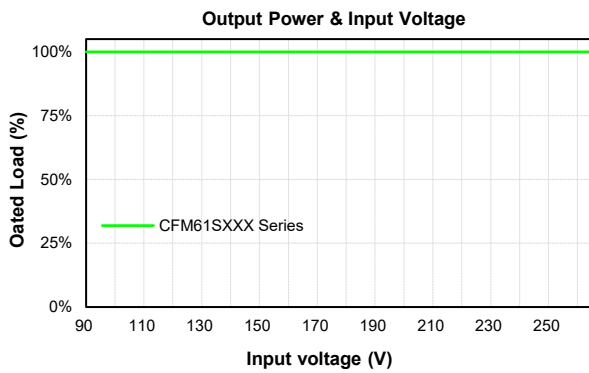

Performance Data

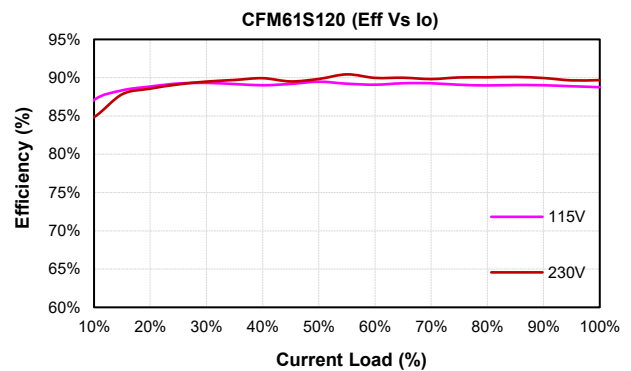
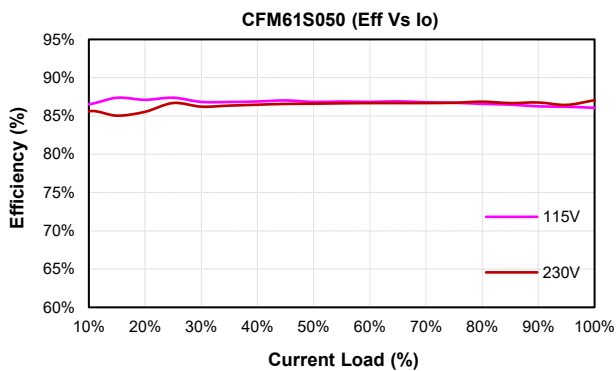



CFM61S Series

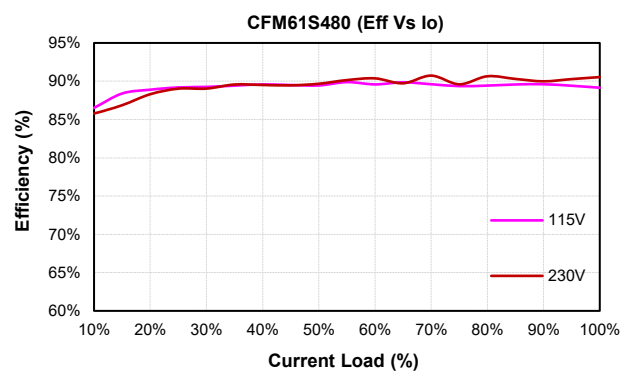
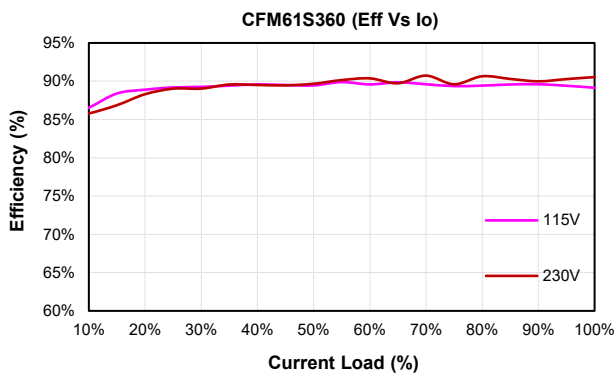
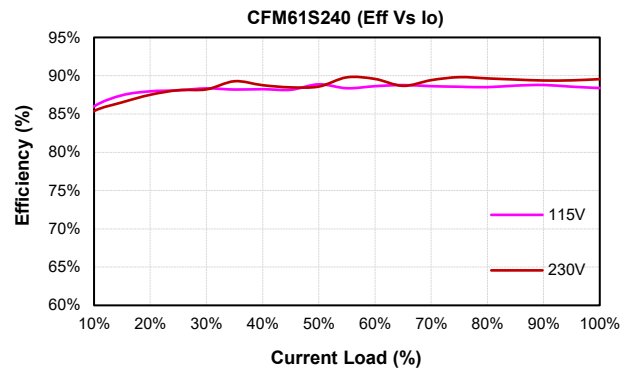
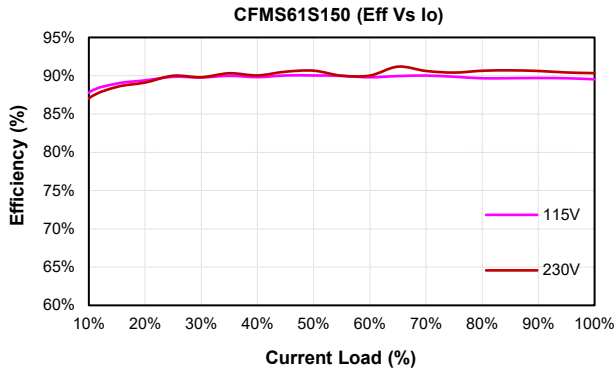



CFM61S Series

MECHANICAL SPECIFICATION

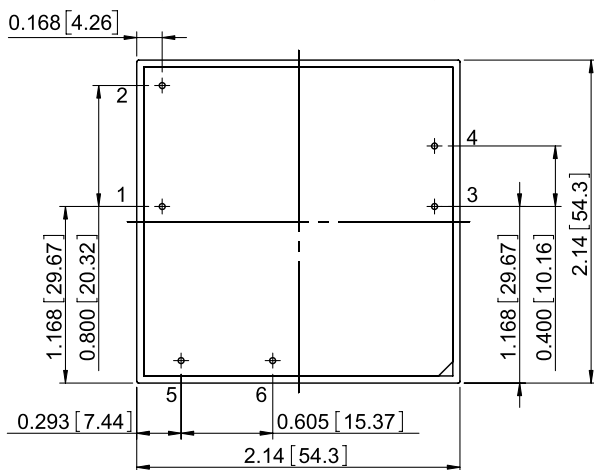
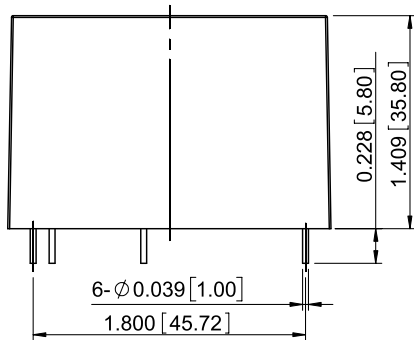
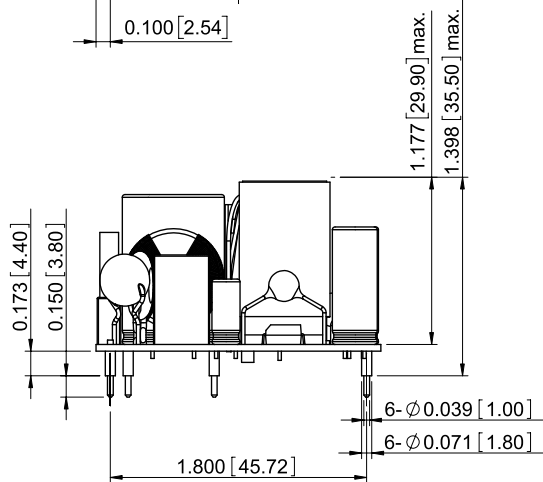
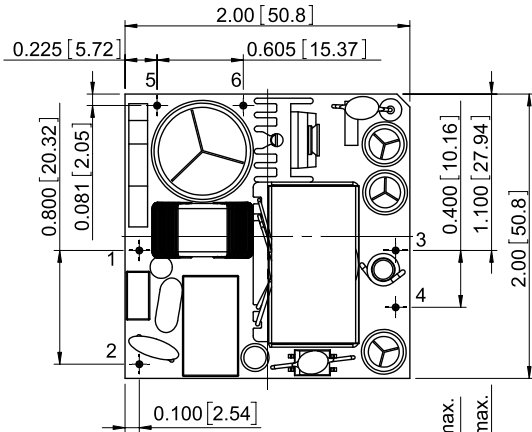

BOTTOM VIEW

CFM61SXXX

All Dimensions in Inches[mm]

Tolerance Inches: x.xx=±0.03, x.xxx=±0.020

Millimeters: x.x=±0.7, x.xx=±0.50

Pin Connection

Pin	Function
1	ACL
2	ACN
3	+V Output
4	-V Output
5	BC+
6	BC-

CFM61SXXX-E

All Dimensions in Inches[mm]

Tolerance Inches: x.xx=±0.03, x.xxx=±0.020

Millimeters: x.x=±0.7, x.xx=±0.50

Pin Connection

Pin	Function
1	ACL
2	ACN
3	+V Output
4	-V Output
5	BC+
6	BC-



CFM61S Series

MECHANICAL SPECIFICATION

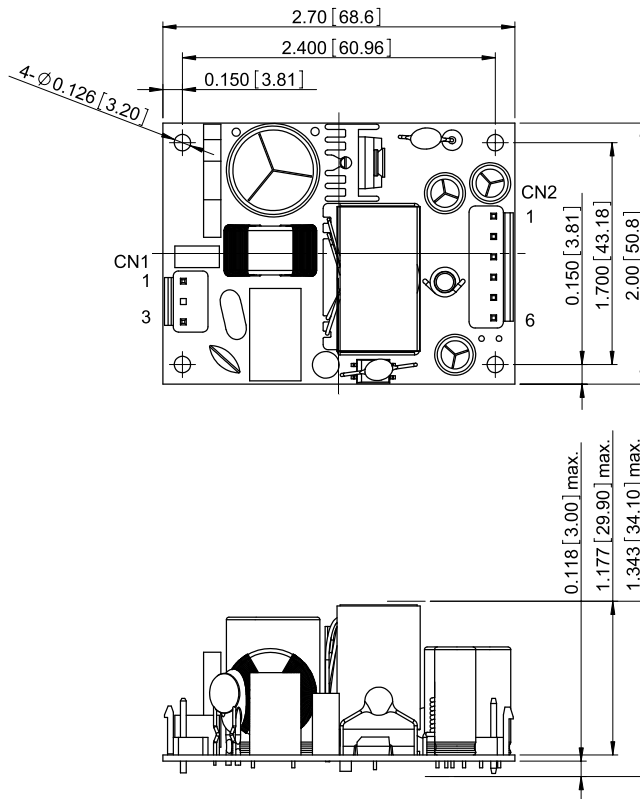

CFM61SXXX-T

All Dimensions in Inches[mm]
 Tolerance Inches: x.xx=±0.03, x.xxx=±0.020
 Millimeters: x.x=±0.7, x.xx=±0.50

AC Input Connector(CN1):TKP PVHI-03N2 or equivalent

Pin	Function	Mating Housing	Terminal
1	ACL	JST VHR-3N or equivalent	JST SVH-21T-P1.1 or equivalent
2	-		
3	ACN		

DC Output Connector(CN2):TKP PVHI-06 or equivalent

Pin	Function	Mating Housing	Terminal
1	+Vout	JST VHR-6N or equivalent	JST SVH-21T-P1.1 or equivalent
2	+Vout		
3	+Vout		
4	-Vout		
5	-Vout		
6	-Vout		

CINCON Electronics Co. Ltd.
 Add: 14F, No. 306, Sec.4, Hsin Yi Rd., Taipei, Taiwan
 Tel: 886-2-27086210
 Fax: 886-2-27029852
 E-mail: sales@cincon.com
 Web: www.cincon.com