

## XLamp® XP-L Color LEDs

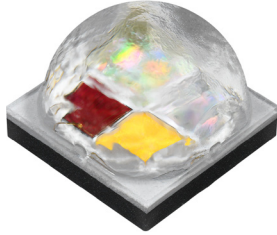

XP-L High Density Color

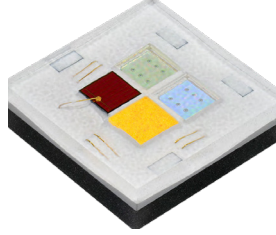

XP-L High Intensity Color - Blend

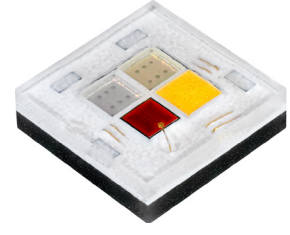

XP-L High Intensity Color - Saturation

### PRODUCT DESCRIPTION

XLamp® XP-L Color LEDs are multi-color RGBW LEDs that deliver the combination of high lumen output and great color mixing in a small 3.45 x 3.45 mm package. The XLamp XP-L Color LEDs feature the smallest possible distance between LED die, creating a small optical source for excellent optical control and efficient color mixing. The High Intensity version of this LED now has the RGB die available in two different configurations: Blend and Saturation. Blend places the green and phosphor-converted die diagonally to balance light output through secondary optics. Saturation places the blue and phosphor-converted die diagonally to reduce crosstalk and increase blue saturation.

XLamp XP-L Color LEDs are optimized for all high-performance RGBW lighting applications, including color-changing, stage, architectural and entertainment.

The XP-L Color LED offers high-density and high-intensity options. In this document, the term XP-L Color denotes the XP-L Color LED without regard to high density or high intensity. The terms High Density and High Intensity are used when necessary to differentiate the performance of the two options.

### FEATURES

- Available in red, green, blue and either white or amber in a single package
- Maximum drive current per LED die: 1 A
- Individually addressable LEDs
- Reflow solderable – JEDEC J-STD-020
- Electrically neutral thermal path
- RoHS and REACH compliant
- UL® recognized component (E349212)



Cree LED / 4001 E. Hwy. 54, Suite 2000 / Durham, NC 27713 USA / +1.919.313.5330 / [www.cree-led.com](http://www.cree-led.com)

**TABLE OF CONTENTS**

---

Characteristics - Complete Package ..... 3

Characteristics - Per LED Die..... 3

Flux Characteristics ..... 4

Relative Spectral Power Distribution ..... 7

Relative Flux vs Junction Temperature..... 8

Electrical Characteristics..... 8

Relative Flux vs. Current ..... 9

Typical Spatial Distribution..... 9

Bin and Order Code Formats ..... 10

Performance Groups – Luminous Flux..... 11

Performance Groups – Dominant Wavelength ..... 12

Performance Groups – Chromaticity..... 12

Performance Groups - Chromaticity Bins..... 16

Reflow Soldering Characteristics..... 17

Notes ..... 18

Mechanical Dimensions ..... 19

Tape and Reel..... 24

Packaging..... 28

## CHARACTERISTICS - COMPLETE PACKAGE

The following table lists the product characteristics for the XLamp XP-L Color LED package, measured with all LED dies on simultaneously and each LED die connected to independent drive circuits at 700 mA.

Characteristics	Unit	Minimum	Typical	Maximum
Thermal resistance, junction to solder point	°C/W		1.4	
Viewing angle (FWHM) - High Density	degrees (°)		110	
Viewing angle (FWHM) - High Intensity	degrees (°)		120	
ESD withstand voltage (HBM per Mil-Std-883D)			Class 3B	
LED junction temperature	°C			150

## CHARACTERISTICS - PER LED DIE

The following table lists the product characteristics for each LED die within the XLamp XP-L Color LED package.

Characteristics	Unit	Minimum	Typical	Maximum
Temperature coefficient of voltage - red	mV/°C		-1.79	
Temperature coefficient of voltage - green	mV/°C		-1.11	
Temperature coefficient of voltage - blue	mV/°C		-1.17	
Temperature coefficient of voltage - white	mV/°C		-1.18	
Temperature coefficient of voltage - PC amber	mV/°C		-1.14	
DC forward current - red, green, blue, white, PC amber	mA			1000
Forward voltage (@ 700 mA, 25 °C) - red	V		2.7	3.2
Forward voltage (@ 700 mA, 25 °C) - green	V		3.4	3.7
Forward voltage (@ 700 mA, 25 °C) - blue, white	V		3.3	3.6
Forward voltage (@ 700 mA, 25 °C) - PC amber	V		3.2	3.5

## FLUX CHARACTERISTICS (T<sub>J</sub> = 25 °C)

The following tables provide several base order codes for XP-L High Density Color LEDs. For a complete description of the order code nomenclature, please refer to the Bin and Order Code Formats section (page 16).

### High Density

Color		CCT / Dominant Wavelength Range		Minimum Luminous Flux @ 700 mA		Typical Luminous Flux @ 700 mA	Order Code
		Minimum	Maximum	Group	Flux (lm)	Flux (lm)	
Color + Cool White	Red	620 nm	630 nm	C6	95	145	XPLDCL-00-0000-0000HC6AAAE2
	Green	520 nm	535 nm		145	185	
	Blue	450 nm	465 nm		20	35	
	Cool White	5400 K	6000 K		140	205	
Color + Neutral White	Red	620 nm	630 nm	C6	95	145	XPLDCL-00-0000-0000HC6AAAE5
	Green	520 nm	535 nm		145	185	
	Blue	450 nm	465 nm		20	35	
	Neutral White	3700 K	4300 K		140	195	
Color + Warm White	Red	620 nm	630 nm	C6	95	145	XPLDCL-00-0000-0000HC6AAAE7
	Green	520 nm	535 nm		145	185	
	Blue	450 nm	465 nm		20	35	
	Warm White	2700 K	3300 K		140	185	

**Notes:**

- XLamp XP-L Color LED order codes specify only a minimum flux bin and not a maximum. Cree LED may ship reels in flux bins higher than the minimum specified by the order code without advance notice. Shipments will always adhere to the chromaticity or DWL bin restrictions specified by the order code.
- Cree LED maintains a tolerance of ±7% on flux and power measurements, ±0.005 on chromaticity (CCx, CCy) measurements and ±1 nm on dominant wavelength measurements. See the Measurements section (page 18).
- Flux and chromaticity are measured with each LED die connected to independent drive circuits at 700 mA. The flux and chromaticity of each LED die within the XLamp XP-L Color LED package are measured individually.

**FLUX CHARACTERISTICS (T<sub>J</sub> = 25 °C) - CONTINUED**

The following tables provide several base order codes for XP-L High Intensity Blend Color LEDs. For a complete description of the order code nomenclature, please refer to the Bin and Order Code Formats section (page 16).

**High Intensity - Blend**

Color		CCT / Dominant Wavelength Range		Minimum Luminous Flux @ 700 mA		Typical Luminous Flux @ 700 mA	Order Code
		Minimum	Maximum	Group	Flux (lm)	Flux (lm)	
Color + Cool White	Red	620 nm	630 nm	A3	85	110	XPLDCL-H0-0000-0000HA3AAAE2
	Green	520 nm	535 nm		120	135	
	Blue	450 nm	465 nm		20	27	
	Cool White	5400 K	6000 K		160	175	
Color + Neutral White	Red	620 nm	630 nm	A3	85	110	XPLDCL-H0-0000-0000HA3AAAE5
	Green	520 nm	535 nm		120	135	
	Blue	450 nm	465 nm		20	27	
	Neutral White	3700 K	4300 K		160	170	
Color + Warm White	Red	620 nm	630 nm	A2	85	110	XPLDCL-H0-0000-0000HA2AAAE7
	Green	520 nm	535 nm		120	135	
	Blue	450 nm	465 nm		20	27	
	Warm White	2700 K	3300 K		120	165	

**Notes:**

- XLamp XP-L Color LED order codes specify only a minimum flux bin and not a maximum. Cree LED may ship reels in flux bins higher than the minimum specified by the order code without advance notice. Shipments will always adhere to the chromaticity or DWL bin restrictions specified by the order code.
- Cree LED maintains a tolerance of ±7% on flux and power measurements, ±0.005 on chromaticity (CCx, CCy) measurements and ±1 nm on dominant wavelength measurements. See the Measurements section (page 18).
- Flux and chromaticity are measured with each LED die connected to independent drive circuits at 700 mA. The flux and chromaticity of each LED die within the XLamp XP-L Color LED package are measured individually.

**FLUX CHARACTERISTICS (T<sub>J</sub> = 25 °C) - CONTINUED**

The following tables provide several base order codes for XP-L High Intensity Saturation Color LEDs. For a complete description of the order code nomenclature, please refer to the Bin and Order Code Formats section (page 16).

**High Intensity - Saturation**

Color		CCT / Dominant Wavelength Range		Minimum Luminous Flux @ 700 mA		Typical Luminous Flux @ 700 mA	Order Code
		Minimum	Maximum	Group	Flux (lm)	Flux (lm)	
Color + Cool White	Red	620 nm	630 nm	A3	85	110	XPLDCL-H0-0000-000SHA3AAAE2
	Green	520 nm	535 nm		120	135	
	Blue	450 nm	465 nm		20	27	
	Cool White	5400 K	6000 K		160	175	
Color + Neutral White	Red	620 nm	630 nm	A3	85	110	XPLDCL-H0-0000-000SHA3AAAE5
	Green	520 nm	535 nm		120	135	
	Blue	450 nm	465 nm		20	27	
	Neutral White	3700 K	4300 K		160	170	
Color + Warm White	Red	620 nm	630 nm	A2	85	110	XPLDCL-H0-0000-000SHA2AAAE7
	Green	520 nm	535 nm		120	135	
	Blue	450 nm	465 nm		20	27	
	Warm White	2700 K	3300 K		120	165	
Color + PC Amber	Red	620 nm	630 nm	A5	85	110	XPLDPA-H0-0000-000S0A5AAAYS
	Green	520 nm	535 nm		120	135	
	Blue	450 nm	465 nm		20	27	
	PC Amber	YS			100	155	

**Notes:**

- XLamp XP-L Color LED order codes specify only a minimum flux bin and not a maximum. Cree LED may ship reels in flux bins higher than the minimum specified by the order code without advance notice. Shipments will always adhere to the chromaticity or DWL bin restrictions specified by the order code.
- Cree LED maintains a tolerance of ±7% on flux and power measurements, ±0.005 on chromaticity (CCx, CCy) measurements and ±1 nm on dominant wavelength measurements. See the Measurements section (page 18).
- Flux and chromaticity are measured with each LED die connected to independent drive circuits at 700 mA. The flux and chromaticity of each LED die within the XLamp XP-L Color LED package are measured individually.

RELATIVE SPECTRAL POWER DISTRIBUTION ( $I_F = 700 \text{ mA PER LED DIE, } 25 \text{ }^\circ\text{C}$ )

The following graphs represent typical spectral output of the XLamp XP-L Color LED with each LED die on independently.

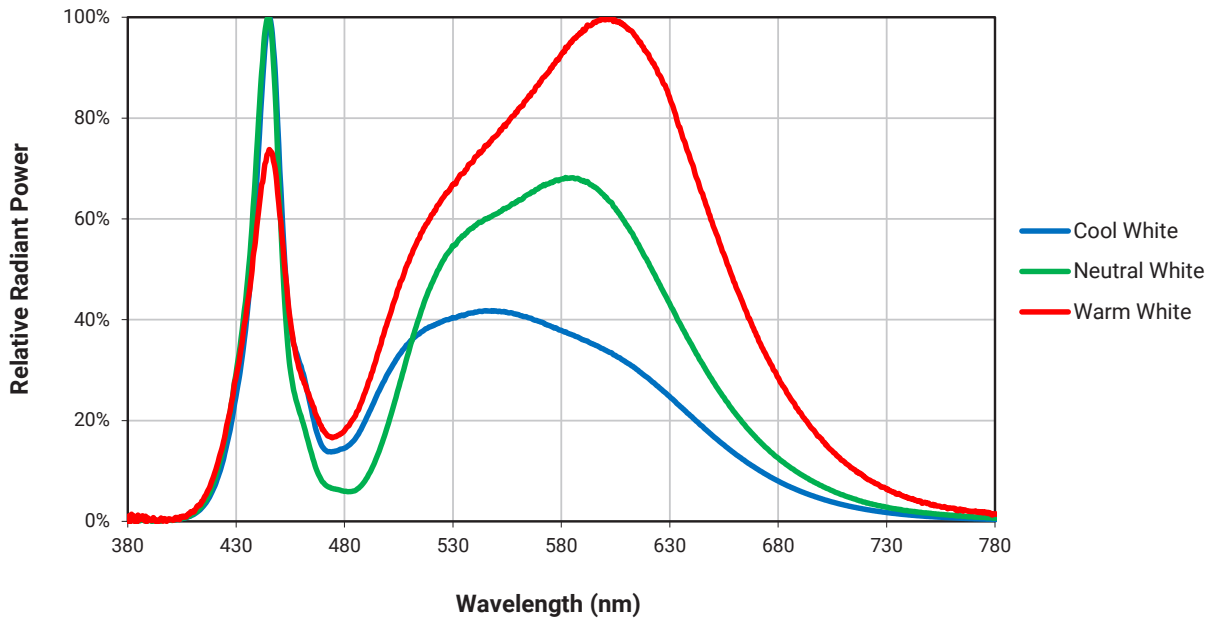
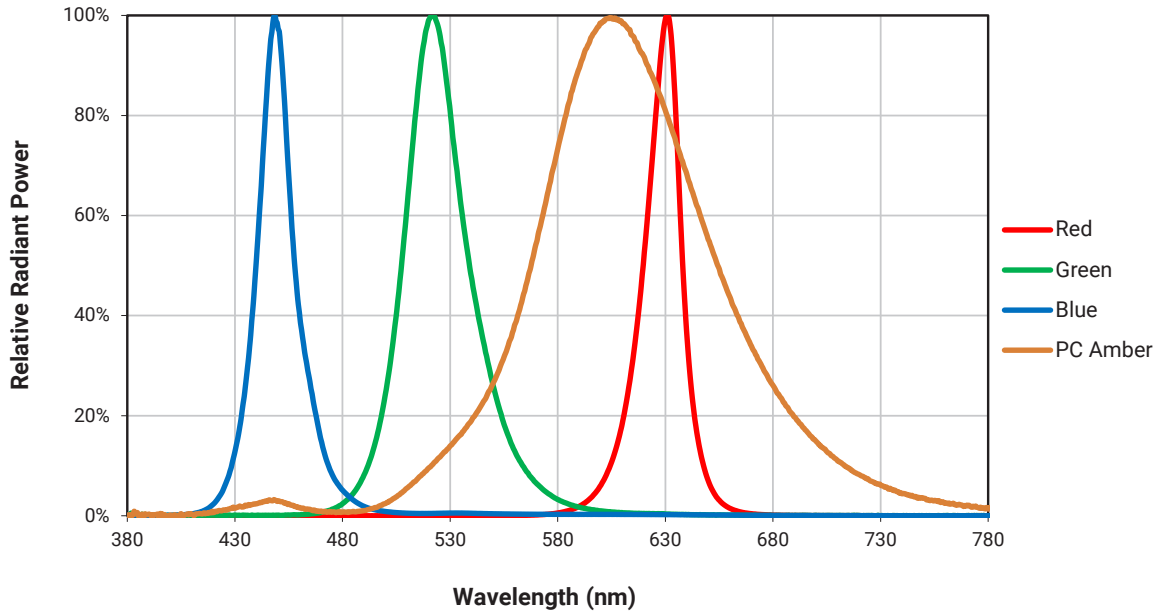

### RELATIVE FLUX VS JUNCTION TEMPERATURE ( $I_F = 700 \text{ mA}$ )

The following graph represents typical performance of each LED die in the XLamp XP-L Color LED.

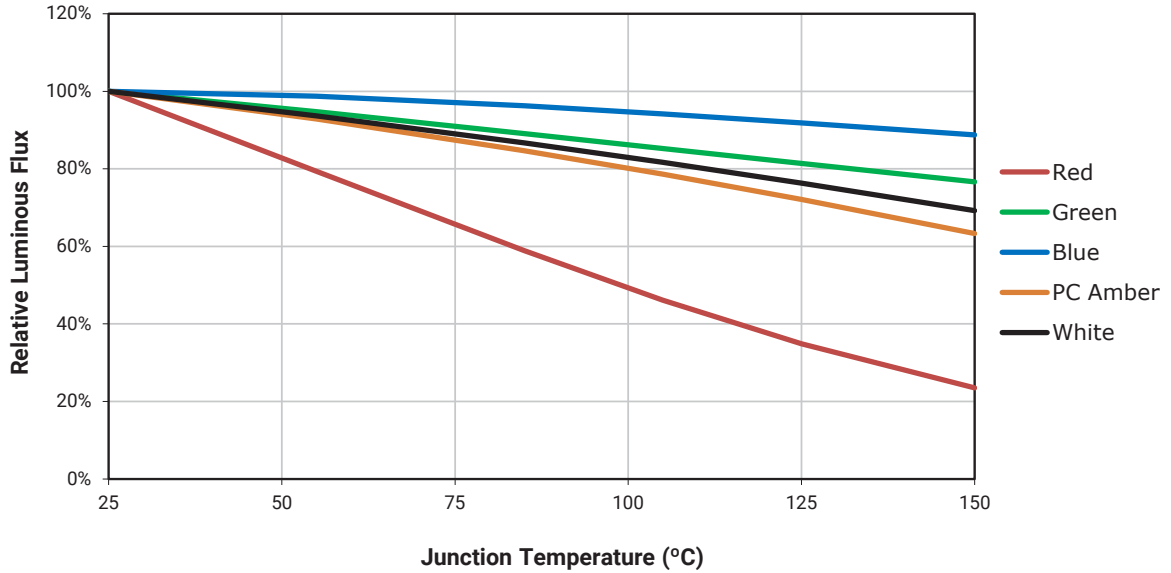

### ELECTRICAL CHARACTERISTICS ( $T_J = 25 \text{ °C}$ )

The following graph represents typical performance of each LED die in the XLamp XP-L Color LED.

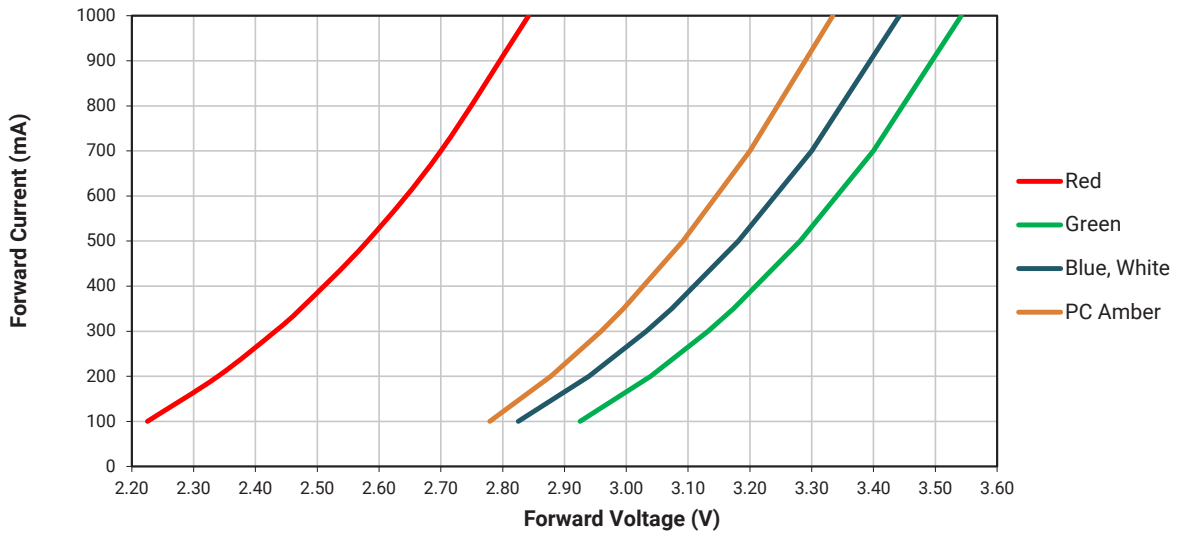

### RELATIVE FLUX VS. CURRENT (T<sub>j</sub> = 25 °C)

The following graph represents typical performance of each LED die in the XLamp XP-L Color LED.

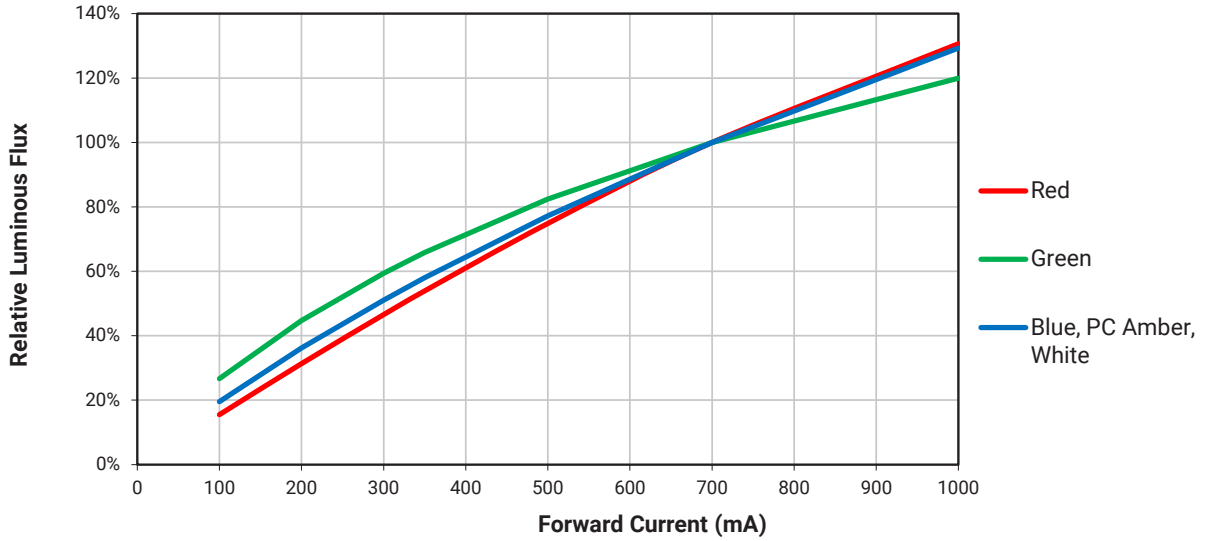

### TYPICAL SPATIAL DISTRIBUTION

The following graphs represent typical output of the XLamp XP-L Color LED with all four LEDs on simultaneously.

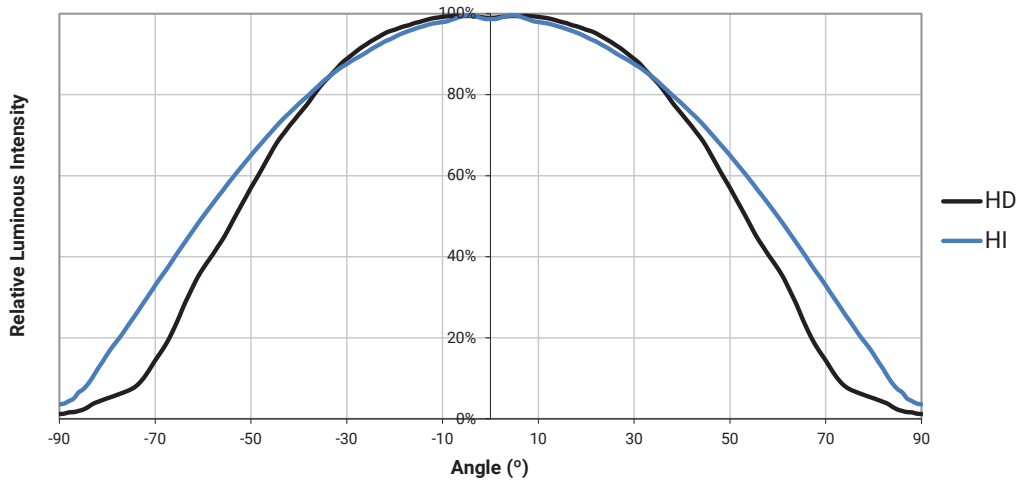

## BIN AND ORDER CODE FORMATS

Bin codes and order codes are configured in the following manner:

### Order Code

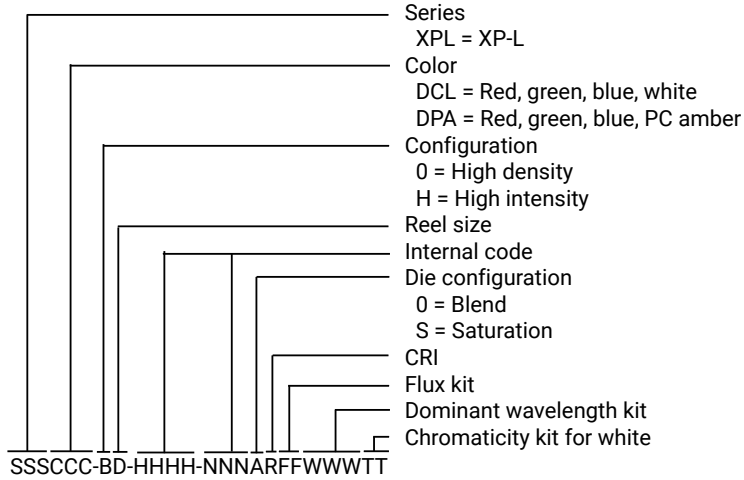

### Bin Code

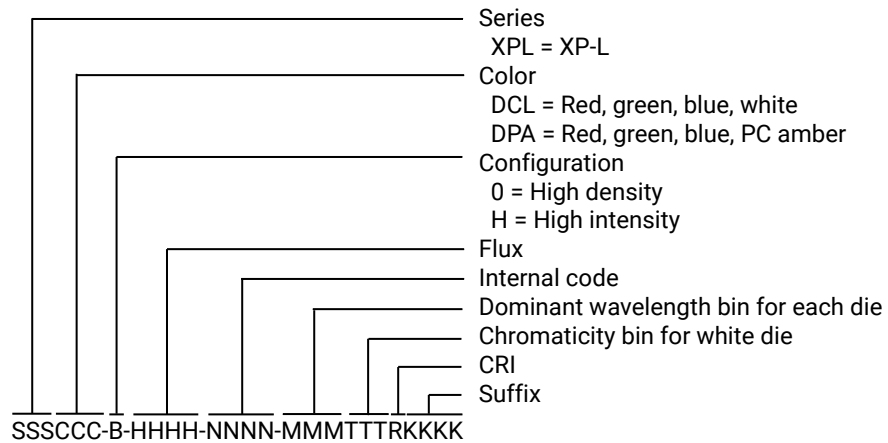

## PERFORMANCE GROUPS – LUMINOUS FLUX

Each LED die in the XLamp XP-L Color LED is tested individually for luminous flux and placed into one of the following luminous-flux groups.

### High Density

Color	Group Code	Mean Luminous Flux (lm) @ 700 mA	Maximum Luminous Flux (lm) @ 700 mA
Red	G	95	135
	H	135	175
Green	N	145	205
	P	205	265
Blue	B	20	50
	C	50	80
White	6	140	180
	7	180	220
	8	220	260

### High Intensity

Color	Group Code	Mean Luminous Flux (lm) @ 700 mA	Maximum Luminous Flux (lm) @ 700 mA
Red	E	85	125
	F	125	165
Green	K	120	180
	L	180	240
Blue	B	20	50
	C	50	80
White	2	120	160
	3	160	200
	4	200	240
PC Amber	5	100	140
	6	140	180

- Flux and chromaticity are measured with each LED die connected to independent drive circuits at 700 mA.

### PERFORMANCE GROUPS – DOMINANT WAVELENGTH

The red, green and blue LED dies in the XLamp XP-L Color LED are tested individually for dominant wavelength (DWL) and sorted into one of the DWL bins defined below.

Color	DWL Group	Minimum DWL @ 700 mA	Maximum DWL @ 700 mA
Red	A	620	630
	2	520	525
Green	3	525	530
	4	530	535
	K	450	455
Blue	L	455	460
	M	460	465

### PERFORMANCE GROUPS – CHROMATICITY (I<sub>F</sub> = 700 mA PER LED DIE)

The white LED die in the XLamp XP-L Color LED is individually tested for chromaticity at 700 mA and placed into one of the regions defined by the bounding coordinates shown below.

Region	x	y	Region	x	y	Region	x	y	Region	x	y
2A	0.3215	0.3350	2B	0.3207	0.3462	2C	0.3290	0.3538	2D	0.3290	0.3417
	0.3290	0.3417		0.3290	0.3538		0.3376	0.3616		0.3371	0.3490
	0.3290	0.3300		0.3290	0.3417		0.3371	0.3490		0.3366	0.3369
	0.3222	0.3243		0.3215	0.3350		0.3290	0.3417		0.3290	0.3300
5A	.3670	.3578	5B	.3702	.3722	5C	.3825	.3798	5D	.3783	.3646
	.3702	.3722		.3736	.3874		.3869	.3958		.3825	.3798
	.3825	.3798		.3869	.3958		.4006	.4044		.3950	.3875
	.3783	.3646		.3825	.3798		.3950	.3875		.3898	.3716
7A	.4147	.3814	7B	.4221	.3984	7C	.4342	.4028	7D	.4259	.3853
	.4221	.3984		.4299	.4165		.4430	.4212		.4342	.4028
	.4342	.4028		.4430	.4212		.4562	.4260		.4465	.4071
	.4259	.3853		.4342	.4028		.4465	.4071		.4373	.3893

Color Temperatures – 3-Step Ellipse						
Bin Code	CCT	Center Point		Major Axis	Minor Axis	Rotation Angle (°)
		x	y	a	b	
40G	4000 K	0.3818	0.3797	0.00939	0.00402	53.7
30G	3000 K	0.4338	0.4030	0.00834	0.00408	53.2

PERFORMANCE GROUPS – CHROMATICITY ( $T_j = 85\text{ }^\circ\text{C}$ ) - CONTINUED

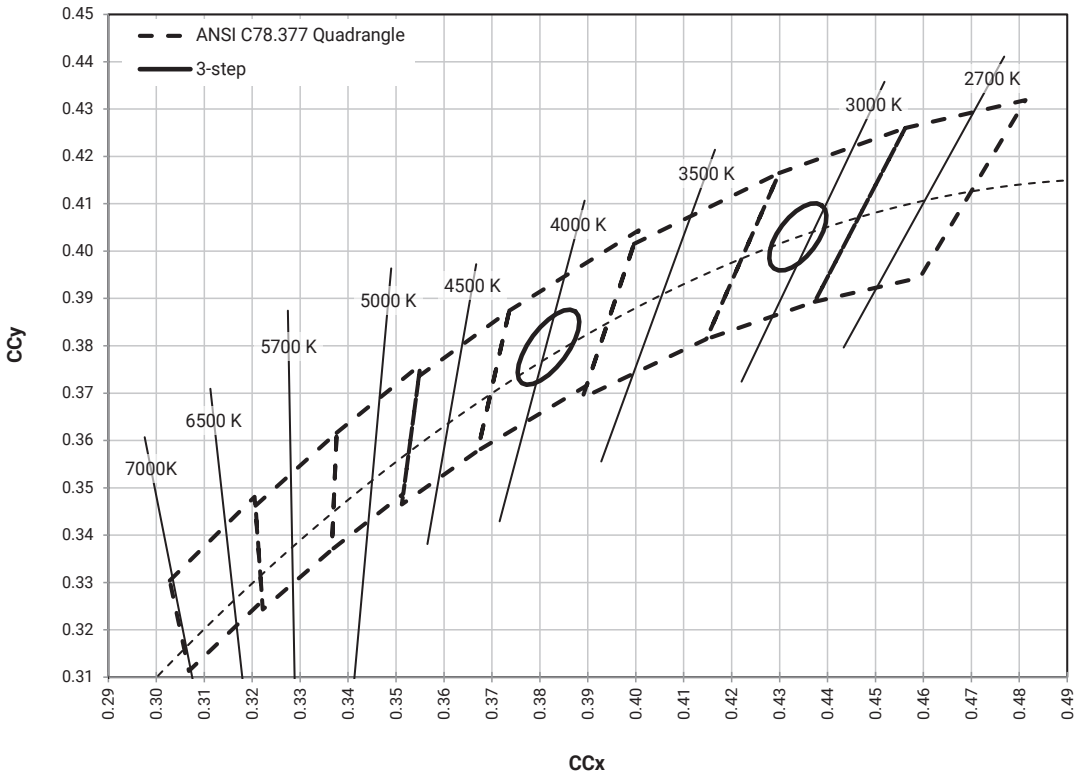

PERFORMANCE GROUPS - CHROMATICITY ( $T_j = 85^\circ\text{C}$ ) - CONTINUED

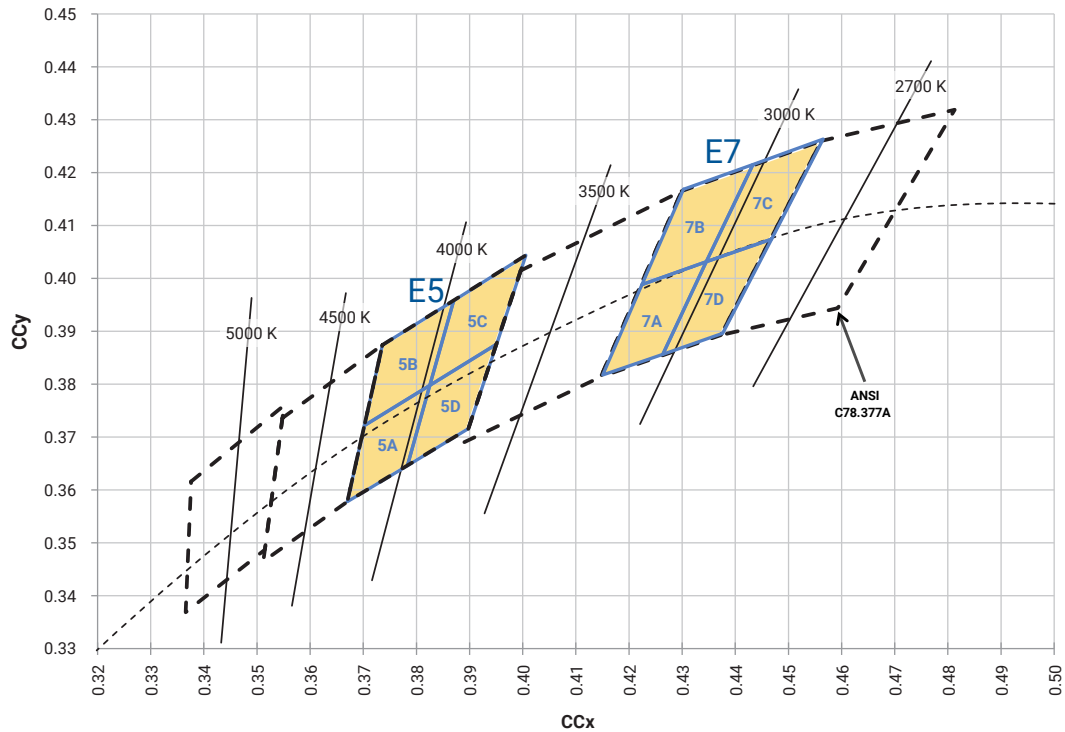
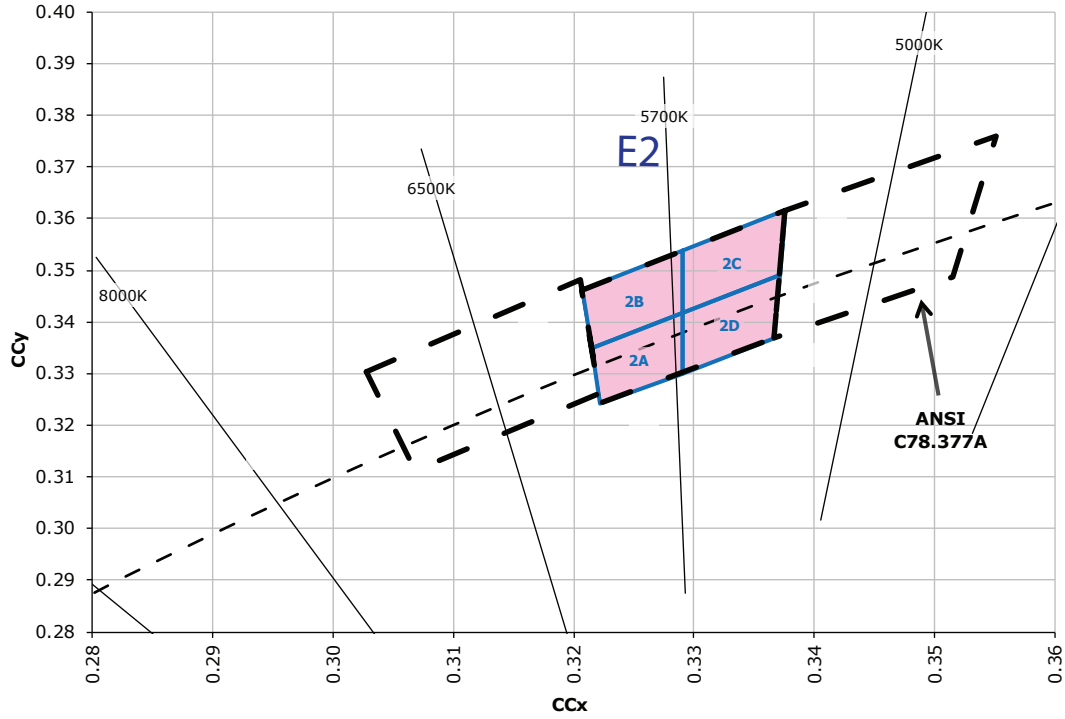

**PERFORMANCE GROUPS – CHROMATICITY ( $T_j = 85\text{ }^\circ\text{C}$ ) - CONTINUED**

XLamp XP-L PC amber LEDs are tested for chromaticity and placed into one of the regions defined by the following bounding coordinates.

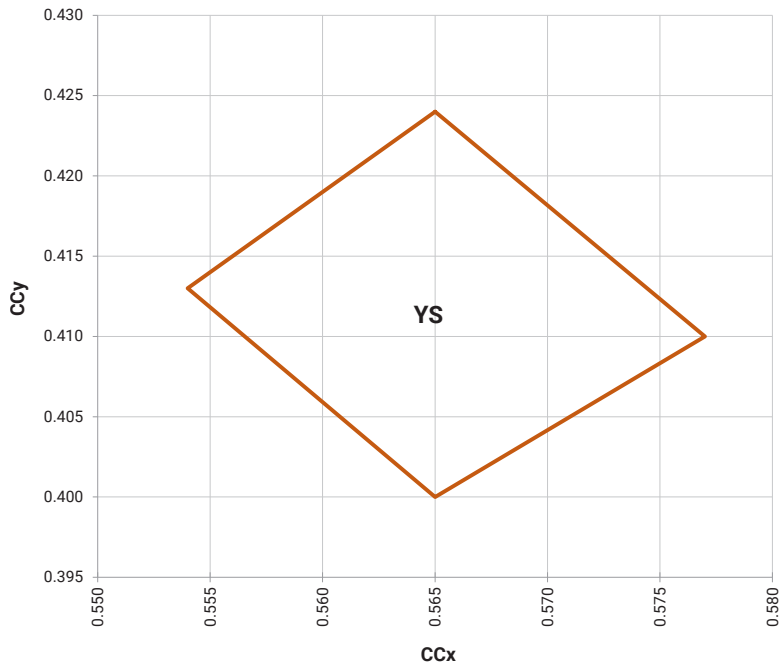

Chromaticity Bin	CCx	CCy
YS	0.5650	0.4240
	0.5770	0.4100
	0.5650	0.4000
	0.5540	0.4130

## PERFORMANCE GROUPS - CHROMATICITY BINS

The following table lists standard kit numbers and chromaticity bins. Kit numbers completely describe an order code's color or chromaticity bins and luminous flux range. For other flux and chromaticity combinations, contact Cree LED or an authorized distributor,

Color	CCT	Kit Number	Chromaticity Bins
Cool White	5700 K	AAAE2	2A, 2B, 2C, 2D
Neutral White	4000 K	AAAE5	5A, 5B, 5C, 5D, 40G
		AAA5G	40G
Warm White	3000 K	AAAE7	7A, 7B, 7C, 7D, 30G
		AAA7G	30G

For other flux and chromaticity combinations, contact Cree LED or an authorized distributor.

## REFLOW SOLDERING CHARACTERISTICS

In testing, Cree LED has found XLamp XP-L Color LEDs to be compatible with JEDEC J-STD-020C, using the parameters listed below. As a general guideline, Cree LED recommends that users follow the recommended soldering profile provided by the manufacturer of the solder paste used, and therefore it is the lamp or luminaire manufacturer’s responsibility to determine applicable soldering requirements.

Note that this general guideline may not apply to all PCB designs and configurations of reflow soldering equipment.

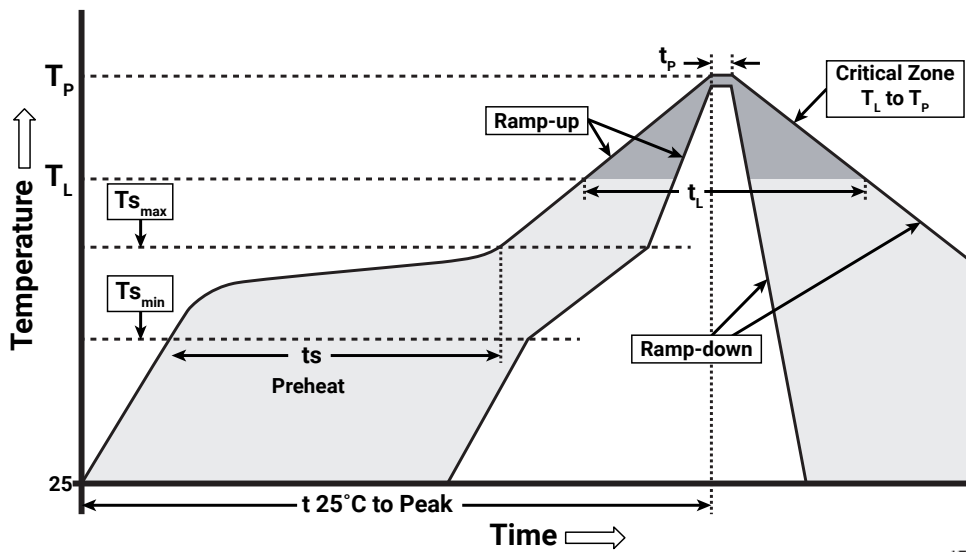

IPC/JEDEC J-STD-020C

Profile Feature	Lead-Free Solder
Average Ramp-Up Rate ( $T_{s_{max}}$ to $T_p$ )	1.2 °C/second
Preheat: Temperature Min ( $T_{s_{min}}$ )	120 °C
Preheat: Temperature Max ( $T_{s_{max}}$ )	170 °C
Preheat: Time ( $t_{s_{min}}$ to $t_{s_{max}}$ )	65-150 seconds
Time Maintained Above: Temperature ( $T_L$ )	217 °C
Time Maintained Above: Time ( $t_L$ )	45-90 seconds
Peak/Classification Temperature ( $T_p$ )	235 - 245 °C
Time Within 5 °C of Actual Peak Temperature ( $t_p$ )	20-40 seconds
Ramp-Down Rate	1 - 6 °C/second
Time 25 °C to Peak Temperature	4 minutes max.

Note: All temperatures refer to the topside of the package, measured on the package body surface.

## NOTES

---

### Measurements

The luminous flux, radiant power, chromaticity, forward voltage and CRI measurements in this document are binning specifications only and solely represent product measurements as of the date of shipment. These measurements will change over time based on a number of factors that are not within Cree LED's control and are not intended or provided as operational specifications for the products. Calculated values are provided for informational purposes only and are not intended or provided as specifications.

### Pre-Release Qualification Testing

Please read the [LED Reliability Overview](#) for details of the qualification process Cree LED applies to ensure long-term reliability for XLamp LEDs and details of Cree LED's pre-release qualification testing for XLamp LEDs.

### RoHS Compliance

The levels of RoHS restricted materials in this product are below the maximum concentration values (also referred to as the threshold limits) permitted for such substances, or are used in an exempted application, in accordance with EU Directive 2011/65/EC (RoHS2), as implemented January 2, 2013. RoHS Declarations for this product can be obtained from your Cree LED representative or from the [Product Ecology](#) section of the Cree LED website.

### REACH Compliance

REACH substances of very high concern (SVHCs) information is available for this product. Since the European Chemical Agency (ECHA) has published notice of their intent to frequently revise the SVHC listing for the foreseeable future, please contact a Cree LED representative to insure you get the most up-to-date REACH SVHC Declaration. REACH banned substance information (REACH Article 67) is also available upon request.

### UL® Recognized Component

This product meets the requirements to be considered a UL Recognized Component with Level 4 enclosure consideration. The LED package or a portion thereof has been investigated as a fire and electrical enclosure per ANSI/UL 8750.

## MECHANICAL DIMENSIONS

Thermal vias, if present, are not shown on these drawings.

All measurements are  $\pm 0.13$  mm unless otherwise indicated.

### High Density

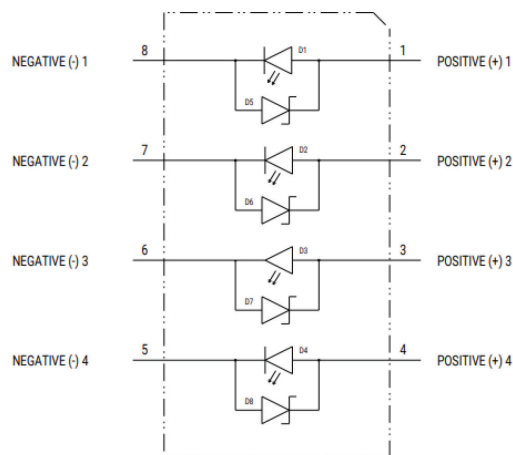
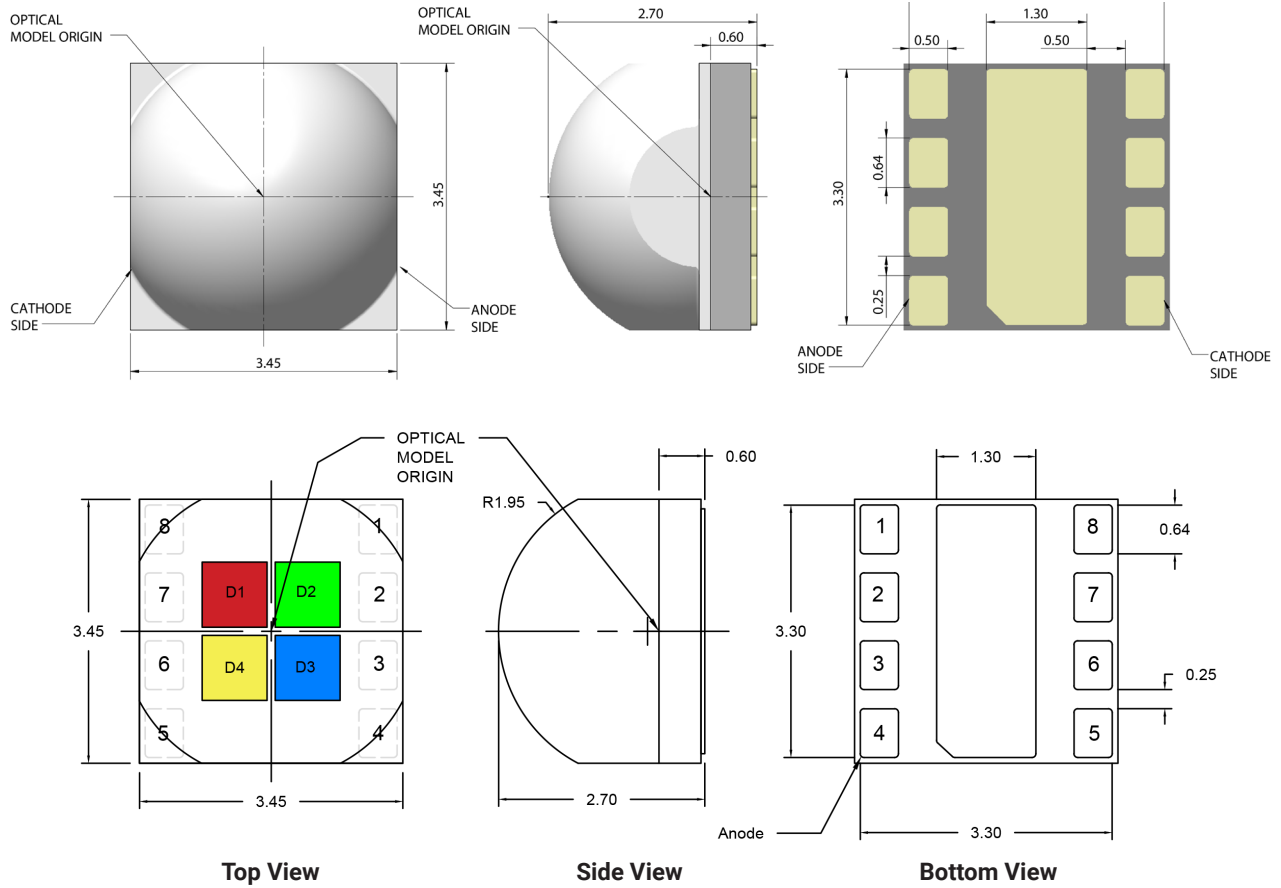

**Color**  
 D1: Red  
 D2: Green  
 D3: Blue  
 D4: White

MECHANICAL DIMENSIONS - CONTINUED

High Intensity - Blend

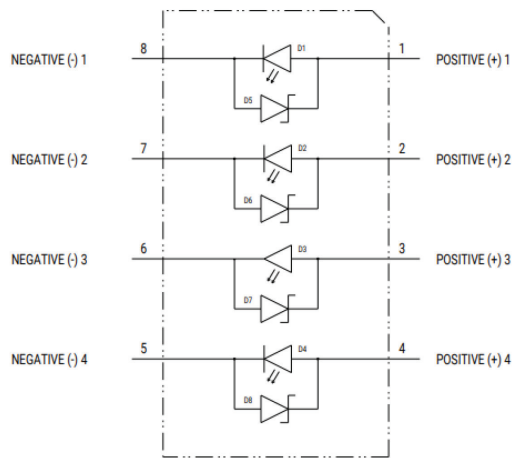
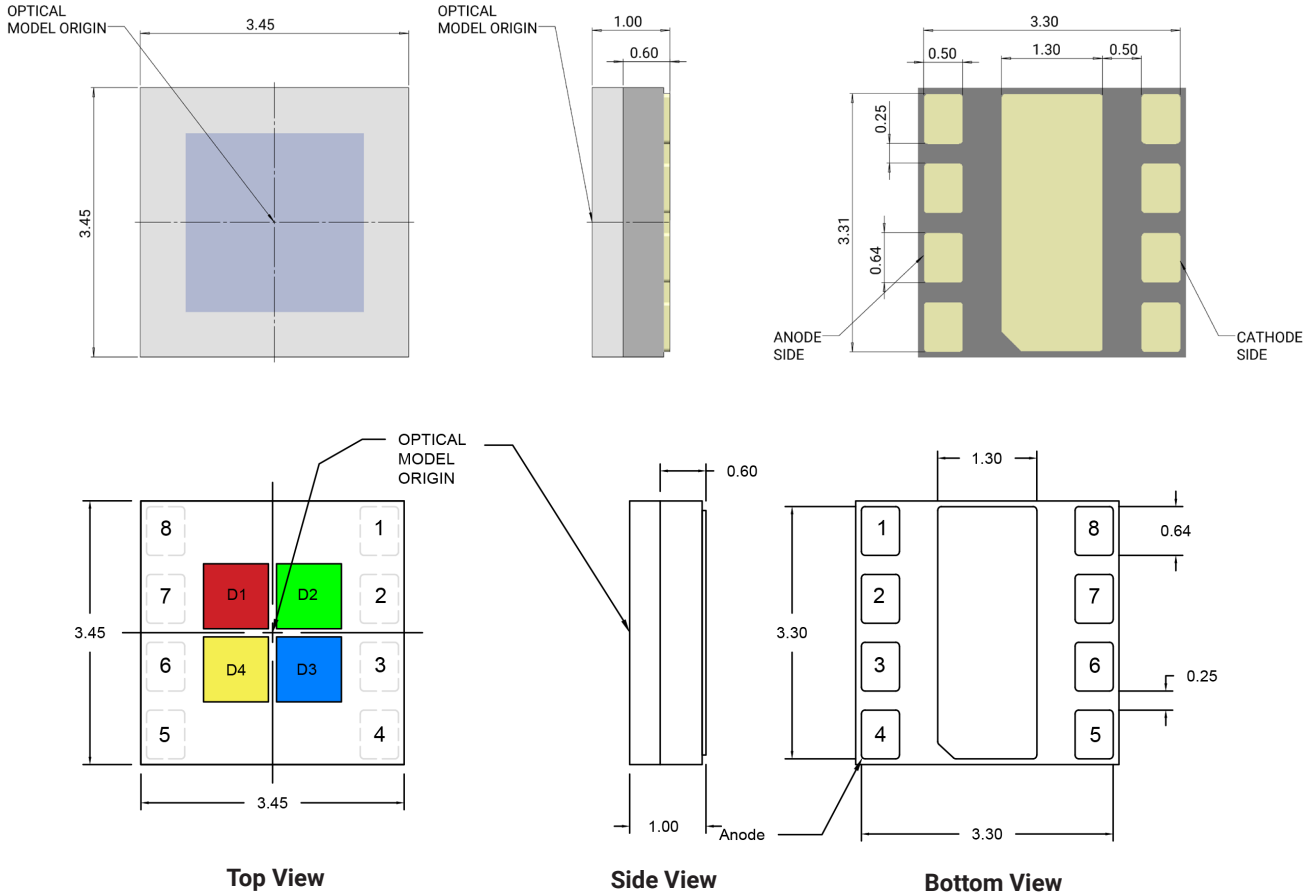

- Color**
- D1: Red
  - D2: Green
  - D3: Blue
  - D4: White

MECHANICAL DIMENSIONS - CONTINUED

High Intensity - Saturation

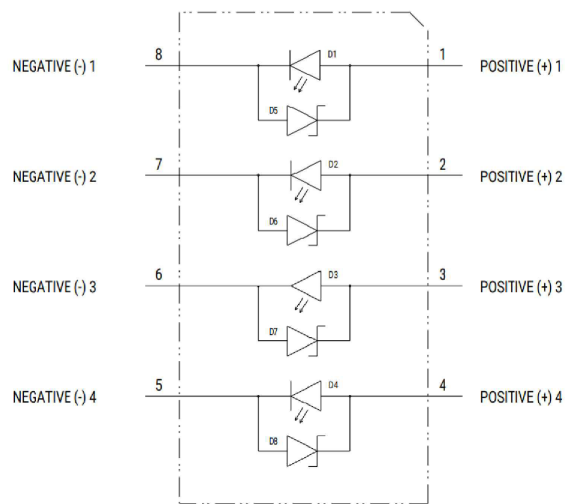
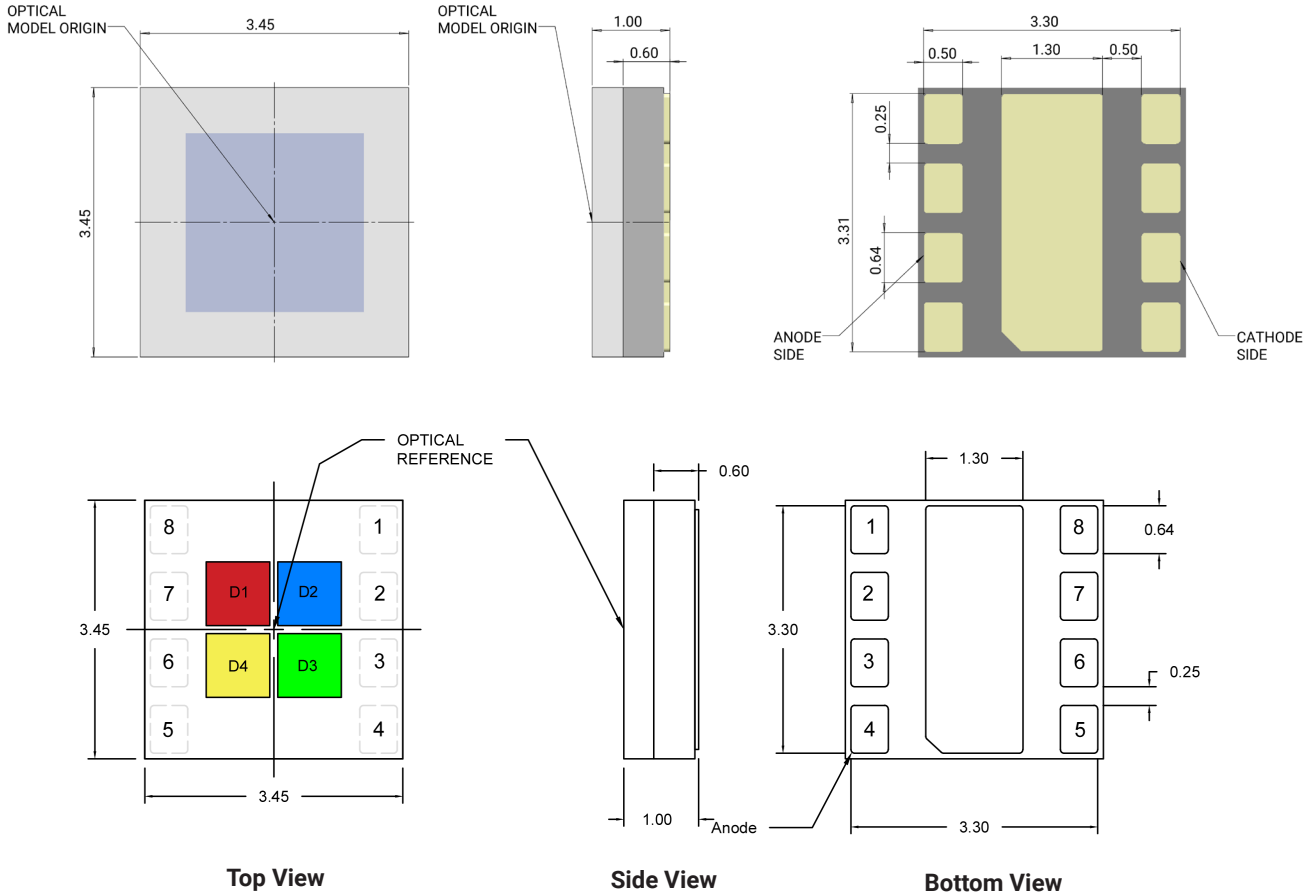

- Color**
- D1: Red
  - D2: Blue
  - D3: Green
  - D4: White

MECHANICAL DIMENSIONS - CONTINUED

High Intensity - Saturation (PC Amber)

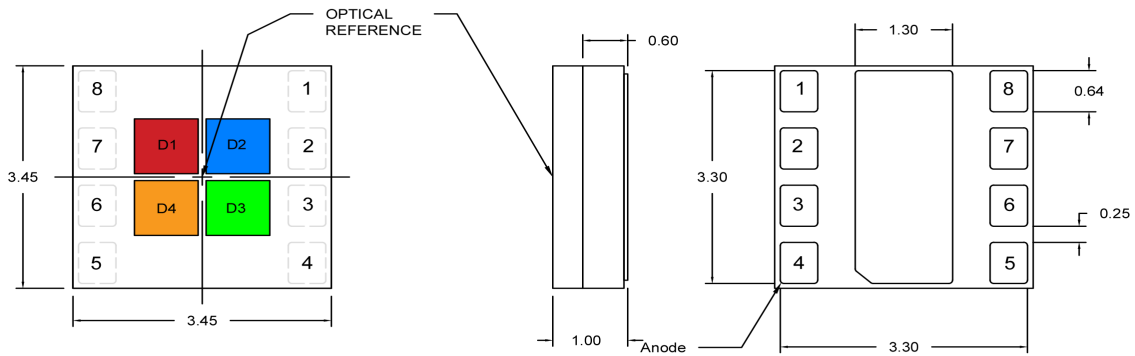
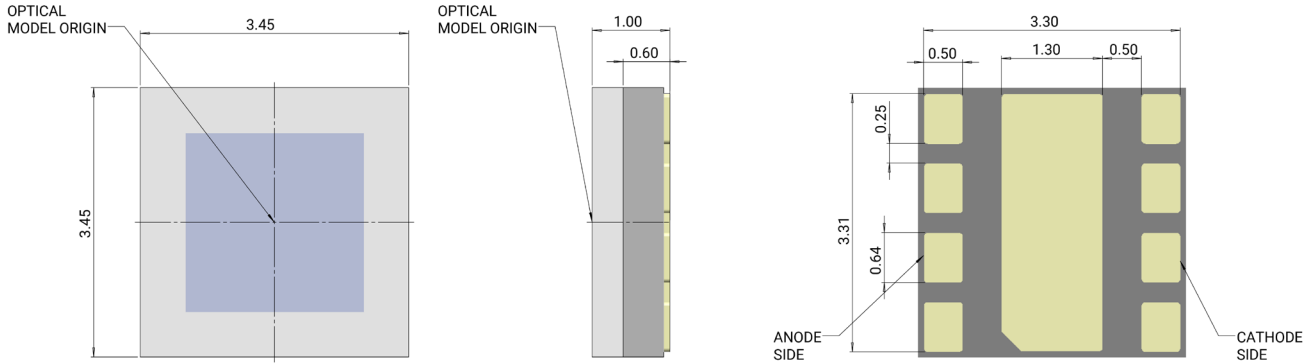

Top View

Side View

Bottom View

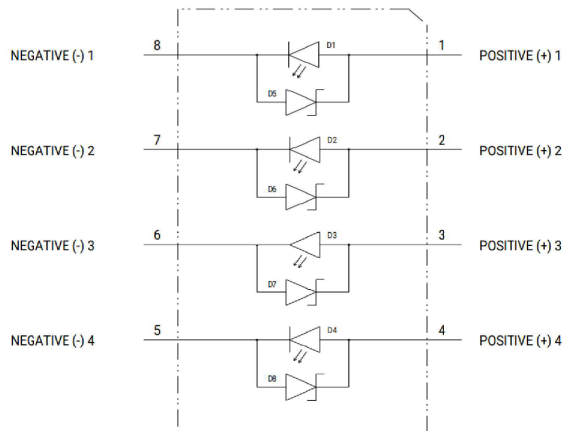

- Color**  
 D1: Red  
 D2: Blue  
 D3: Green  
 D4: PC Amber

MECHANICAL DIMENSIONS - CONTINUED

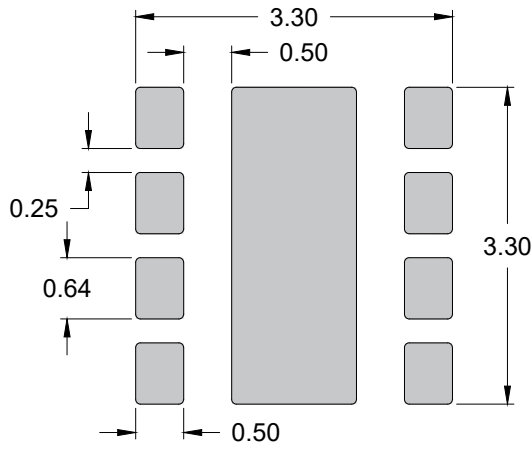

Recommended PCB Solder Pad

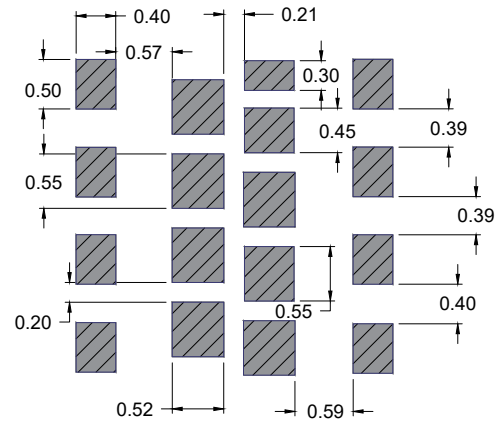

Recommended Stencil Pattern

**TAPE AND REEL**

All Cree LED carrier tapes conform to EIA-481D, Automated Component Handling Systems Standard.

Except as noted, all dimensions in mm.

All measurements are ±0.10 mm unless otherwise indicated.

**High Density**

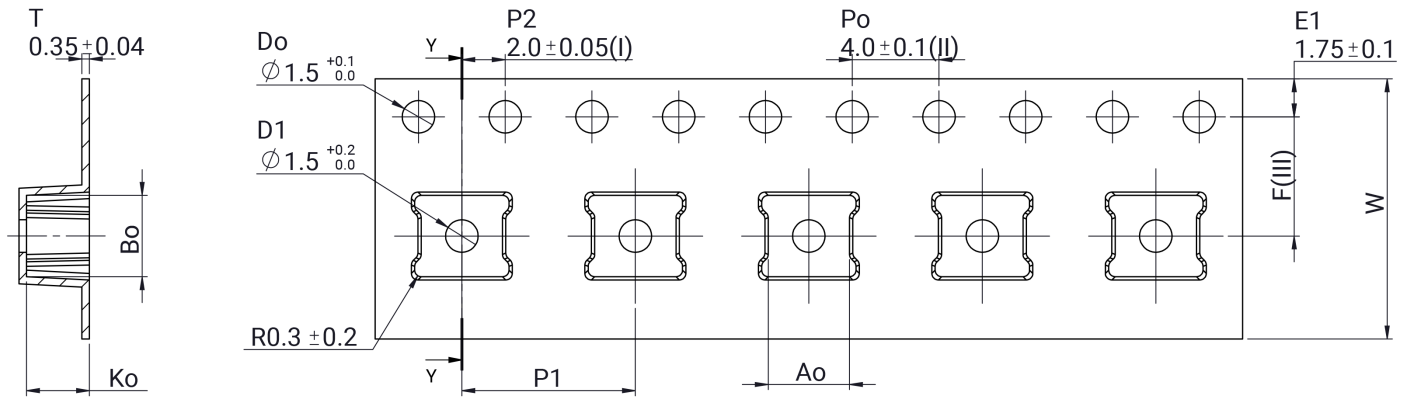

SECTION Y-Y

Item	Ao	Bo	Ko	P1	F	W
Dimension	3.75	3.75	2.90	8.00	5.50±0.05	12.00+0.3/-0.1

**TAPE AND REEL - CONTINUED**

All Cree LED carrier tapes conform to EIA-481D, Automated Component Handling Systems Standard.

Except as noted, all dimensions in mm.

All measurements are ±0.10 mm unless otherwise indicated.

**High Intensity**

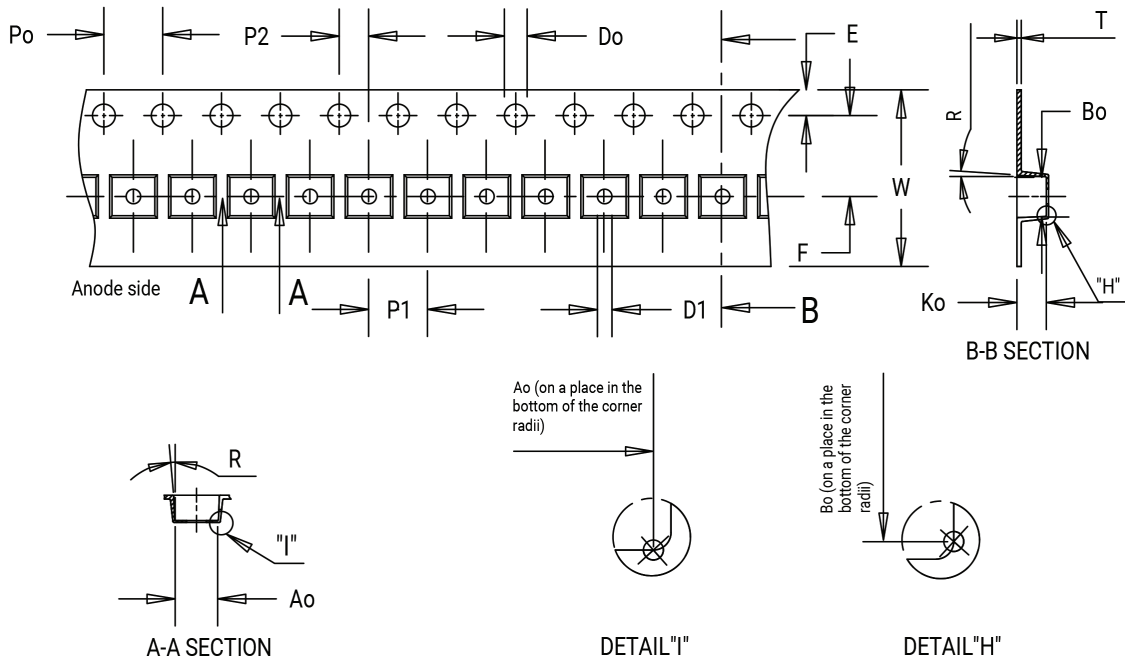

Item	Ao	Bo	Ko	P0	P1	P2	T	E	F	Do	D1	W
Dimension	3.70	3.70	1.20	4.00	8.00	2.00	0.30±0.05	1.75	5.50	1.50+0.10/-0	1.50 min.	12.00+0.2/-0.1

TAPE AND REEL - CONTINUED

High Density

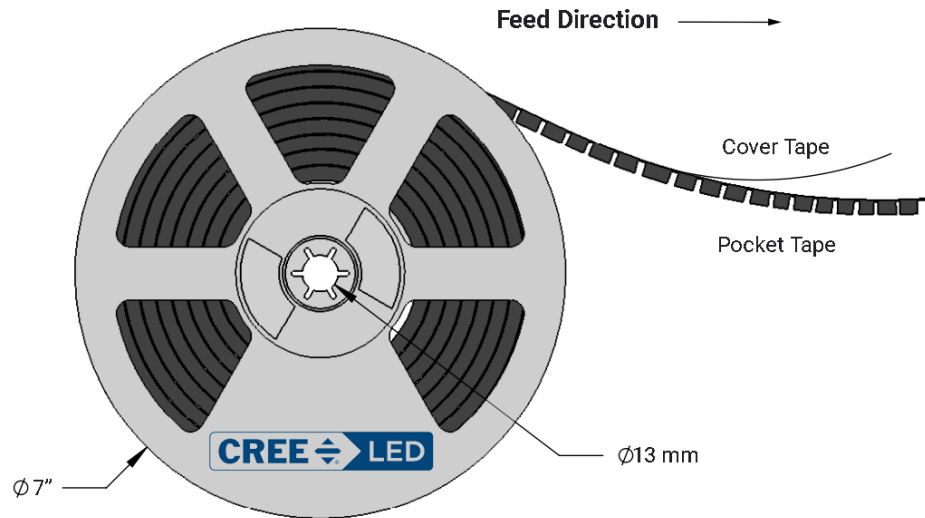
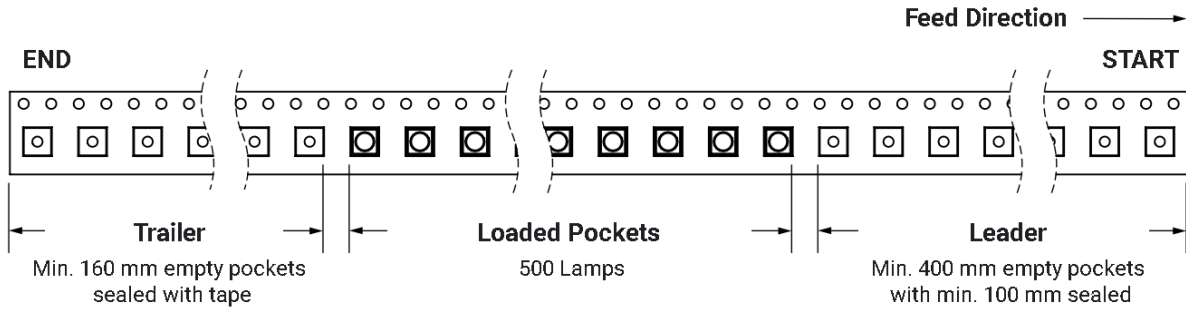

TAPE AND REEL - CONTINUED

High Intensity

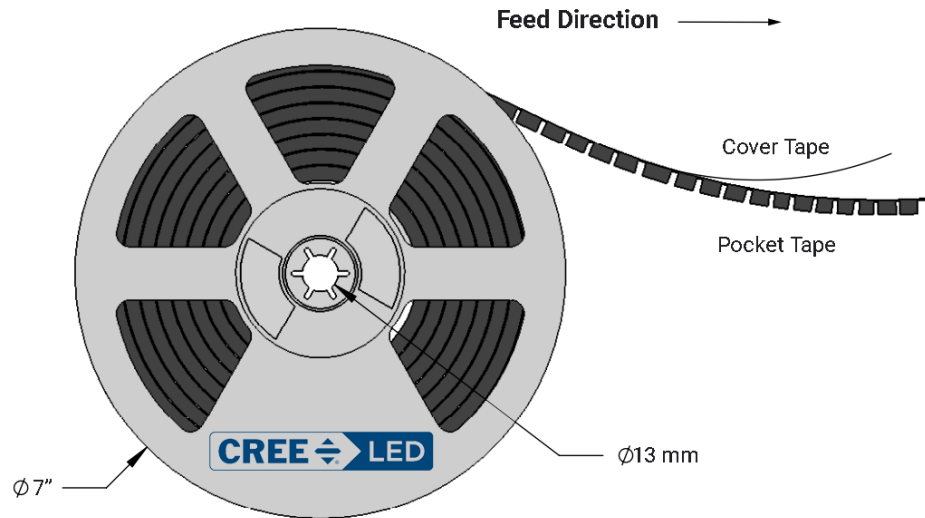
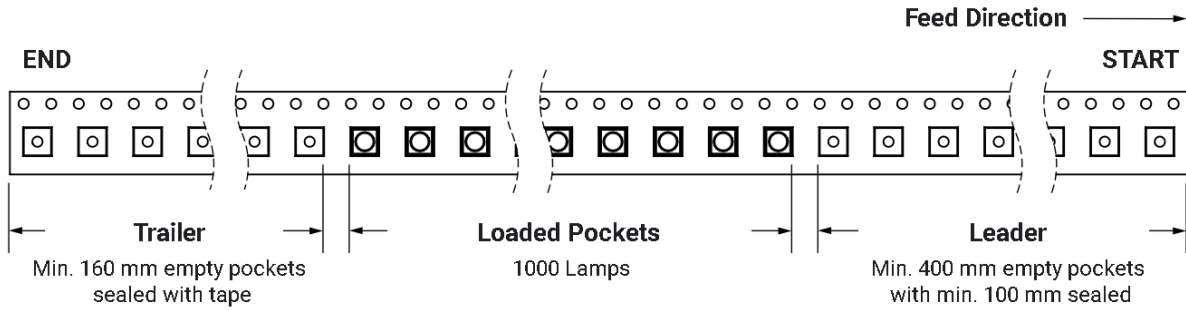

PACKAGING

Unpackaged Reel

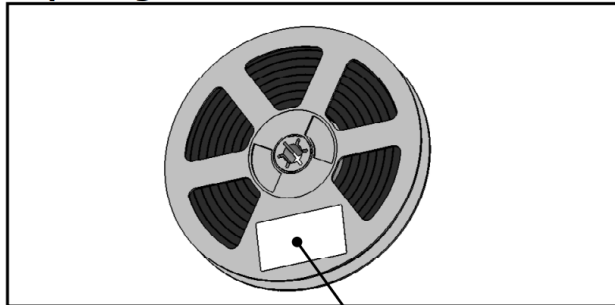

Label with Cree LED Bin Code, Quantity, Reel ID

Packaged Reel

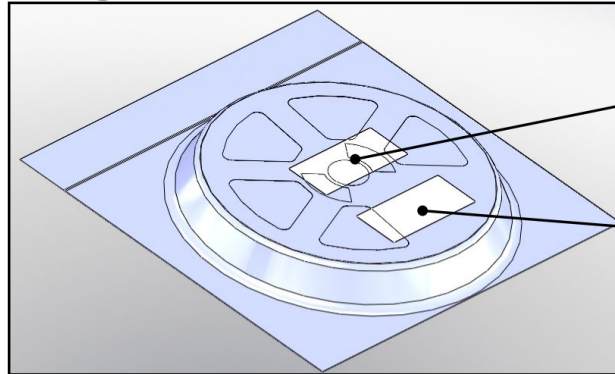

Label with Cree LED Order Code, Quantity, Reel ID, PO#

Label with Cree LED Bin Code, Quantity, Reel ID

Boxed Reel

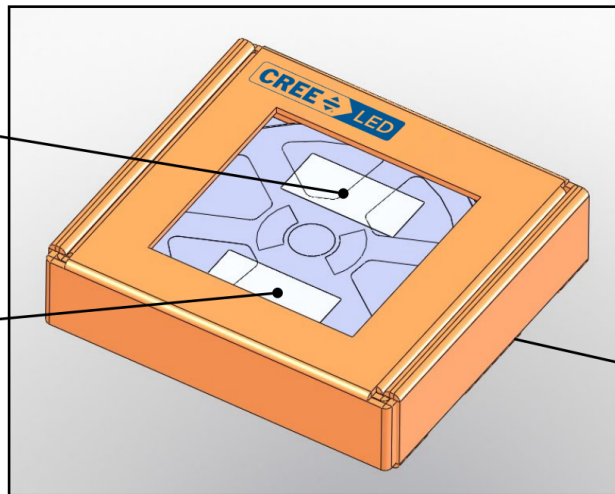

Label with Cree LED Order Code, Quantity, Reel ID, PO#

Label with Cree LED Bin Code, Quantity, Reel ID

Patent Label (on bottom of box)