

- Ultra compact DIP package
13.2 x 9.1 x 10.2 mm
- I/O-isolation 1'600 VDC
- Fully regulated outputs
- Operating temperature range
-40°C to +70°C without derating
- Short circuit protection
- Remote On/Off
- Designed to meet IEC/EN/UL 62368-1
(not certified)
- 3-year product warranty

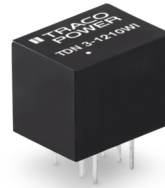

The TDN 3WI Series comprises 3 Watt fully regulated, high performance DC/DC converters. They come in a compact cubical package of only 1.23 cm³. Full load operation is reliable up to 70°C environment temperature. With 1'600 VDC I/O-isolation voltage, external On/Off, and short current protection they cover a wide range of application when space is limited. The input of the converters is designed for a wide voltage range (4:1) and minimum load is not required.

The functional I/O-isolation system is designed to meet IEC/EN/UL 62368-1 (not certified) with a test voltage (60 s) of 1'600 VDC.

Models						
Order Code	Input Voltage Range	Output 1		Output 2		Efficiency typ.
		Vnom	I _{max}	Vnom	I _{max}	
TDN 3-1210WI	4.5 - 18 VDC (12 VDC nom.)	3.3 VDC	700 mA			76 %
TDN 3-1211WI		5 VDC	600 mA			80 %
TDN 3-1219WI		9 VDC	333 mA			81 %
TDN 3-1212WI		12 VDC	250 mA			83 %
TDN 3-1213WI		15 VDC	200 mA			84 %
TDN 3-1215WI		24 VDC	125 mA			82 %
TDN 3-1221WI		+5 VDC	300 mA	-5 VDC	300 mA	80 %
TDN 3-1222WI		+12 VDC	125 mA	-12 VDC	125 mA	82 %
TDN 3-1223WI		+15 VDC	100 mA	-15 VDC	100 mA	82 %
TDN 3-2410WI	9 - 36 VDC (24 VDC nom.)	3.3 VDC	700 mA			77 %
TDN 3-2411WI		5 VDC	600 mA			80 %
TDN 3-2419WI		9 VDC	333 mA			81 %
TDN 3-2412WI		12 VDC	250 mA			83 %
TDN 3-2413WI		15 VDC	200 mA			83 %
TDN 3-2415WI		24 VDC	125 mA			82 %
TDN 3-2421WI		+5 VDC	300 mA	-5 VDC	300 mA	80 %
TDN 3-2422WI		+12 VDC	125 mA	-12 VDC	125 mA	82 %
TDN 3-2423WI		+15 VDC	100 mA	-15 VDC	100 mA	82 %
TDN 3-4810WI	18 - 75 VDC (48 VDC nom.)	3.3 VDC	700 mA			77 %
TDN 3-4811WI		5 VDC	600 mA			80 %
TDN 3-4819WI		9 VDC	333 mA			81 %
TDN 3-4812WI		12 VDC	250 mA			83 %
TDN 3-4813WI		15 VDC	200 mA			83 %
TDN 3-4815WI		24 VDC	125 mA			82 %
TDN 3-4821WI		+5 VDC	300 mA	-5 VDC	300 mA	80 %
TDN 3-4822WI		+12 VDC	125 mA	-12 VDC	125 mA	82 %
TDN 3-4823WI		+15 VDC	100 mA	-15 VDC	100 mA	82 %

Input Specifications

Input Current	- At no load	12 Vin models: 40 mA typ. 24 Vin models: 24 mA typ. 48 Vin models: 13 mA typ.
Surge Voltage		12 Vin models: 25 VDC max. (1 s max.) 24 Vin models: 50 VDC max. (1 s max.) 48 Vin models: 100 VDC max. (1 s max.)
Reflected Ripple Current		20 mAp-p typ.
Recommended Input Fuse		12 Vin models: 1'600 mA (slow blow) 24 Vin models: 800 mA (slow blow) 48 Vin models: 500 mA (slow blow) (The need of an external fuse has to be assessed in the final application.)
Input Filter		Internal Capacitor

Output Specifications

Voltage Set Accuracy		±1% max.
Regulation	- Input Variation (Vmin - Vmax) - Load Variation (0 - 100%) - Cross Regulation (25% / 100% asym. load)	single output models: 0.2% max. dual output models: 0.2% max. single output models: 1% max. dual output models: 1% max. (Output 1) 1% max. (Output 2) dual output models: 5% max.
Ripple and Noise	- 20 MHz Bandwidth	50 mVp-p typ.
Capacitive Load	- single output - dual output	3.3 Vout models: 4'700 µF max. 5 Vout models: 2'530 µF max. 9 Vout models: 1'470 µF max. 12 Vout models: 1'220 µF max. 15 Vout models: 1'000 µF max. 24 Vout models: 470 µF max. 5 / -5 Vout models: 1'470 / 1'470 µF max. 12 / -12 Vout models: 680 / 680 µF max. 15 / -15 Vout models: 470 / 470 µF max.
Minimum Load		Not required
Temperature Coefficient		±0.02 %/K max.
Start-up Time		10 ms typ. / 20 ms max.
Short Circuit Protection		Continuous, Automatic recovery
Transient Response	- Response Time	500 µs typ. (25% Load Step)

Safety Specifications

Standards	- IT / Multimedia Equipment	Designed for IEC/EN/UL 62368-1 (not certified)
Over Voltage Category		Not mains connected

EMC Specifications

EMI (Emissions)	- Conducted Emissions	EN 55032 class A (with external filter)
	- Radiated Emissions	EN 55032 class B (with external filter)
		EN 55032 class A (with external filter)
		EN 55032 class B (with external filter)
		External filter proposal: www.tracopower.com/tdn3wi-emc-filter

All specifications valid at nominal voltage, resistive full load and +25°C after warm-up time, unless otherwise stated.

EMS (Immunity)	- Electrostatic Discharge	Air: EN 61000-4-2, ±8 kV, perf. criteria A
	- RF Electromagnetic Field	Contact: EN 61000-4-2, ±6 kV, perf. criteria A
	- EFT (Burst) / Surge	EN 61000-4-3, 10 V/m, perf. criteria A
		EN 61000-4-4, ±2 kV, perf. criteria A
		EN 61000-4-5, ±1 kV, perf. criteria A
	- Conducted RF Disturbances	Ext. input component: KY 220 µF, 100 V
	- PF Magnetic Field	EN 61000-4-6, 10 Vrms, perf. criteria A
		Continuous: EN 61000-4-8, 100 A/m, perf. criteria A
		1 s: EN 61000-4-8, 1000 A/m, perf. criteria A

General Specifications

Relative Humidity		95% max. (non condensing)
Temperature Ranges	- Operating Temperature	-40°C to +70°C (without derating)
	- Case Temperature	+105°C max.
	- Storage Temperature	-55°C to +125°C
Power Derating	- High Temperature	2.86 %/K above 70°C
		See application note: www.tracopower.com/tdn3wi-cc
Cooling System		Natural convection (20 LFM)
Remote Control	- Current Controlled Remote (passive = on)	On: open circuit
		Off: 2 to 4 mA current (no internal resistor)
		Refers to 'Remote' and '-Vin' Pin
	- Off Idle Input Current	External circuit proposal: www.tracopower.com/info/current-remote.pdf
		2.5 mA max.
Regulator Topology		RCC Converter
Switching Frequency		100 kHz min. (PFM)
Insulation System		Functional Insulation
Isolation Test Voltage	- Input to Output, 60 s	1'600 VDC
Isolation Resistance	- Input to Output, 500 VDC	1'000 MΩ min.
Isolation Capacitance	- Input to Output, 100 kHz, 1 V	50 pF max.
Reliability	- Calculated MTBF	5'630'000 h (MIL-HDBK-217F, ground benign)
Washing Process		According to Cleaning Guideline
		www.tracopower.com/info/cleaning.pdf
Environment	- Vibration	MIL-STD-810F
	- Thermal Shock	MIL-STD-810F
Housing Material		Non-conductive Plastic (UL 94 V-0 rated)
Base Material		Non-conductive Plastic (UL 94 V-0 rated)
Potting Material		Silicone (UL 94 V-0 rated)
Pin Material		Copper
Pin Foundation Plating		Nickel (2 - 3 µm)
Pin Surface Plating		Tin (3 - 5 µm), matte
Housing Type		Plastic Case
Mounting Type		PCB Mount
Connection Type		THD (Through-Hole Device)
Footprint Type		DIP8
Soldering Profile		Lead-Free Wave Soldering
		260°C / 10 s max.
Weight		2.7 g
Environmental Compliance	- REACH Declaration	www.tracopower.com/info/reach-declaration.pdf
		REACH SVHC list compliant
		REACH Annex XVII compliant
	- RoHS Declaration	www.tracopower.com/info/rohs-declaration.pdf
		Exemptions: 7(a), 7(c)-I
		(RoHS exemptions refer to the component concentration only, not to the overall concentration in the product (O5A rule).)
	- SCIP Reference Number	2552c69d-e1c1-408c-95ee-5f938293c358

All specifications valid at nominal voltage, resistive full load and +25°C after warm-up time, unless otherwise stated.

Additional Information

Supporting Documents

www.tracopower.com/overview/tdn3wi

Frequently Asked Questions

www.tracopower.com/glossary-faq

Glossary

www.tracopower.com/info/glossary.pdf

Outline Dimensions

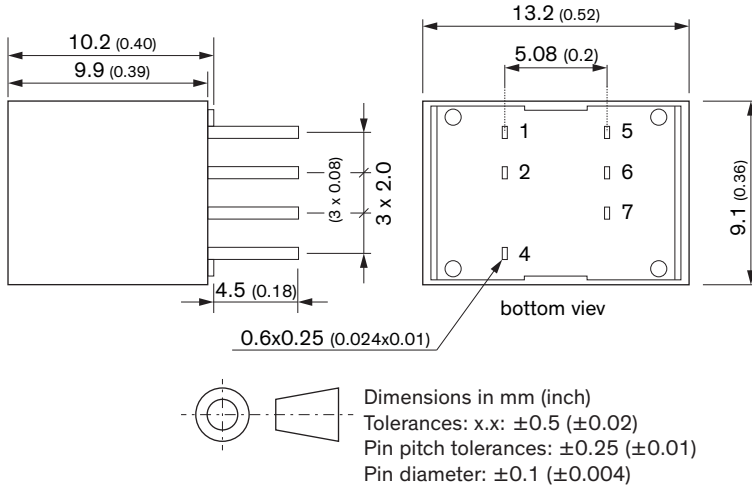

Pinout		
Pin	Single	Dual
1	+Vin (Vcc)	+Vin (Vcc)
2	-Vin (GND)	-Vin (GND)
4	Remote On/Off	Remote On/Off
5	NC	-Vout
6	-Vout	Common
7	+Vout	+Vout

NC: Not connected