



DCS-series



■ Feature

- Ideal for distributed power systems
- Wide output voltage range allows for flexible voltage settings.
- Output voltage can be varied to near 0V
- Constant current regulation
- Parallel Operation / N+1 Parallel Redundancy Operation
- Built-in ORing MOSFET (Option)
- Built-in overcurrent, overvoltage and thermal protection circuits

■ CE marking

- Low Voltage Directive
- RoHS Directive

■ UKCA marking

- Electrical Equipment Safety Regulations
- RoHS Regulations

■ Safety agency approvals

- UL62368-1, C-UL (equivalent to CAN/CSA-C22.2 No.62368-1), EN62368-1

■ 5-year warranty

DCS1400B

DC S 1400 B 28 -□

① ② ③ ④ ⑤ ⑥

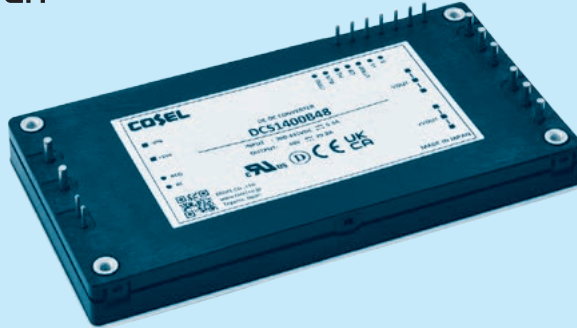

- ① Series name
- ② Single output
- ③ Output wattage
- ④ Input voltage
B : 200 - 435VDC
- ⑤ Output voltage
- ⑥ Optional
T : with Mounting hole
(φ 3.4 thru)
R : with Remote ON/OFF
(Positive logic control)
N1: Auto restart from thermal
protection
P2: Built-in ORING MOSFET

- * If remote on/off is not necessary, connect between RC & RCG.
- * Keep VTRM open, if output voltage adjustment is not necessary.
- * Keep ITRM open, if output current adjustment is not necessary.
- * If remote sensing is not necessary, connect between +Vout & +S and between -Vout & -S.

MODEL	DCS1400B12	DCS1400B24	DCS1400B28	DCS1400B36	DCS1400B48	DCS1400B65
MAX OUTPUT WATTAGE[W]	1200	1404	1400	1404	1401.6	1404
DC OUTPUT	12V 100A	24V 58.5A	28V 50A	36V 39A	48V 29.2A	65V 21.6A

SPECIFICATIONS

	MODEL	DCS1400B12	DCS1400B24	DCS1400B28	DCS1400B36	DCS1400B48	DCS1400B65	
INPUT	VOLTAGE[VDC]	200 - 435 (Surge Voltage 500V, 100ms max)						
	CURRENT[A]	4.61typ	5.34typ	5.29typ	5.28typ	5.27typ	5.28typ	
	EFFICIENCY[%]	93typ	94typ	94.5typ	95typ	95typ	95typ	
OUTPUT	VOLTAGE[V]	12	24	28	36	48	65	
	CURRENT[A]	100	58.5	50	39	29.2	21.6	
	LINE REGULATION[mV]	24max	48max	56max	72max	96max	130max	
	LOAD REGULATION[mV]	24max	48max	56max	72max	96max	130max	
	RIPPLE[mVp-p]	-10 to +100°C *2	120max	120max	120max	150max	200max	350max
		-40 to -10°C *2	160max	160max	160max	200max	250max	400max
	RIPPLE NOISE[mVp-p]	-10 to +100°C *2	150max	150max	150max	200max	250max	400max
		-40 to -10°C *2	180max	180max	180max	240max	300max	450max
	TEMPERATURE REGULATION[mV]	-10 to +80°C	120max	120max	280max	360max	480max	650max
		-40 to +100°C	240max	240max	560max	720max	960max	1300max
	OUTPUT VOLTAGE ADJUSTMENT RANGE *3	Fixed (TRM pin open), 0 - 120% adjustable by external VR or external voltage						
	OUTPUT VOLTAGE SETTING[V]	0 to 14.40	0 to 28.80	0 to 33.60	0 to 43.20	0 to 57.60	0 to 78.00	
		12.00 to 12.12	24.00 to 24.24	28.00 to 28.28	36.00 to 36.36	48.00 to 48.48	65.00 to 65.65	
PROTECTION CIRCUIT AND OTHERS	OVERCURRENT PROTECTION	Works over 105% of rating and recovers automatically						
	OVERVOLTAGE PROTECTION	15.0 to 16.8	30.0 to 33.6	35.0 to 39.2	45.0 to 50.4	60.0 to 67.2	81.3 to 91.0	
	REMOTE SENSING	Provided						
	REMOTE ON/OFF	Provided						
ISOLATION	INPUT-OUTPUT	3,000VAC 1minute, Cutoff current = 10mA, 500VDC 50MΩ min (20 ±15°C)						
	INPUT-FG	2,000VAC 1minute, Cutoff current = 10mA, 500VDC 50MΩ min (20 ±15°C)						
	OUTPUT-FG	DCS1400B12/24/28/36/48 : 500VAC 1minute, Cutoff current = 100mA, 500VDC 50MΩ min (20 ±15°C) DCS1400B65 : 1,200VAC 1minute, Cutoff current = 10mA, 500VDC 50MΩ min (20 ±15°C)						
ENVIRONMENT	OPERATING TEMP., HUMID. AND ALTITUDE	-40 to +100°C (Baseplate temperature), -40 to +85°C (Ambient temperature), 20 - 95%RH (Non condensing), 5,000m (16,500 feet) max						
	STORAGE TEMP., HUMID. AND ALTITUDE	-40 to +100°C, 20 - 95%RH (Non condensing), 9,000m (30,000 feet) max						
	VIBRATION	10 - 55Hz, 49.0m/s ² (2G), 3minutes period, 60minutes each along X, Y and Z axis						
	IMPACT	196.1m/s ² , 11ms, once each X, Y and Z axis						
SAFETY	AGENCY APPROVALS	UL62368-1, C-UL (equivalent to CAN/CSA-C22.2 No.62368-1), EN62368-1						
OTHERS	CASE SIZE/WEIGHT	116.8 × 12.7 × 61.0mm [4.6 × 0.5 × 2.4 inches] (W × H × D) / 230g max						
	COOLING METHOD	Conduction cooling (e.g. heat radiation from the aluminum base plate to the attached heat sink)						

- *1 At rated input(280VDC) and rated load.
- *2 Refer to instruction manual for measuring method of electric characteristics.
- *3 If the output voltage is changed to 60% or less of the rated output voltage, the line regulation, load regulation, ripple, and ripple noise specifications may be violated. In addition, if the output voltage is set to 0V, a residual voltage will occur.

Block diagram

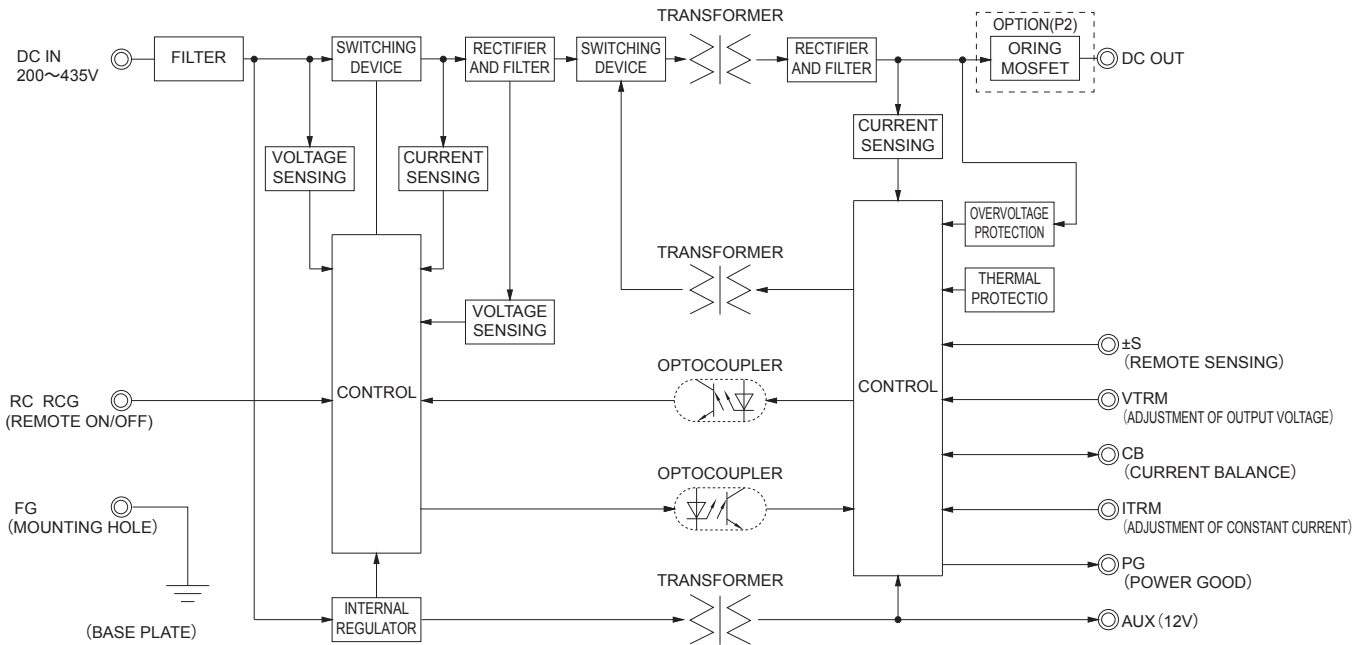

External view

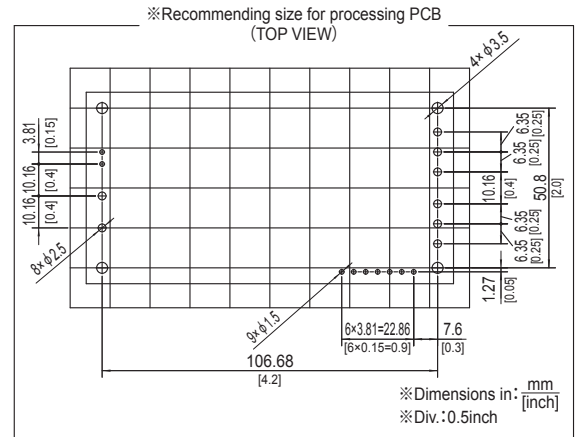
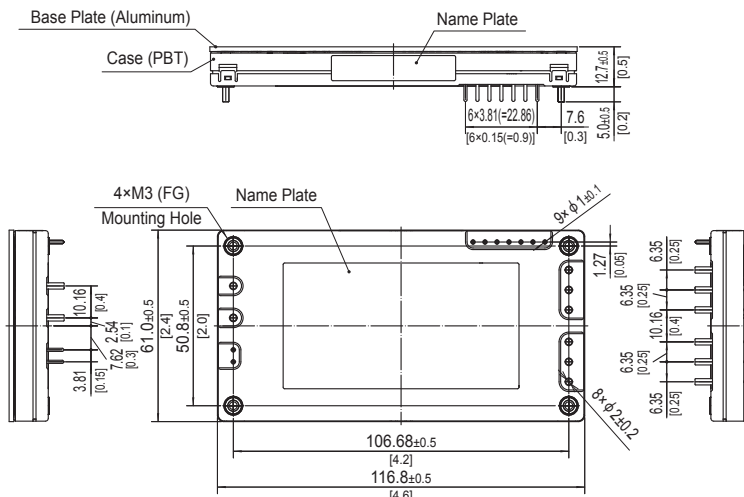

Pin Configuration

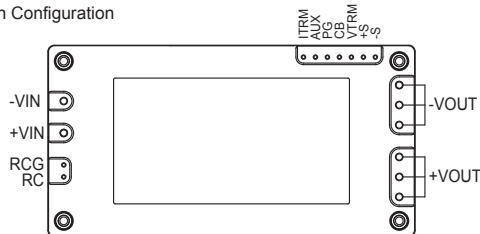

- ※ Dimensions in mm, []=inches
- ※ Tolerance : ±0.3 [±0.012]
- ※ Weight : 230g max
- ※ Pin terminal material : Copper
- ※ Plating treatment of pin : Lead free plating
- ※ Mounting hole screwing torque : 0.49N·m max

Pin Configuration

DCS1400B

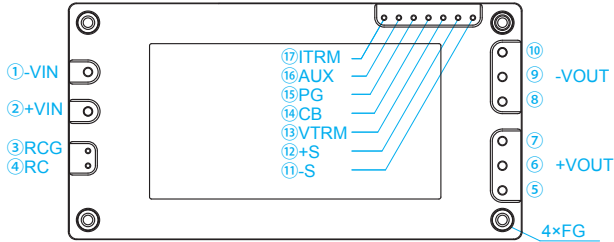

NO.	Pin Connection	Function
①	-VIN	-DC input
②	+VIN	+DC input
③	RCG	Remote ON/OFF (GND)
④	RC	Remote ON/OFF
⑤ ⑥ ⑦	+VOUT	+DC output
⑧ ⑨ ⑩	-VOUT	-DC output
⑪	-S	Remote sensing (-)
⑫	+S	Remote sensing (+)
⑬	VTRM	Adjustment of output voltage
⑭	CB	Current balance
⑮	PG	Power good output
⑯	AUX	Auxiliary output for PG
⑰	ITRM	Adjustment of constant current
—	FG	Mounting hole (FG)

Implementation • Mounting Method

Mounting method

- Use with the conduction cooling (e.g. heat dissipation from the aluminum base plate to the attached heat sink).
- Use a heat sink that larger than the power supply and has a large thickness so that the aluminum base plate can be cooled uniformly.
- The unit can be mounted in any direction. When two or more power supplies are used side by side, position them with proper intervals to allow enough air ventilation. Aluminum base plate temperature of each power supply should not exceed the temperature range shown in “derating”.
- Avoid placing the DC input line pattern layout underneath the unit. It will increase the line conducted noise. Make sure to leave an ample distance between the line pattern layout and the unit. Also avoid placing the DC output line pattern underneath the unit because it may increase the output noise. Lay out the pattern away from the unit.
- Avoid placing the signal line pattern layout underneath the unit because the power supply might become unstable. Lay out the pattern away from the unit.
- High-frequency noise radiates directly from the unit to the atmosphere. Therefore, design the shield pattern on the printed circuit board and connect it to FG. The shield pattern prevents noise radiation.
- When a heat sink cannot be fixed on the base plate side, order the power module with “-T” option. A heat sink can be mounted by affixing a M3 tap on the heat sink. Please make sure a mounting hole will be connected to a grounding capacitor CY.

	Mounting hole
Standard	M3 tapped
Optional : -T	φ 3.4 thru

Stress onto the pins

- When too much stress is applied to the pins may damage internal connections. Avoid applying stress in excess of that shown in right figure.
- The pins are soldered onto the internal PCB. Therefore, Do not bend or pull the leads with excessive force.
- Fix the unit on PCB (fixing fittings) by screws to reduce the stress to the pins. Be sure to mount the unit first, then solder the unit.

DCS1400B

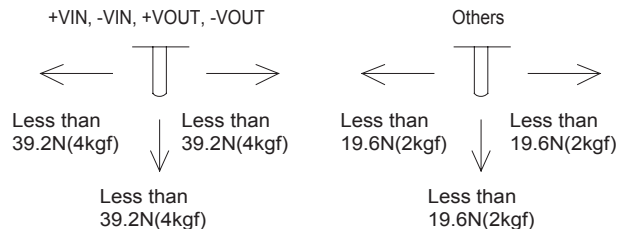

Soldering temperature

- Flow soldering : 260°C for up to 15 seconds.
- Soldering iron (47W) : 450°C for up to 5 seconds.

Derating

Output voltage derating curve

- Use the power modules with conduction cooling (e.g. heat dissipation from the aluminum base plate to the attached heat sink). Below shows the derating curves with respect to the aluminum base plate temperature. Note that operation within the hatched areas will cause a significant level of ripple and ripple noise.
- Please measure the aluminum base plate temperature at measurement point A as shown in the diagram below.
- Please measure the temperature at measurement point B on the aluminum base plate edge side when you cannot measure the aluminum base plate temperature at measurement point A. In this case, please take 5deg temperature margin from the derating characteristics shown in below.
- Please reduce the temperature fluctuation range as much as possible when the up and down of the temperature are frequently generated. Contact us for more information on cooling methods.

DCS1400B

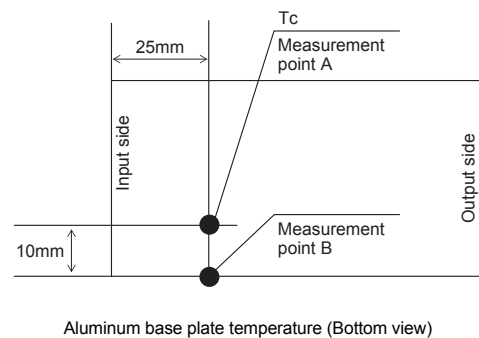
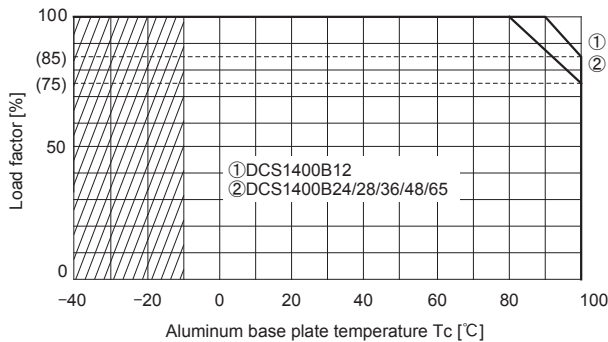

Instruction Manual

- ◆ It is necessary to read the "Instruction Manual" and "Before using our product" before you use our product.

Instruction Manual <https://www.cosel.co.jp/redirect/catalog/en/DCS/>
 Before using our product <https://en.cosel.co.jp/technical/caution/index.html>

DCS



NOTICE



Basic Characteristics Data

Model	Circuit method	Switching frequency [kHz]	Input current [A]	Series/Parallel operation availability	
				Series operation	Parallel operation
DCS1400B	Buck converter	300	5.3 *1	○	○
	Full-bridge converter	150			

*1 The value of input current is at rated input and rated load.